

UCLA

UCLA Electronic Theses and Dissertations

Title

A Phase Approach to Spanish Object Clitics

Permalink

<https://escholarship.org/uc/item/19v6h6cj>

Author

Romain, Ian James

Publication Date

2015

Peer reviewed|Thesis/dissertation

UNIVERSITY OF CALIFORNIA

Los Angeles

A Phase Approach to Spanish Object Clitics

A dissertation submitted in partial satisfaction of the
requirements for the degree Doctor of Philosophy
in Hispanic Languages and Literatures

by

Ian James Romain

2015

© Copyright by

Ian James Romain

2015

ABSTRACT OF THE DISSERTATION

A Phase Approach to Spanish Object Clitics

by

Ian James Romain

Doctor of Philosophy in Hispanic Languages and Literatures

University of California, Los Angeles, 2015

Professor Claudia Parodi-Lewin, Co-chair

Professor Antonio Carlos Quicoli, Co-chair

In light of recent attempts to revive the operation of syntactic head movement and clitic movement in Phase Theory (Roberts 2010a, 2012), we argue that object clitics are underlyingly determiners in the syntax. Clitics engage in probe/goal relations to value and delete their uninterpretable Case features, and upon Agree, cliticize to their host via head-to-head incorporation. Although this account adopts the bare phrase structure theoretic mechanism employed by Ian Roberts to instantiate head movement (i.e., ‘defective goals’), the work outlined here diverges from the details of Roberts’s account, most crucially by positing Abstract Case features on clitics. Based on clitic constructions from Standard Spanish, and various dialects, it will be demonstrated that the behavior of clitics, like that of other nominal elements, is governed by general abstract conditions on movement, namely Relativized Minimality (Rizzi 2013), Case

Theory and the Phase Impenetrability Condition (Chomsky 2001, 2004, 2008). After a careful rethinking of well-known intervention and impenetrability effects (i.e., islands) involving clitics in Spanish, it is claimed that their movement, although unique in being both maximal and minimal, otherwise conforms to the standard conditions imposed on determiner phrases more generally. Contrary to recently influential Base Generation accounts, this work makes a case for distinguishing clitic movement from the movement of doubles, through a detailed study of Exceptional Case-Marking (ECM) constructions, where multiple clitic arguments can raise to object (Chomsky 2013). The complex array of possibilities involving clitic placement in these structures exemplifies the interaction of clitics with Case assignment and distinguishes the minimal nature of clitic head movement from XP movement of doubles. Finally, Chomsky's theory of Inheritance (2008) figures crucially in this account, as it is used to explain the order of clitics in clusters of two and three. Inheritance is also used to explain island effects that block clitic climbing. This study concludes by making the case that while in certain dialects, such as Los Angeles Vernacular Spanish (Parodi 2009a, 2011), clitics have apparently evolved into agreement/object markers, in most dialects, including the Standard, both direct object (DO) and indirect object (IO) clitics are argument pronouns that move to their derived positions in the syntax. Such pronominal clitics are contrasted with truly base-generated 'morpheme' clitics, including 'inherently' reflexive clitics and 'speaker' ethical dative clitics (Strozer 1976), which cannot be doubled or related by the syntax to a corresponding stressed argument. The account that follows then, although firmly within the movement tradition of clitics (Kayne 1975, Quicoli 1976) is intended to complement morphological approaches to clitic clustering with non-argument clitics (Cuervo 2013), and to shed light on the workings of the interface that relates the narrow syntax to the phonological component of the grammar.

The dissertation of Ian James Romain is approved.

Tim Stowell

Maarten van Delden

Claudia Parodi-Lewin, Committee Co-chair

Antonio Carlos Quicoli, Committee Co-chair

University of California, Los Angeles

2015

To my family:

To Mika.

To my father, Michael, and my mother, Liana.

TABLE OF CONTENTS

Acknowledgements	xiii
Vita	xv
1 Introduction	1
1.1 Clitics in Spanish.....	1
1.2 Outline of the Dissertation.....	8
2 Clitics in Generative Grammar and the Basic Spanish Facts	14
2.1 Morphology or Syntax?.....	14
2.2 The Main Contenders: Movement v. Base-Generation.....	20
2.3 Doubling and Interpretive Restrictions on Clitics.....	33
2.4 The Status of Indirect Object Clitics.....	41
2.5 Two Types of Dative Constructions in Spanish.....	42
2.6 Evolution of Accusative and Dative Clitics from Latin.....	57
2.7 Conditions on Clitic Climbing.....	59
2.8 Islands: Barriers to Clitic Climbing.....	71
2.9 The ‘Other’ Clitics of Spanish: Speaker Datives and <i>SE</i> Constructions.....	77
2.10 Concluding Remarks.....	86
3 Dialectal Variation with Spanish Clitics	89
3.1 A Challenge to the Movement Hypothesis?.....	89
3.2 <i>Leísmo</i> and the ‘Parasitic Plurals’ Connection.....	91
3.3 <i>Leísmo real</i> v. <i>Leísmo aparente</i>	97
3.4 <i>Laísmo, Loísmo</i>	104

3.5	<i>Porteño</i>	108
3.6	<i>Andino</i> , Los Angeles Vernacular Spanish (LAVS).....	113
3.7	<i>¡Órale!</i> : Expletive Clitics.....	117
3.8	Clitic Duplicating Varieties <i>en Sudamérica</i>	119
3.9	Concluding Remarks.....	123
4	Phase Theory, Minimality, and Head Movement	126
4.1	Clitics in Phase Theory.....	126
4.2	Phase Theory: A Brief Review.....	127
4.3	Role of Features in Phase Theory.....	130
4.4	Delete or Crash: Uninterpretable Features.....	133
4.5	ECM Constructions in Phase Theory.....	137
4.6	Feature Inheritance.....	141
4.7	Impenetrability and Intervention Effects.....	143
4.8	Relativized Minimality: From Positions to Features.....	146
4.9	Head Movement in Generative Grammar.....	150
4.10	A Phase-Theoretic Implementation of Head Movement.....	156
4.11	Clitic Movement without Case?.....	163
4.12	Concluding Remarks.....	171
5	Clitics by Phase: Move D Heads!	174
5.1	Role of Case: Prefacing the Analysis.....	174
5.2	Basic Clitic Constructions.....	176
5.3	Dative Clitic Constructions.....	179
5.4	Phrasal Movement of Clitics.....	187

5.5	Clitic Climbing.....	194
5.6	Enclisis.....	198
5.7	Clitic Climbing in ECM Constructions: The Case for Case.....	203
5.8	Object Clitics and Minimality Effects.....	212
5.9	The Clitic Left Below: Out-Dative.....	215
5.10	Distinguishing Clitic Movement from that of Doubles.....	218
5.11	When Clitics Block Clitics.....	222
5.12	A Phase Apart: The PIC and Island Effects.....	224
5.13	Binding of Reflexive Clitics by Phase.....	230
5.14	Verb Feature Inventory in Clitic Constructions.....	233
5.15	Concluding Remarks.....	234
6	Conclusions.....	237
	Bibliography.....	240

LIST OF FIGURES

1.1: Base Configuration of Internal Argument Clitics.....	6
1.2: Derived Structure of Clitic Movement.....	7
2.1: The Movement Approach to Object Clitics.....	21
2.2: The Base Generation Approach to Object Clitics.....	24
2.3: Agreement Approach to Base Generation in Doubling Dialects (Suñer 1988).....	26
2.4: Base Generation of Clitics Without Agreement (Luján and Parodi 2001).....	27
2.5: Derivation of Clitic Constructions <i>à la Sportiche</i> (1996, 1999).....	31
2.6: DO Clitic as Head of DP-External Merge Position.....	39
2.7: DO Clitic and Double- External Merge Position in the DP (Uriagereka 1995).....	40
2.8: The Base Configuration of Prepositional Dative Constructions.....	48
2.9: The Base Configuration of Double Object Constructions.....	49
2.10: v-phase Derivation of Arguments in Prepositional Dative Constructions in Spanish (ex. <i>Presentamos a la doctora a su paciente</i>).....	52
2.11: v-phase Derivation of Arguments in Double Object Constructions in Spanish (ex. <i>Le presentamos su paciente a la doctora</i>).....	53
2.12: External Merge Positions of IO and DO Clitics in Double Object Constructions.....	57
2.13: Biclausal Derivation of Clitic Climbing Structures.....	66
2.14: Embedded Verb Inversion in Clitic Climbing in Spanish.....	69
3.1: Three Clitic Cluster- No Tampering with IO-DO Merger.....	96
3.2: Clitic Movement in <i>Porteño</i> Doubling Structures (<i>sans</i> Kayne's Generalization).....	112
4.1: Model of Grammar in Phase Theory.....	127
4.2: Phase Search Space and Complement Domains.....	130
4.3: Valuation and Deletion of Features (ex. <i>Ellos fueron encarcelados</i>).....	136
4.4: ECM <i>in situ</i> (ex. <i>Yo vi al niño besar a su gato</i>).....	138

4.5: Raising to Object in ECM Constructions	139
4.6: Long Verb Movement in Breton.....	159
4.7: Derivation of IO-DO Clusters with the Applicative.....	169
5.1: Direct Object Clitic in Base Configuration.....	176
5.2: Feature Distribution for Single Clitic Agreement.....	177
5.3: Derivation of <i>Yo la veo</i> ('I see her').....	178
5.4: Basic Setup of a Double Object Construction (IO clitic + DO DP).....	180
5.5: Feature Distribution for a Double Object Construction.....	180
5.6: Derivation of <i>Juan le dio el libro</i> ('Juan gave her the book').....	182
5.7: Feature Distribution for a Clitic Cluster.....	182
5.8: Derivation of <i>Juan me lo dio</i> ('Juan gave me it').....	185
5.9: Derivation of <i>Lo he visto</i> ('I have seen it').....	188
5.10: Derivation of <i>Juan me lo ha dicho</i> ('Juan has told me it').....	190
5.11: Derivation of <i>Yo las vi ser atacadas</i> ('I saw them get attacked').....	193
5.12: Feature Distribution for Clitic Climbing.....	194
5.13: Derivation of <i>Ella lo quiere hacer</i> ('She wants to do it').....	196
5.14: Derivation of <i>Ella me las quiere dar</i> ('She wants to give me them').....	197
5.15: Derivation of Enclisis in <i>Ella desea hacerlo</i> ('She wants to do it').....	200
5.16: Derivation of <i>Ella desea intentarlo hacer</i> ('She wants to try to do it').....	202
5.17: Derivation of <i>Yo lo hice escribir la carta</i> ('I made him write the letter').....	205
5.18: Derivation of <i>Yo se la hice lavar</i> ('I made him wash it').....	207
5.19: Failure of Accusative Case Assignment to an IO.....	216
5.20: Full Noun Phrase Banned from Raising to Object with Clitic.....	219
5.21: Derivation of <i>Pedro lo hizo leer a Juan</i> ('Pedro made Juan read it').....	220
5.22: Clitic Over Clitic Movement Banned by Minimality.....	222

5.23: No Clitic Climbing out of a <i>wh</i> -Island.....	225
5.24: No Clitic Climbing out of a <i>Neg</i> -Island.....	228
5.25: Derivation of <i>Juan hizo afeitarse_i a los muchachos_i</i> ('Juan made the boys shave themselves').....	231
5.26: Derivation of <i>?/*Juan se_i hizo afeitarse a los muchachos_i</i> ('Juan made the boys shave themselves').....	232

LIST OF TABLES

1.1: Clitics of Spanish.....	2
2.1: Morphological Similarity between Definite Articles and Direct Object Clitics.....	35
2.2: Evolution of Spanish Clitics from Latin.....	58
2.3: Common Spanish Verbs that Allow Clitic Climbing.....	64
2.4: Common Spanish Verbs that Disallow Clitic Climbing.....	65
2.5: Barriers to Clitic Climbing.....	77
5.1: Features Selected in the Numeration by Verbs in Clitic Constructions.....	233

ACKNOWLEDGEMENTS

First, I want to acknowledge the contributions of my doctoral committee. Carlos Quicoli was my primary mentor throughout the entire PhD process, and he deserves recognition for his tireless and unwavering support. I was very fortunate to receive his steady mentorship and constant willingness to talk about clitics with me. My interest in theoretical syntax, the history of generative grammar, and clitics in particular trace back in large part to the influence of Professor Quicoli. I thank him for his availability, patience, kindness, sense of humor, and positive outlook. I will always fondly remember our time working together on this project.

I also want to thank Claudia Parodi, who helped me tremendously in the development of the present work. Her attention to detail in the areas of Spanish syntax and dialectology were invaluable. I am grateful to Claudia for her inclusive perspective on Spanish, and the fact that she always encouraged me to keep in mind the nuances of vernacular usage, in addition to theoretical concerns. I cannot think of a better mentor to have had in the field of Spanish linguistics.

Furthermore, I want to thank my outside committee member, Tim Stowell. His vast knowledge of all issues related to syntax and the syntax literature was indispensable throughout the dissertation process. Tim was unfailingly helpful, and I thank him for his straightforward and rigorous approach to my work. His comments and insights were always spot-on, and it was a true honor to have him on my committee.

Finally, I want to acknowledge Professor Maarten van Delden. His kindness and perspective from the field of literature was of great help during my exams and ABD defense. I thank him for his useful questions during the defense, and I am grateful that he encouraged me to frame my work on syntax in a more global way, so that it would be more accessible to all

scholars of Spanish, not just linguists. I also thank him for his wonderful seminar on the Mexican novel, the only literature class I took at UCLA, and an enjoyable one at that.

Of my classmates, I would like to thank Bryan Kirschen, Franny Brogan, Jhonni Carr, Armando Guerrero, Mariška Bolyanatz, Belen Villarreal, Covadonga Lamar Prieto, JyEun Son, Michelle Addae, and Polina Vasiliev. What a great group of friends! We shared so many laughs, and it is tough to imagine a better group of colleagues. I thank them for putting up with my sense of humor, and for always being kind.

In particular, I want to acknowledge Chase Raymond, who throughout my time at UCLA exemplified what it means to be a great scholar and friend. As all of his friends and students know, Chase is always there when you need him, and I would be remiss not to acknowledge the many times he gave me great advice.

The one other person at UCLA who I must acknowledge is Juliet-Falce Robinson, who basically taught me everything I know about teaching. Of her many admirable qualities, her professionalism and dedication to students is unmatched. Juliet never gets enough credit for the success of our program, and for the individual success of our teachers, but she deserves to be acknowledged as a great teacher of teachers.

Finally, I acknowledge my family, to whom this work is dedicated. No words can do justice to what my parents and my dearest wife, Mika, mean to me. I look forward to all of the time I can now spend with them upon completing this project. They have been through everything with me, and I owe them all my gratitude and love. Thank you, Mom, Dad, and Mika. Only you three could put up with a son (and husband) like me! This work is for you, and, of course, for Rocco, the best cat in the world, and a great companion through the writing process.

VITA

- 2007 B.A. in Romance Languages and Literatures (*honors*)

 Student Marshal, Phi Beta Kappa

 University of Chicago
- 2008 Curso de Alta Especialización en Filología Hispánica

 Consejo Superior de Investigaciones Científicas (CSIC)

 Madrid, Spain
- 2010 M.A. in Spanish (*Hispanic Linguistics*)

 University of California, Los Angeles
- 2014-2015 PhD Candidate (*Hispanic Linguistics*)

 University of California, Los Angeles
- 2015-2016 Faculty Fellow

 University of California, Los Angeles

CHAPTER 1

Introduction

1.1 Clitics in Spanish

In Modern Spanish¹, as in all the Romance languages, there exist two different types of pronouns. The first type of pronoun, called a clitic pronoun (*clítico* or *pronombre átono* in Spanish), is found attached to verbs. Spanish clitics can attach to the front of verbs, as in example (1), or to the end of verbs, as in example (2):

- (1) La veo.
 her.ACC-FEM I see
 “I see her.”
- (2) Quiero verla.
 I want see.INF her.ACC-FEM
 “I want to see her.”

The second type of pronoun in Spanish is the strong pronoun, also known as the stressed pronoun (*pronombre tónico*). The strong pronoun does not attach to verbs, but rather finds itself in complementary distribution with full noun forms, as shown in bold in the examples in (3):

- (3) a. Lo veo a **él**.
 him.ACC-MASC I see to him

¹ In this work, Modern Spanish will be referred to as simply ‘Spanish,’ *abhinc*.

“I see him.”

b. Veo al **niño**.

I see to the boy

“I see the boy.”

Note that in (3a) the stressed pronoun appears ‘doubled’ by the clitic pronoun *lo* (‘him’). In this sentence, the clitic must be pronounced, while the stressed pronoun, preceded by the differential object marker *a*, is optional (*Nueva gramática de la lengua española* 2009:1244). We can visualize this distinction better through the notation in (4), where the clitic *lo* is obligatory:

- (4) a. *(Lo) veo (a él)²
him.ACC.MASC I see to him
“I see him.”

This work will focus extensively on the complex and subtle array of properties that clitic pronouns exhibit in Spanish. In Table 1.1 we can see the complete inventory of object clitic forms in Spanish, organized by grammatical function.³ Although we will review data associated with non-argument clitics in Spanish in section 2.9 of the present work⁴, the original analysis presented in Chapter 5 primarily focuses on the derivation of internal argument, object clitic pronouns, including those shown in Table 1.1 These specifically include the direct object (‘DO’, ‘accusative’) and indirect object (‘IO’, ‘dative’) clitics:

Table 1.1: Clitics of Spanish

² Key to notation: * α = α is ungrammatical, *(α) = α is obligatory, (α) = α is optional, (* α) = ungrammatical with α included

³ Absent from the Spanish clitic paradigm are the ‘oblique’ clitics, including locatives. Expressions corresponding to French locative/directional *y* include Spanish *allí*, *ahí*, *allá* (‘there’), which are strong, non-clitic pronouns in Spanish (Zagona 2002: 17).

⁴ The non-argument clitics of Spanish include the ‘speaker’ dative clitics (c.f. Strozer 1976) that cannot be doubled by a full noun phrase, as well as the various *SE*-clitic constructions, such as impersonal *se*, passive *se*, aspectual *se*, middle *se*, inchoative *se*, etc. (cf. Mendikoetxea 2012).

Person		1st	2nd	3rd
Direct object clitics 'Accusative'	Singular	me	te	lo _[m] , la _[f] , se _[refl]
	Plural	nos	os	los _[m] , las _[f] , se _[refl]
Indirect object clitics 'Dative'	Singular	me	te	le, se ⁵ _[refl, spur]
	Plural	nos	os	les, se _[refl, spur]

Although there are many studies of clitics to choose from in the generative and Spanish grammar literature, the present study is unique in its rethinking of head movement in an analysis where both direct AND indirect object clitics are underlyingly determiners in the syntax, and as such, obey conditions on movement imposed by minimality and phases. The present work is the first to combine this particular set of powerful theoretical tools in the service of explaining clitic phenomena in a wide array of constructions in Spanish, where it is argued that both accusative and dative clitics move cyclically to attach to verbs in higher clauses. The analysis outlined in Chapter 5 adopts the Phase Theory framework of Chomsky (2000, 2001, 2004, 2008, 2013). We draw particular inspiration from the in-depth study of Romance clitics put forth by Ian Roberts (2010a) within the framework of Phase Theory. Of direct relevance to the approach advocated here, Roberts 2010a revives the operation of head movement for clitics, after many researchers, including Chomsky himself (2001: 37-38), considered dispensing with the head-movement operation altogether, abandoning it to the phonological component of grammar. Chomsky's conjecture that head movement is not part of the narrow syntax has led many researchers to offer proposals eliminating or replacing head movement with other mechanisms, such as PF movement, remnant phrasal movement, and 'reprojective' movement (cf. the references

⁵ Dative *se* is both a reflexive/reciprocal clitic and an allomorph of *le(s)*. This 'spurious' *se* replaces *le* if a third person accusative clitic follows it (e.g., *le +lo = se lo*). In Spanish this opaque form is called *se*, *variante de le* (p.c. Claudia Parodi)

mentioned in Roberts 2011: 195-215). In his recent monograph on the subject of head movement and agreement (2010a), Roberts argues that there is no empirical evidence against narrow syntactic head movement, but actually a great deal of evidence and conceptual arguments in its favor. In the end, he sees no reason for preventing internal merge (i.e. Move) from applying to terminals, such as verbs, clitics, and auxiliary elements.

If Roberts's analysis is on the right track, and we believe it is, then many of the phenomena involving the displacement of clitics can be explained by the fact that minimal elements can move into configurations that are otherwise prohibited to full noun phrases. Head movement, we contend, is indispensable to clitic placement in clitic clusters, clitic climbing constructions, as well as Exceptional Case Marking constructions in Spanish where two clitic arguments can move from the embedded clause to the main clause. This movement is only licit if the arguments in question are terminals—to wit, the maximal expressions that can double and co-occur with clitics induce intervention effects when raising to object in ECM constructions and are thus forbidden in the very same structures that clitics can target readily.

However, the present study differs crucially from Roberts's account in our conviction that clitics are determiners in the syntax. In the approach sketched by Roberts, clitics are considered Caseless elements (i.e. the heads of φ P), whose movement is not subject to freezing or intervention effects. We argue that this conclusion is empirically unjustified and conceptually unsatisfying because of the numerous similarities between clitics and determiners in many Romance languages. Through a careful study of ECM constructions in Spanish, we will demonstrate that the behavior of clitics in Spanish must be attributed to general conditions imposed on these elements by the principle of (Relativized) Minimality and the theories of

abstract Case and Phases. This stance puts us more in line with authors who maintain that direct object clitics are D(eterminer) elements that participate in goal-probe dependencies to value and delete their uninterpretable Case features (c.f., Solà 2002, Boeckx and Gallego 2008). In our analysis, clitic movement is thus constrained by the abstract conditions that are standardly assumed to regulate the behavior of determiner phrases more generally (c.f. Uriagereka 1995, Roca 1996, Raposo and Uriagereka 2005, Ormazabal and Romero 2013).

Furthermore, and unique to the present analysis, we generate indirect object clitics as arguments in addition to direct object clitics and move both successive-cyclically as pronominals. In most of the recent generative literature on the topic of Spanish datives, indirect object clitics are considered morphological affixes generated in verbal/functional heads (Strozer 1976, Demonte 1995, Cuervo 2003, 2010, Ormazabal and Romero 2013). Under these assumptions, dative clitic placement is a strictly morphophonological process, without too much interest for syntacticians. Personally we find the early studies of clitics within generative grammar to be the most promising and inspiring (e.g. Kayne 1975, Quicoli 1976), for reasons to fully spelled out in the analysis in Chapter 5. The present study thus endeavors to harken back to the spirit of those works, in which clitics play a prominent role in the syntactic derivation, and, if on the right track, shed insight into the nature of Agreement, displacement, and the Case filter in the Faculty of Language (FL). Accordingly, we adopt the *movement analysis* of clitics, for both direct object (DO) and indirect object (IO) clitics.⁶ Briefly, this hypothesis predicts that object clitics are, as they appear to be *prima facie*, pronominal elements that originate as the internal arguments of the

⁶ See Section 2.2 for details on important movement and base-generation proposals of clitics.

verbs with which they are semantically associated, as sketched in Figure 1.1⁷, for the sentence in example (5):

- (5) Ella me lo dio.
 she me.DAT it.ACC-MASC gave
 “She gave me it.”

Figure 1.1: Base Configuration of Internal Argument Clitics

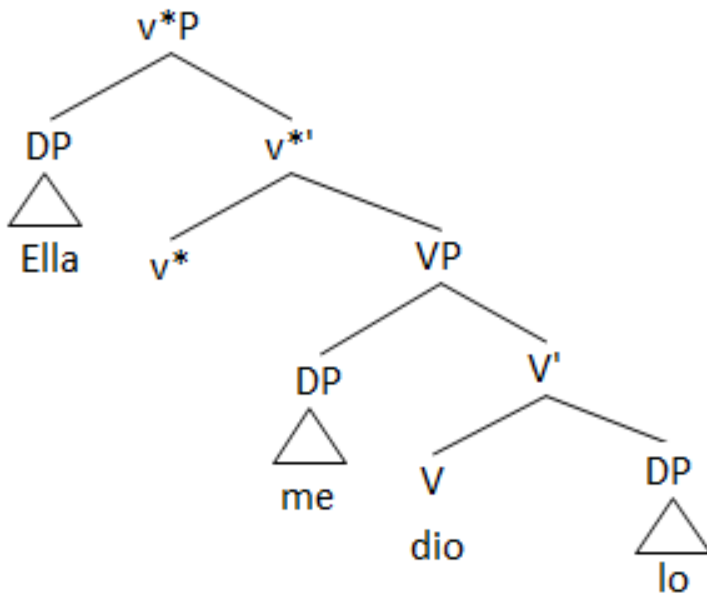
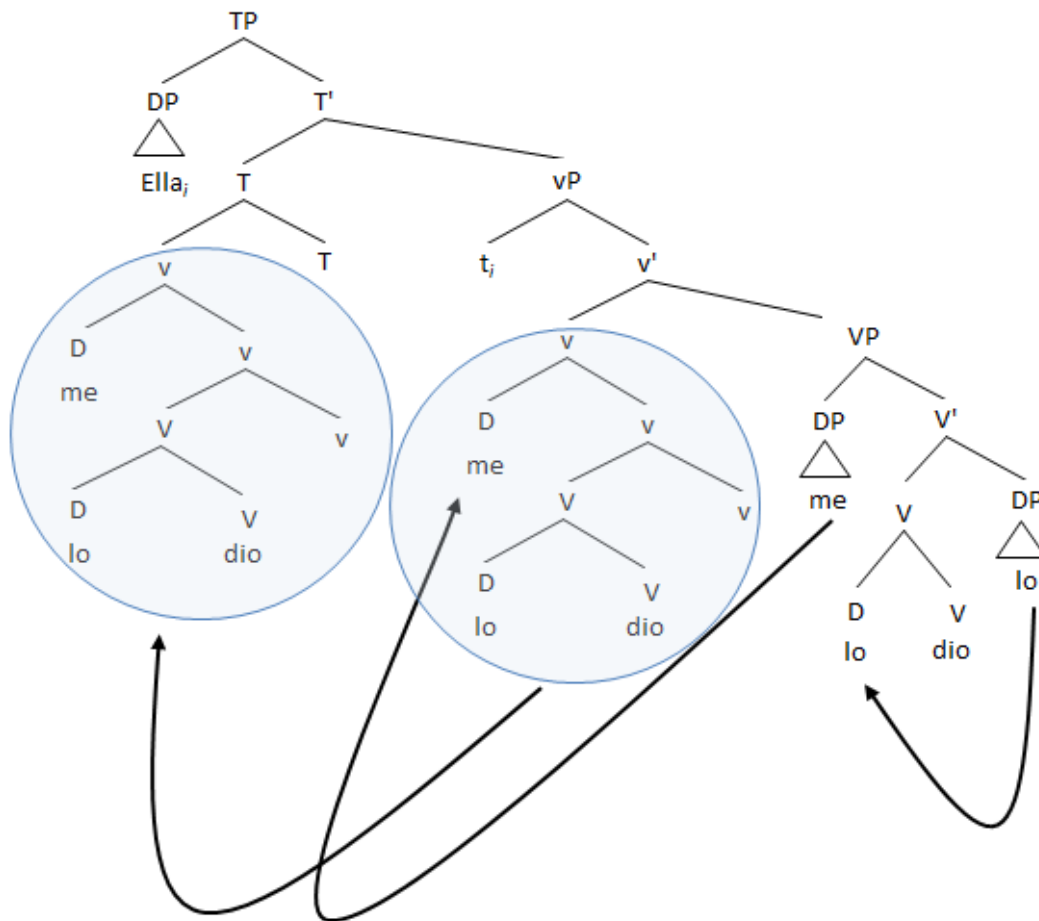

Figure 1.1 is a visualization of the v-phase before the application of syntactic operations (e.g. Move, Agree, etc.). It shows the original, External-Merge positions, a.k.a., theta positions, of the direct object clitic (*lo*) and the indirect object clitic (*me*) for the derivation of the sentence in (5). From their theta positions, where the IO c-commands the DO in Figure 1.1, both clitics will be

⁷ In this work we adopt the basic ‘Larsonian-shell’ configuration of internal arguments for double object constructions. In the derivation of these constructions, the direct object DP is first-merged as the sister of V, while the indirect object DP is externally merged in [Spec, VP]. Empirical evidence in favor of this configuration is presented in Section 2.5.

shown to move to their derived positions via a series of head movements, including head movement of the clitics themselves, as well as movement of the complex heads in V and v. In Figure 1.2 on the next page, we preview the mechanics of the entire derivation of (5):

Figure 1.2: Derived Structure of Clitic Movement



As shown in Figure 1.2 (in the derivation of 5), the direct object clitic *lo* ('it') first adjoins to the verb *dio* ('gave'). Second, the verbal complex [*lo-dio*] adjoins to 'little v' (also known as v* in Chomsky's seminal works on Phase Theory), yielding the complex head [*lo-dio-v*]. Third, the indirect object clitic *me* ('me') adjoins to v* to form the little v complex [*me-lo-dio-v*]. Finally,

the entire little *v* complex adjoins to *T*. The reasoning behind the postulation of these movements is motivated in detail in section 5.3 of the analysis. The key take-away from Figure 1.2 is that clitics engage in probe-goal relations with heads *V* and *v*. These verbal heads value and delete the Case features on clitics, and attract the pronouns to adjoin to them via movement-triggering features called ‘Affix’ features, which originate on verbs and must be deleted in the course of the syntactic derivation to prevent uninterpretable features from reaching Logical Form (LF).

1.2 Outline of the Dissertation

The first chapter of the present work includes the introduction and present outline of the dissertation. In Chapter 2, we will examine the basic distributional properties of direct and indirect object clitics in Standard Spanish. We will also examine closely where clitics can appear in a sentence, and in what ways clitics are similar to and different from stressed pronouns and bound morphemes (e.g., verb agreement affixes). We will show that object clitics are hybrid grammatical elements, combining the morphophonological properties of affixes with the syntactic properties of independent phrases (namely, determiner phrases).

We will then review the phenomenon in which direct and indirect object clitic pronouns appear to be doubled by ‘associate’ determiner phrases (DPs). Clitic doubling has been an extremely active area of theoretical research on clitics, and is central to competing proposals on how to account for these elements. The main theoretical alternatives for the categorial status of clitics will be mentioned in the course of this discussion, and we will argue for one of them, namely the movement hypothesis. In line with Minimalist assumptions, we take movement to be the null hypothesis in explaining apparent instances of displacement in language (cf. Boeckx 2012). The bulk of Chapter 2 is dedicated to upholding this hypothesis, and we find that in the

case of ‘argument’ object clitics in Spanish (i.e. direct and indirect objects), the movement hypothesis is not only intuitively appealing, but empirically supported in the dialects reviewed.

After putting clitics and their doubles through the syntactic and morphological diagnostics that point to their underlying status as arguments, we will explore in depth the semantic properties of accusative and dative clitics, to see with what kind of meanings they can be associated. The analysis of doubling will segue from the semantic scope of accusative and dative clitics to a broader discussion of dative constructions in Spanish. Datives figure crucially in the doubling story, since in Spanish datives can always yield doubled structures. However, we will be careful to distinguish among different types of dative constructions, namely prepositional datives and double object constructions. We also briefly examine the evolution of these elements from Latin, which points to a similar origin and diachronic evolution of DO and IO clitics.

After considering the most plausible base configuration of object clitics in Spanish, we will observe the conditions on movement of clitics across multiple verbs, in the so-called clitic climbing constructions. This will lead to a discussion of popular analyses that attempt to reduce ‘transparency effects’ induced by clitic climbing to the ‘restructuring’ of biclausal configurations into mono-clausal ones (cf. Cinque 2006). The evidence will be examined, and we will conclude that a biclausal analysis is preferable to explain clitic climbing, on empirical and conceptual grounds. Our explanation of clitic climbing will transition into a detailed account of islands, where the presence of certain elements appears to block the movement of clitics from their base positions. Island-inducing elements for Spanish object clitics include lexically specified subjects, negative clausal operators, *wh*-elements, and intervening (abstract Case-bearing) clitics. The final basic facts to be discussed will include a mention of clitics that we assume to be Caseless

(and hence not determiner phrases, but rather verbal morphology). These include a subset of the famous ethical dative clitics of Spanish ('speaker' clitics), as well as the reflexive *se* clitics that cannot project a double (cf. Strozer 1976). At this point, the 'universal' morphological filter on clitic ordering (cf. Perlmutter 1971) will be mentioned with regard to Spanish, as well as some possible dialectal counterexamples to the filter.

Chapter 3 is a review of dialectal variation as it applies to clitic constructions across the Spanish-speaking world. We will start with the well-known variation in the Iberian Peninsula, including *leísmo*, *laísmo*, and *loísmo* of central and northern Spain. We will show how the regional manifestations of these *-ísmos* are essentially morphological variants of the standard dialects that do not alter the underlying syntactic status of object clitics. We conclude that the clitics in these dialects are restricted by the same grammatical principles as those of the standard dialects in the rest of Spain and large parts of Latin America. We also take a moment in this section to contrast the dialectal *leísmo* of modern day Spain with general *leísmo* found throughout the Spanish-speaking world. The latter refers to the fact that in almost all dialects of Spanish, dative and accusative-marked clitics can alternate as the sole object of certain verbs. This pan-Hispanic variation with clitics depends on factors such as the degree of perceived agency of the subject, verbal mood, affectedness in causative constructions, and the reinterpretation of transitive predicates into psychological ones. Also, we will briefly mention pragmatic instances of *leísmo*, known as *leísmo de cortesía* (*leísmo* of courtesy) and *leísmo culto* (*leísmo* as prestigious usage). In addition to *leísmo*, there is a related phenomenon in Northwest Spain where indirect object pronouns are marked accusatively (as in the English double object

construction: ‘I gave her love’). The most common variant of this dialect in Spain is called *laísmo*, and we will see some interesting constructions with this dialect.

After considering *leísmo* and *laísmo/loísmo*, we will look at the well-known dialect of Buenos Aires/ Río de la Plata region, where DO clitics are commonly doubled by non-pronominal DP’s. However, the standard description of this dialect (in which only +specific and +animate direct objects can be doubled) does not actually challenge the current analysis, as such doubling would still obey Kayne’s Generalization (KG) (cf. Kayne 1975). According to KG, in languages that allow doubling, the clitic absorbs Case from the verb, and thus the doubled element must be introduced by a preposition or Case marker (i.e., Case Phrase) (KP). The present analysis relies on the applicability of Kayne’s Generalization, since we consider determiner clitics as arguments that enter the derivation looking to value and delete their abstract Case features. The main dialect of Buenos Aires, ‘*Porteño*’ Spanish, at least in most descriptive accounts, obeys KG, and is thus compatible with a movement analysis of clitics. However, as is well known, Suñer (1988) discovered doubling with inanimate DO’s in spontaneous recordings of certain speakers from this dialect. For those speakers, the DO clitic appears to act as an agreement marker, since the DP double is not introduced via a preposition, and hence must absorb Case from the verb. We concede that for such speakers, the DO clitic may have evolved beyond its pronominal usage, and is a good candidate for a Base Generation analysis. Other such candidates include the DO clitics of dialects spoken in the Andes region of South American, as well as Spanish spoken in Los Angeles and other areas with large populations of Spanish speakers in the United States. The relevant data comes from Luján and Parodi (1991) and Parodi

(2009a, 2011), who make a convincing case for Base Generation. These dialects seem to represent an even further evolution of clitics from agreement to object markers.

The chapter on dialectal variation will conclude with a discussion of dialects in South America, mostly spoken in Chile, where clitics are pronounced in both argument and derived position. These ‘clitic duplication’ varieties appear to support the movement analysis, akin to languages that allow for cases of long-distance questions, in which the *wh*-phrase appears to be repeated in an intermediate position (cf. Boeckx 2008: 28). In terms of our theory, clitic duplication in these dialects is understood as evidence of the Copy Theory of Movement (Nunes 2004). We thus conclude that far from overturning the present analysis, most dialectal variation with clitics in Spanish supports the idea of movement.

Chapter 4 is a review of recent developments in syntactic theory. Here we delve into the details of Phase Theory (cf. Chomsky 2000 *et seq*), as well as the most up-to-date formulation of impenetrability and intervention effects. The latter are explained by Relativized Minimality (cf. Rizzi 1990 *et seq*). In this chapter we also summarize the main arguments of Roberts (2010a), who provides the most recent and exhaustive attempt of that author to incorporate a principled account of Head Movement into Phase Theory. We will carefully review Roberts’s arguments, and show areas of agreement and departure from his account. As we prefaced in the introduction, we will adopt several aspects of Roberts’s account, including his proposed mechanism for instantiating head movement, as well as his featural motivation for head movement. Our main area of contention with his approach has to do with putting Case features on clitics, which we show has major implications and explains many of the intervention effects with clitics observed in the history of generative grammar, dating back to Kayne and Quicoli.

In Chapter 5, we make our case for Case on clitics, through a careful study of configurations with clitics which undoubtedly involve Case theory. In this chapter we also provide the technical details of our own analysis. We derive all of the relevant clitic constructions, and demonstrate how our account nicely interacts with the Phase Impenetrability Condition and Relativized Minimality to yield licit and illicit examples of clitic climbing. We then look closely at exceptional case marking (ECM) and causative constructions involving clitic movement in Spanish. The intricate set of facts reviewed here lends heavy empirical support to our Case approach to clitics, as well as the idea of cliticization being head-to-head incorporation.

In Chapter 6, we offer conclusions. Here we ponder the future of research on head movement, as well as determiner clitics, as we feel both get a new lease on life within the generative research program, assuming the adoption of our arguments.

CHAPTER 2

Clitics in Generative Grammar and the Basic Spanish Facts

2.1 Morphology or Syntax?

As we set out toward our ultimate goal of contributing to the understanding of clitics in a theory of grammar, we should first look at the basic properties that distinguish them from other types of nouns and pronouns. As the Spanish term *pronombre átono* (‘unstressed pronoun’) implies, the clitic does not bear stress, and that is why it must always appear attached to a stressed constituent, such as a verb. When a clitic finds itself attached to the front of a verb, it is known as a proclitic, and when attached to the end of the verb it is called an enclitic. In Spanish, clitics follow affirmative imperatives, infinitives, and gerunds, respectively in (1):

- (1) a. Hazlo ahora.
do.IMP it.ACC.MASC now
“Do it now!”
- b. Ella intentó mandármelo.
she tried send.INF me.DAT it.ACC.MASC
“She tried to send me it.”
- c. Ella estaba cantándolo.

she was singing it._{ACC.MASC}

“She was singing it.”

In Spanish, unlike in fellow Romance language Portuguese, a finite verb form may not be accompanied by an enclitic. Stressed pronouns, on the other hand, may always appear before or after a finite verb, as in (2):

(2) a. *Yo veo la.

I see her._{ACC.FEM}

“I see her.”

b. A ella yo la veo.

to her I her._{ACC.FEM} see

“I see her.”

c. Yo la veo a ella.

I her._{ACC.FEM} see to her

“I see her.”

Other criteria that distinguish clitic pronouns from strong pronouns include coordination, emphasis, modification, and isolation (Kayne 1975, Ordóñez 2012: 424-425). Clitic pronouns, unlike strong pronouns, cannot be coordinated:

(3) *Yo la y lo vi.

I her._{ACC.FEM} and him._{ACC.MASC} I saw

“I saw him and her.”

(4) Los vi a él y a ella.

them._{ACC.PLUR.MASC} I saw to him and to her

“I saw him and her.”

Clitic pronouns cannot be emphasized or focalized, while strong pronouns can:

- (5) a. * Yo LA vi el otro día.

I HER._{ACC.FEM} saw the other day

“I saw HER the other day.”

- (6) Pepe habla de ELLA.

Pepe talks of HER.

“Pepe is talking about HER.”

Clitics cannot be modified, unlike strong pronouns:

- (7) *Los juntos vi en el jardín.

them._{ACC.PLUR.MASC} together._{PLUR.MASC} I saw in the garden

“I saw them together in the garden.”

- (8) Los vi a ellos juntos en el jardín.

them._{ACC.PLUR.MASC} I saw to them together in the garden

“I saw them together in the garden.”

And only strong pronouns, and not clitics, can appear in isolation as an answer to a question:

- (9) ¿A quién viste?

to who(m) did you see

“Who(m) did you see?”

- a. *La.

her._{ACC.FEM}

“Her.”

b. A ella.

to her

“Her.”

The distinguishing properties observed in (2)-(9) might seem to suggest that Spanish clitics and strong pronouns need different syntactic treatments. In some respects, clitics behave like bound morphemes (affixes). Like clitics, bound morphemes cannot be coordinated, as in the example in (10) with prefixes¹:

(10) *No hay que **des** y **rehacer** este trabajo.

no have that un-- and redo._{INF} this job

“No one needs to un—and redo this job”

Also like clitics, bound morphemes cannot appear in isolation, be they prefixes, as in (11a), or verbal agreement suffices, as in (11b):

(11) a. --¿Te gusta hacer la cama o deshacerla?

you._{CL} like make._{INF} the bed or unmake._{INF} it._{ACC-FEM}

“Do you like to make the bed or unmake it?”

--*Des.

un

“Un--”

b. --¿Vamos o vais?

we go or you go

¹ Not all prefixes are resistant to coordination. The English prefix ‘pre—’, for example, can be coordinated in sentences like: ‘In syntax there are pre—and post-cyclical rules.’ Thanks to Tim Stowell (p.c.) for this observation. This is observed with Spanish ‘pre—’ as well, as in this example found on the internet: *La duración del pre y postnatal puede verse alterado (sic)*. (“The duration of pre—and post-natal can be found altered”). <http://www.dt.gob.cl/consultas/1613/w3-article-60107.html>

“Do we go or do you go?

--*Mos.

we

“We.”

However, clitics differ from bound morphemes in crucial ways. First, as we have already noted, unlike affixes, clitics do not adhere to rigid positions inside the word they attach to. They move freely to different positions within a sentence:

(12) a. Quiero verla.

I want see._{INF} her._{ACC.FEM}

“I want to see her.”

b. La quiero ver.

her._{ACC.FEM} I want see._{INF}

“I want to see her.”

If we add more intermediate verbs, it becomes apparent that clitics are not limited to only two positions in the clause, but rather can ‘climb’ from verb to verb:

(13) a. Quiero poder hacerlo.

I want able._{INF} do._{INF} it._{ACC.MASC}

“I want to be able to do it.”

b. Quiero poderlo hacer.

I want able._{INF} it._{ACC.MASC} do._{INF}

“I want to be able to do it.”

c. Lo quiero poder hacer.

it._{ACC.MASC} I want able._{INF} do._{INF}

“I want to be able to do it.”

Also, while agreement morphemes on verbs can alter the natural stress of the form that they attach to, clitics do not affect the placement of stress. Note the contrast between verbal agreement suffix morphemes (*--va*, *--vamos*) in (14) and clitics (*lo*, *me*) in (15)²:

(14) a. Ella *lá*va.

she washes

“She washes.”

b. Nosotros *lavá*mos.

we wash

“We wash.”

(15) *Lá*va.

wash._{IMP}

“Wash.”

b. *Lá*valo.

wash._{IMP} it._{ACC.MASC}

“Wash it.”

c. *Lá*vamelo.

wash._{IMP} me._{DAT} it._{ACC.MASC}

“Wash it for me.”

² Written accents in these examples indicate phonetic stress.

And when both clitics and agreement morphemes are on the same word, only the agreement elements alter the stress, as in (16b):

- (16) a. *Hága.*
do._{IMP}
“Do.”
- b. *Hagámos.*
we do._{IMP}
“Let’s do.”
- c. *Hagámoslo.*
we do._{IMP} it._{ACC-MASC}
“Let’s do it.”
- d. *Hagámonoslo.*
we do._{IMP} us._{REFL} it._{ACC-MASC}
“Let’s do it to each other.”

Hence clitics seem to differ in crucial ways from agreement affixes in their attachment properties, even though they must both attach to a stress-bearing host to be licensed at the level of Phonological Form (PF). The morphological, PF-based rules that regulate cliticization seem to be treating the items differently, which would be unexpected under theoretical approaches to clitics that treat them as inflectional morphemes generated on verbs, to be reviewed below.

2.2 The Main Contenders: Movement v. Base-Generation

As a first approximation then, we suggest that clitics, which can be found in a variety of positions within the clause, are syntactically akin to nouns, but with morphological properties

In Fig. 2.1 above, which we can take as a representative example of movement approaches within the current framework of grammar (e.g. Boeckx and Gallego 2008, Roberts 2010a), the clitic *la* starts as the thematic direct object of the verb *ver* ('see'). From its base position, the clitic moves as syntactic head to attach to the light verb, v^* , a.k.a., little *v*, which is the locus of abstract verb-object Agreement in Phase Theory.³ From little *v*, the clitic moves to the inflectional area of the clause (e.g., T), where it surfaces proclitically in the example in (6).

Current movement approaches to clitics such as those cited immediately above share in common the idea that clitics agree with the functional head little *v* in phi-features, and that this abstract Agreement is related to the movement of the clitic from its thematic position to the accusative Case position of little *v*. From its Case position, the object clitic moves to the inflectional region of the clause, possibly via 'roll-up' with the verbal complex, as in Fig. 2.1.

If movement approaches such as those sketched in Fig. 2.1 are on the right track, then we might expect to find clitics in complementary distribution with the stressed noun forms (i.e., doubles) with which they are associated. This is indeed the case for accusative clitics in Spanish, which do not co-occur with their full noun phrase doubles:

- (17) a. Lo conozco.
 him._{ACC-MASC} I know
 "I know him"
- b. (*Lo) conozco al profesor.⁴
 him._{ACC-MASC} I know to the professor.

³ For the relevant details on Phase Theory and the technical mechanisms/assumptions entailed by this theory, see Chapter 4.

⁴ The inclusion of the clitic in (17a) is not ungrammatical in all dialects of Spanish. For instance, clitic doubling of the type starred in (17a) is acceptable in the *Porteño* dialect spoken in the Buenos Aires region of Argentina (cf. Suñer 1988).

“I know the professor.”

However, as we saw in example (2c) of this chapter, direct object clitics can be doubled by their stressed pronominal forms, reproduced below in (18):

- (18) Yo *(la) veo (a ella).
I her._{ACC-FEM} see to her
“I see her.”

Furthermore, in Spanish, dative clitics can also co-occur with doubles, including non-pronominal doubles, such as in (19):

- (19) Yo le doy el libro a María.
I her._{DAT} give the book to María
“I give the book to María.”

For many dative expressions in Spanish, as with most accusative constructions in the standard dialects of Spanish, the clitic is the mandatory element in doubling structures, such as in the example in (20) with a ‘dative of interest’⁵:

- (20) Lola *(le) comió la manzana a Pepe.
Lola him._{DAT} ate the apple to Pepe
“Lola ate the apple on/for Pepe.”

We can see that this doubling is not mandatory, as in the equally grammatical (21), without the full dative noun associate corresponding to *le*:

- (21) Lola *(le) comió la manzana Ø

⁵ See Strozer (1976: 137-145) for a detailed discussion of ditransitive constructions in Spanish that do not take the dative clitic. These involve indirect objects selected by verbs of transfer, embedded in prepositional phrases. We review the relevant data and arguments in section 2.5, but briefly, the clitic-less constructions are found to correspond to prepositional datives, while the sentences that take the dative clitic in Spanish are underlyingly double object constructions (cf. Larson 1988, Demonte 1995). The types of dative expression that mandatorily subcategorize the IO clitic will also be specified in section 2.5.

Lola him._{DAT} ate the apple

“Lola ate the apple on/for him.”

As the doubled DP in (18) and (21) is optional, while the corresponding clitic is mandatory, researchers in the movement tradition think of full noun doubles as a species of nominal adjuncts. Meanwhile, the clitic in movement hypotheses is the core object argument that absorbs object Case from the verb. However, other researchers regarded doubling as incompatible with movement accounts. Consequently, clitic doubling was largely responsible for an influential contending hypothesis regarding clitics, that of *Base Generation* (cf. Strozer 1976, Rivas (1977), Borer 1984, Suñer 1988, Sportiche 1996, Emonds 1999, Cuervo 2003, 2010, among others).

According to base generation accounts, object clitics are verbal agreement markers attached to inflectional heads in the syntax, while their full noun phrase doubles are the actual nominal expressions generated in argument position, as sketched in Figure 2.2, for (18):

Figure 2.2: The Base Generation Approach to Object Clitics

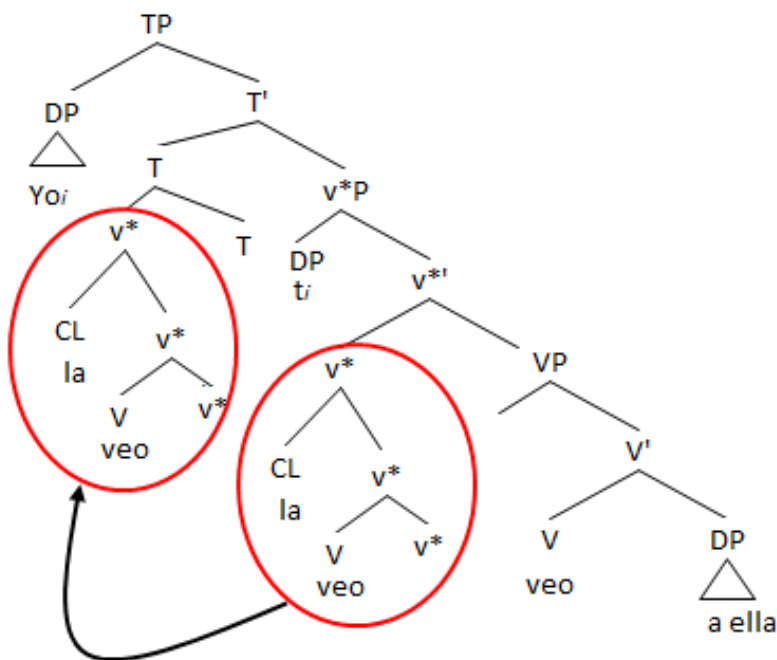

In Fig. 2.2, a rendering of what base generation of a DO clitic would look like in the current framework of generative grammar (cf. Chomsky 2001, 2004, 2008, 2013),⁶ the underlined DO clitic *la* is generated directly within the functional part of the verb (e.g., v^*). In Phase Theory, v^* enters the derivation with object Agreement features (see Sec. 4.3). From v^* , the clitic moves to T as part of v^* -T movement, while the doubled expression stays below in its thematic position.

Solid evidence for base generation accounts of clitics in Spanish, to be considered in depth in Chapter 3, comes from dialects in which speakers can double DO clitics without licensing the double via the special Case morpheme *a*. This occurs among certain speakers of Spanish spoken in the Buenos Aires area, whose dialect is known as Río de la Plata or *Porteño* Spanish. It is possible in this dialect to double DO clitics without licensing the full noun phrase double via the special Case morpheme *a*, as in the contrast in (22):

- (22) a. Yo lo voy a comprar el diario justo antes de subir. (Porteño Spanish)

I it._{ACC·MASC} I am to buy the newspaper just before of come up

“I am going to buy the newspaper just before coming up.”

(Suñer 1988: 399-400)

- b. Yo lo voy a comprar (*el diario) justo antes de subir. (Standard Spanish)

I it._{ACC·MASC} I am to buy the newspaper just before of come up

“I am going to buy the newspaper just before coming up.”

⁶ It should be noted that the last influential base generation account for direct object clitics in Spanish (e.g. Luján and Parodi 2001) was formulated at a time before agreement projections (e.g. AgrSP, AgrOP) were subsumed under other functional heads (e.g. T, v^* respectively) in later Minimalist analyses (cf. the review of the literature and arguments in Hornstein et al., 2005). Therefore, it is not easy to speculate how the mechanics of base generation would work under the most recent assumptions about the clausal architecture, but we consider Figure 2.2. to be on the right track.

According to Suñer (1988), the possibility of doubling in (22a) suggests that clitics function as morphological affixes base-generated as object agreement markers on the verb. For clitic doubling to obtain in this dialect, the clitic and its double must agree fully in terms of grammatical phi-features (e.g. number, person, gender), and must be +specific in interpretation, for reasons to be explained in the next section on clitic doubling, sec. 2.3. Hence, in Suñer’s account (1988), abstract Agreement between the verb and the object is instantiated morphologically via the insertion of the clitic on the verb. This is depicted in Figure 2.3, for the sentence from *Porteño* Spanish in example (23):

- (23) Yo lo leo el periódico. (Porteño Spanish)
 I it.ACC-MASC read the newspaper
 “I read the newspaper.”

Figure 2.3: Agreement Approach to Base Generation in Doubling Dialects (Suñer 1988)

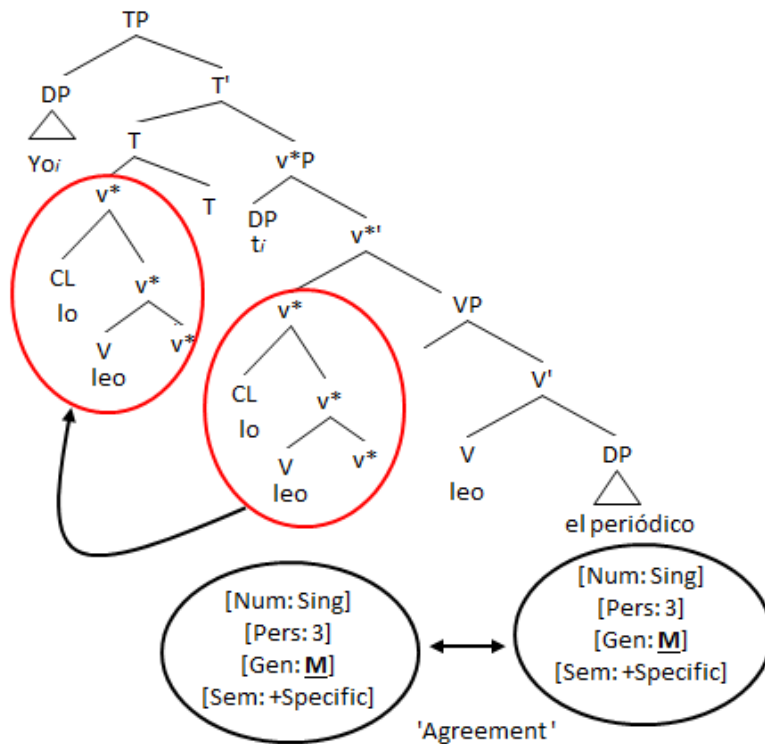

An even stronger dialectal case for the base-generation of clitics can be made in dialects of Spanish spoken in the Andes region of South America (i.e., ‘*Andino*’ Spanish) (Luján and Parodi 2001), as well as Spanish spoken in Los Angeles (i.e., ‘Los Angeles Vernacular Spanish’) (Parodi 2009a). Observe the sentences from Los Angeles Vernacular Spanish in (24 a and b) and in *Andino* Spanish in (24c):

(24) a. Lo_i veo la niña_i. (Los Angeles Vernacular Spanish)

it._{ACC.MASC} I see the girl._{FEM}

“I see the girl.”

b. La_i dejó el coche_i en la esquina. (Los Angeles Vernacular Spanish)

it._{ACC.FEM} pro left the car._{MASC} in the corner

“S/he left the car on the corner.”

c. No lo_i vi a sus hermanitos_i. (*Andino* Spanish)

No it._{ACC.SING.MASC} I saw to his/her brothers._{PLUR}

“I didn’t see his brothers.”

(Luján and Parodi 2001: 193)

In the examples in (24), DO clitics can be doubled without an *a*-phrase, and need not even agree with their doubles in the relevant phi-features, including gender mismatch in (24a) and (24b) and number mismatch in (24c). According to Parodi and Luján, the clitics in these dialects appear as morphological affixes that function as verbal object markers without agreement, as we can see in Figure 2.4, for the example in (24a) from Los Angeles Vernacular Spanish:

Figure 2.4: Base Generation of Clitics without Agreement (Luján and Parodi 2001)

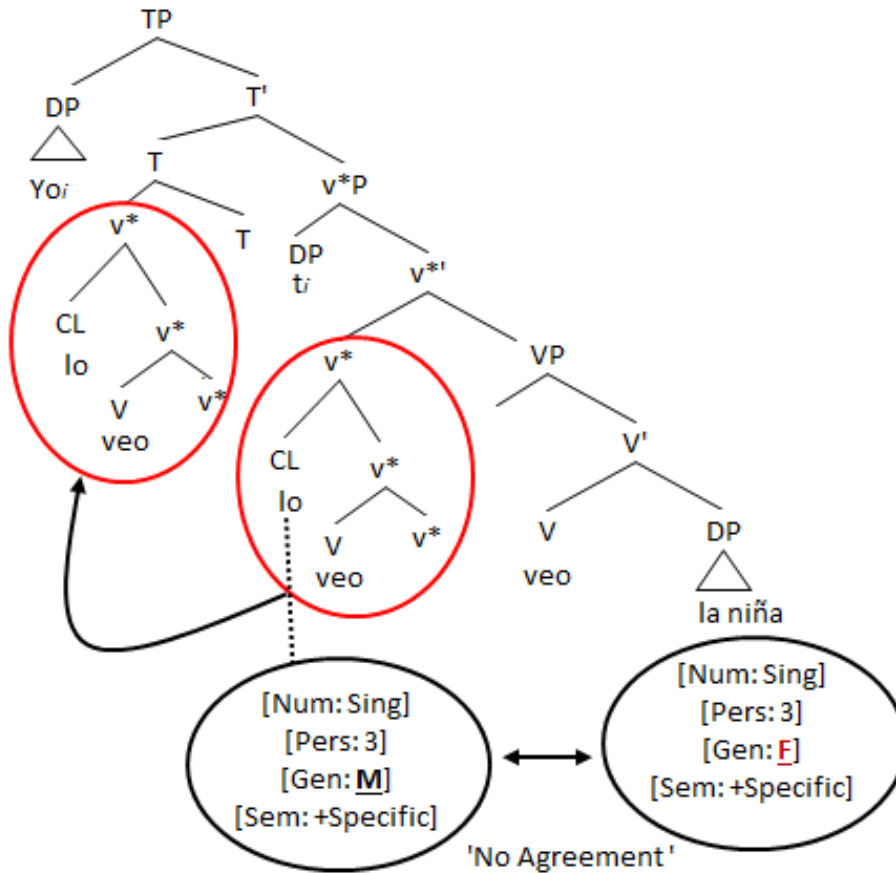

As there is a gender mismatch between the masculine clitic *lo* and its feminine double *la niña* ('the girl'), the clitic in *Andino* and Los Angeles dialects is a morpheme base-generated on the verb in v^* to indicate the presence of a direct object in the propositional region of the clause.⁷

Returning to general thrust of hypotheses of base generation unrelated to specific dialects of Spanish, another crucial aspect that distinguishes these approaches from movement accounts

⁷ We wish to note here that the analysis in Chapter 5 of the present work does not focus on the non-standard dialects exemplified in Figures 2.3 and 2.4. We are primarily concerned with dialects where clitics can most plausibly be argued to be nouns that absorb Case from verbs, and whose doubles, accordingly, receive Case from a preposition or Case Phrase (KP).

“Did you buy potatoes/beer? Yes, I bought them so you could have them at home.”

b. ¿Tienes café? Aquí no encuentro Ø.

you have coffee? Here no I find Ø

“Do you have any coffee? Here I don’t find any.”

c. ¿Tenéis algo de café? Lo siento, no tenemos Ø.

you all have something of coffee? it I feel, no we have Ø

“Do you guys have a little bit of coffee? I’m sorry, we don’t have any.”

d. ¿Has visto muchos elefantes en Kenia? Apenas Ø hemos visto.

Have you seen many elephants in Kenya? Barely Ø we have seen

“Have you seen many elephants in Kenya? We’ve barely seen any.”

e. ¿Compraste algún regalo? Sí compré Ø, aunque con poca convicción.

you buy some gift? Yes we bought Ø, although con little conviction

“Do you buy some gift? Yes, we bought one, but with little conviction.”

(Fernández-Ordóñez 1999: 66)

As we will observe in the next section on clitic doubling, section 2.3 of the present chapter, direct objects with specific or generic interpretation require the presence of object morphology, in the form of the full noun phrase or the accusative-marked clitic. The base generation postulation of an empty object category *pro* for Spanish is nevertheless empirically motivated by the total absence of object morphology in the examples in (27).

Among the more innovative base generation analyses is Sportiche (1996, 1999), who relates the double to the clitic through movement of the double (either overtly or covertly) to the specifier of the functional clitic head [Spec, CliticP (CIP), (a.k.a. DefP, AccP)]. This movement

establishes an agreement dependency between the clitic and the double, and must occur by the syntactic level of Logical Form (LF). Sportiche’s analysis is a ‘mixed’ approach in that it attempts to reconcile differences between base generation and movement hypotheses. We can visualize his approach in the derivation in Figure 2.5 for the Spanish sentence in (25):

Figure 2.5: The Derivation of Clitic Constructions à la Sportiche (1996, 1999)⁸

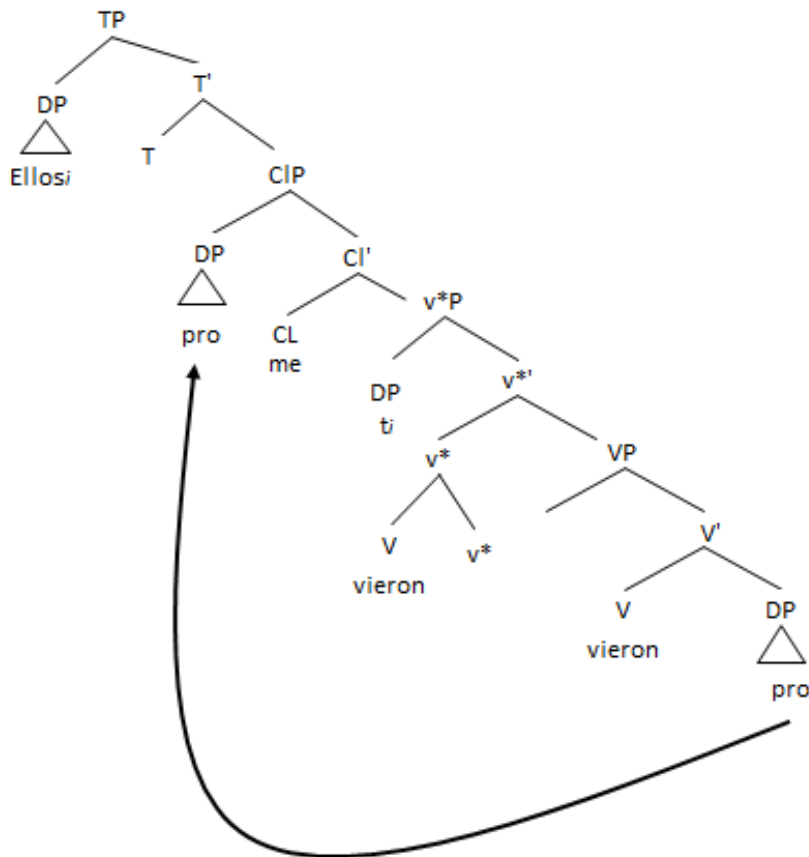

In Fig. 2.5, the null object *pro* moves from the thematic DO position in the complement of V to the inflectional region of the clause, into the specifier position of Sportiche’s Clitic Projection (CIP). The clitic is base-generated in the head of CIP, which c-commands the propositional

⁸ Thanks to Victoria Mateu (p.c.) for her help with this diagram, a modified version of her Sportichean tree in Mateu (2014: 4). In Fig. 2.5 we have had to omit the step of v-T movement, in order to accommodate the categories enumerated by Sportiche (1995). This omission is of course problematic for syntactic accounts of v-T movement, but could be accommodated by accounts that consider verb movement to T to be a phonological, post-syntactic operation (cf. Chomsky 2001). In our analysis in Chapter 5, we opt for syntactic accounts of v-T movement, in line with the reasoning of Roberts (2010a), that v-T is syntactic head movement.

content of the clause (i.e., the v-phase). The movement of the null DO DP into [Spec, CI] establishes a local [Spec, Head] agreement dependency between the clitic and *pro*, its double. The Sportiche approach to clitic constructions is appealing in the sense that it represents a ‘mixed approach’ to clitics, one that attempts to reconcile the displacement and intervention effects related to clitic placement that suggest movement (see section 2.7 for conditions on clitic climbing), as well as the co-occurrence of the double and the clitic that suggest base generation.

Most recently, a third, different ‘mixed’ approach has taken shape that assumes that Spanish clitics are NOT a uniform class (cf. Roca 1996, Bleam 2000, Ormazabal and Romero 2013, among others). Specifically, this last group of authors asserts that direct object (DO) clitics are definite articles (determiners) that head their own projection in the syntax, and receive structural Case as the complement to V.⁹ With regard to DO clitics then, the Mixed Hypothesis advocates postulate movement. Indirect object (IO) clitics, on the other hand, are treated by these authors as morphological affixes generated not in argument position, but rather in a functional verbal head, possibly little *v* or, an Applicative Phrase (cf. Cuervo 2003).¹⁰

Despite the recent popularity of base generation approaches to object clitics, there are nevertheless good reasons in the standard, non-doubling dialects of Spanish, to maintain the movement position that object clitics are in fact nominal elements and not morphological agreement affixes on verbs. These include the following:

(1) Clitics are the mandatorily present element in clitic doubling structures in standard dialects,

⁹ See section 2.3 for the specific arguments relating direct object clitics to definite articles (i.e., ‘determiners’).

¹⁰ See Cuervo 2003 (68-100) for her intricate proposals regarding the Applicative and its use in the derivation of dative expressions in Spanish. In the present work we will stick to the basic Larsonian approach to datives, again outlined in section 2.5 of the present work. Also see Chapter 4 for a movement approach to dative clitics that uses the Applicative (e.g., Roberts 2010a).

- (2) Phonetically null object expressions in Spanish cannot feature a clitic,
- (3) Clitics can target multiple attachment sites in a clause, including verb forms with which they are not thematically associated, in all dialects of Spanish,¹¹
- (4) Clitics do not interact with stress rules in the same way as person verb-morphemes in all dialects of Spanish,
- (5) Noun phrase doubles must be introduced via a preposition, or Case-marking morpheme, *a* ('to') in standard dialects, suggesting that the clitic is the argument that receives Case from the verb, thereby forcing the insertion of the Case morpheme to independently license the double.

To further build the case for the adoption of the movement hypothesis for both object clitics in standard dialects, let us review the doubling facts as they pertain to Spanish. The doubling data are suggestive of the syntactic category to which object clitics belong in the modern generative framework, determiner phrases (DPs).

2.3 Doubling and Interpretive Restrictions on Clitics

We will begin our study of doubling by first looking at the doubling capabilities of direct object clitics in Spanish. Although accusative clitics are in complementary distribution with their doubles within the same intonational contour, the associate DP can appear in a focalized position, in so-called 'Clitic Left Dislocation' (CLLD) constructions. Take (28) as an example:

- (28) La casa todavía no *(la) he visto.
the house yet no it._{ACC.FEM} I have seen
"The house, I haven't seen it yet."

¹¹ See section 2.7 for a detailed discussion of the facts related to clitic climbing in Spanish.

Of course, as we already know, DO clitics can also occur doubled by a strong pronoun in the same intonational contour, as in (29):

- (29) *(Lo) veo a él.
 him.ACC·MASC I see to him
 “I see him.”

And finally, direct object clitics can appear doubled by the universal quantifier *todos* (‘all’), in a configuration that calls to mind the stranded quantifier analysis of Sportiche (1988):

- (30) Ayer (los) vimos todos.
 yesterday (them.ACC·PLUR·MASC) we saw all.PLUR·MASC
 “Yesterday we saw them all.”

As Romero and Ormazabal (2013: 306) observe, the distributional properties of *todos* strongly support the claim that the DO clitic is a determiner. First, the universal quantifier in Spanish is the only one that selects a complement headed by the definite determiner, one that heads a construction of the type in (31), with an example in (32):

- (31) [Quantifier [Det NP]]
- (32) a. Vimos todos *(los) libros
 we saw all the books
 “We saw all the books.
- b. Vimos algunos/bastantes/suficientes/muchos (*los) libros
 we saw some/quite a few/enough/ a lot the books
 “We saw some/quite a few/enough/many (*the) books”

The data above correlate with the fact that the universal quantifier is the only one that doubles:

- (33) a. (Los) vimos todos.
 them.ACC-PLUR-MASC we saw all
 “We saw all of them”
- b. (*Los) vimos algunos/bastantes/suficientes/muchos
 them.ACC-PLUR-MASC we saw some/quite a few/sufficient/many
 “We saw some/quite a few/enough/ a lot.”
- (Suñer 1988: 410-411)

Another similarity between clitics and determiners is that both 3rd person DO clitics and definite articles share the same morphological shape (with the exception of the singular masculine clitic):

Table 2.1: Morphological Similarity between Definite Articles and Direct Object Clitics

	Masculine		Feminine		Neuter
	Singular	Plural	Singular	Plural	
Determiner	el	los	la	las	lo
Clitic	lo	los	la	las	lo

Furthermore, as Suñer (1988) and Roca (1996) convincingly argue, the meanings associated with the accusative clitic strongly mirror those of the definite article in Spanish. It has been standardly assumed since Suñer (1988) that the accusative clitic acts as a kind of specificity marker, in that it refers to specific DPs. Thus, the accusative clitic cannot be associated with non-specific noun phrases such as those found in the Clitic Left Dislocation constructions in (34):

- (34) a. Unas cervezas (*las) compramos.
 some beers, them.ACC-PLUR-FEM we bought

“I bought some beers.”

b. A gente de la universidad (*la) visité.¹²

to people at the university them._{ACC·FEM} I visited

“I visited some people at the university.”

c. ¿Qué libros (*los) has comprado?

what books them._{ACC·PLUR·MASC} you have bought

“What books have you bought?”

d. A nadie (*lo) he visto.

to no one him._{ACC·MASC} I have seen

“We saw no one”

(Roca 1996: 86, 93).

e. (*Lo) buscaban a alguien.

him._{ACC·MASC} searched._{3·PLUR} to someone

“They were looking for somebody.”

(Cuervo 2003: 37)

All of the sentences including non-specific noun phrases above are only grammatical without the direct object clitic. This restriction contrasts with the relative freedom of indirect object clitics in Spanish, which can refer to both specific and nonspecific nominal expressions. Consider the ability of the dative clitic to be doubled by non-specific DPs in (35):

(35) a. Les expliqué lo sucedido a unos policías.

them._{DAT} I explained the happened to some police

¹² Even without the clitic, the example in (27c) may be ungrammatical in some Mexican dialects of Spanish. In those dialects, the singular noun *gente* (‘people’) is more acceptable in this sentence as a bare plural, *gentes* (‘people’) (p.c. Claudia Parodi).

“I explained what happened to some police officers.”

b. Le hablaré de este asunto a gente de la universidad.

them. DAT I will speak of this matter to people of the university

“I will speak of this matter to people at the university.”

c. ¿A quién le has dado el libro?

to whom them. DAT have you given the book

“To whom have you given the book?”

d. No le debemos nada a nadie.

no them DAT we owe nothing to no one

“We don’t owe anything to anyone.”

(Roca 1996: 85).

The contrast between sentences in (34) and (35) provides compelling evidence that the referential scope of the accusative and the dative clitic is not identical. But does this justify classifying DO and IO clitics as different syntactic categories? Could we instead say that both are nouns, with the DO clitic marked as [+specific] and the IO clitic as [+/- specific]?

Actually, as Roca (1996) correctly points out, the idea that DO clitics are strictly associated with specific meanings is not completely accurate. Consider the examples in (36):

(36) a. En Alemania, si lo ven a uno borracho, lo meten en la cárcel.

in Germany, if him-ACC.MASC they see to one drunk, him ACC.MASC they put in the jail

“In Germany, if they see anyone drunk, they put him in jail.”

b. No lo pueden tratar así a uno.

no him-ACC.NEUT they cannot treat this way to one

“They can’t treat people like that.”

(Roca 1996: 92, 97).

As we can see from these examples, direct object clitics are indeed compatible with nonspecific DPs. They co-occur with generic indefinite nouns, like *a uno borracho* (‘anyone drunk’) who gets caught on the street in Germany, in (34a). And they can occur with universally-quantified, non-specific indefinites such as *uno* (‘one’). Although non-specific, the DP doubles in (34) do possess quantificational import (Uriagereka 1999: 270). The fact that non-specific nouns can fall under the scope of clitics follows if clitics are determiners that get their range anaphorically. We assume then that in (36b) *lo* is the determiner that quantifies over *uno* ‘one,’ the restriction. The determiner hypothesis for clitics is further supported by the fact that the definite article in Spanish shares the same quantificational capabilities as the DO clitic. Compare the non-specific uses of the accusative-marked clitic in (36) with similar uses of the definite article in (37):

(37) a. Las ballenas están en peligro de extinción.

the whales are in danger of extinction

“Whales are in danger of extinction.”

b. El hombre es mortal.

the man is mortal

“Man is mortal.”

(Roca 1996: 106)

Definite articles in Spanish, like accusative-marked clitics, can thus appear with non-specific generic nouns (35a) and quantify universally (35b). Given these similarities between DO clitics and definite articles, we follow Uriagereka (1995) in postulating direct object clitics as of the

category determiner. Thus, we will adopt the model in Figure 2.1, which shows the first-merged (i.e., External Merge) position of DO clitics (Torrego 1985, Uriagereka 1988), for a simple sentence with a DO clitic such as in (38):

- (38) Juana la vio.
 Juana her._{ACC-FEM} saw
 “Juana saw her.”

Figure 2.6: DO Clitic as Head of DP—External Merge Position

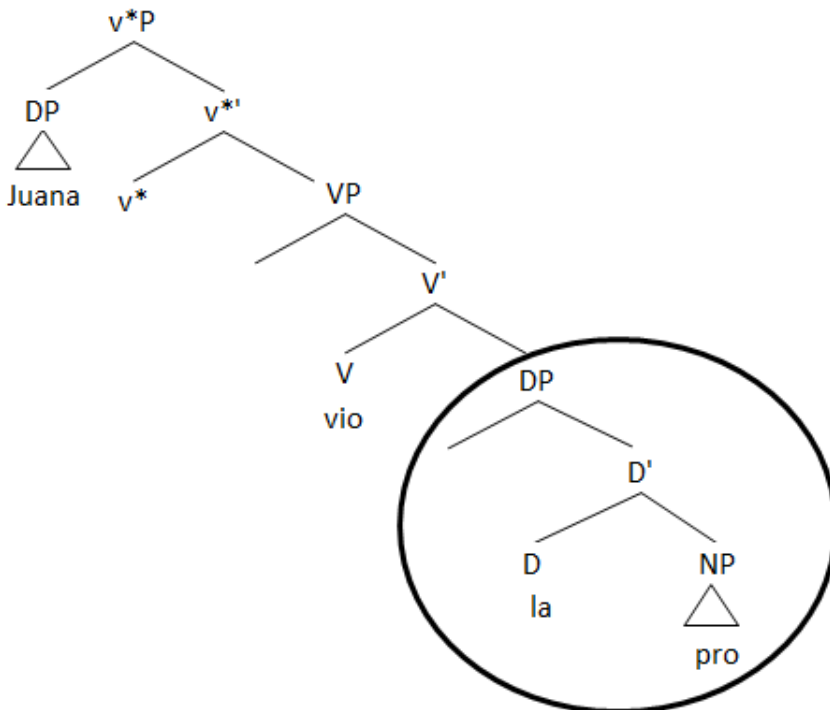

Uriagereka (1995: 81) argues convincingly that the above structure is motivated in Spanish, even apart from questions surrounding object clitics. This is because in many Romance languages, including Spanish, the English relative clause *the one who came from France* is expressed as *el/la que vino de Francia*, (‘the who came from France’) or as *el/la de Francia* (‘the from

France’). Thus, in Spanish, ‘the one’ which we might think of as [DP the [NP one]] in English, can be reduced to [DP el [NP pro]], or simply [DP [D el]], in Spanish. As this syntactic structure evidently exists for subject noun phrases such as *el de Francia*, it should in principle be available to objects as well, specifically object clitics.

Uriagereka (1995) refers to the Spanish determiner as a ‘strong determiner.’ In his account, Uriagereka distinguishes ‘weak determiners’ (like French object clitics that cannot be doubled) from strong determiners by assuming that strong determiners can project a double in their specifier, as well as a phonetically empty NP complement. These assumptions result in the following revision to the proposed structure in Figure 2.6, for a sentence with clitic doubling, such as the example in (39) where the DO clitic is doubled by a strong pronoun (*ella*) in Fig. 2.7:

- (39) Juana la vio a ella.
 Juan her._{ACC·FEM} saw to her
 “Juana saw her.”

Figure 2.7: DO Clitic and Double—External Merge Positions in the DP (Uriagereka 1995)

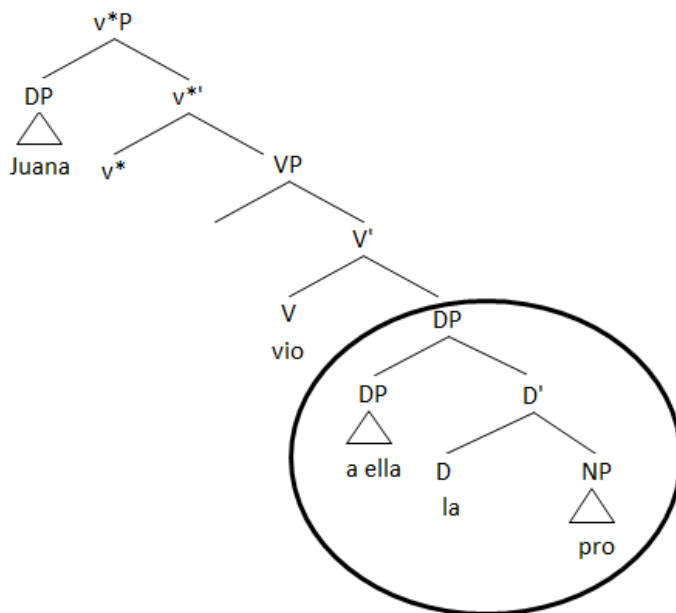

The model in Fig. 2.7 treats the doubled noun phrase *a ella* ('her') as being generated in apposition to the direct object clitic (an insight which Uriagereka attributes to Boas (1911)). Although we will adopt the structure for doubling depicted in Figure 2.7 for our own analysis, another possibility is to generate the clitic and its double in separate projections and later associate them via subsequent transformations in the interpretive component of the grammar, Logical Form (cf. Sportiche 1996, 1999). In our own account of clitic movement in Chapter 5, we put this question mostly to the side, as it does not affect the crucial points of our analysis. Nevertheless, we adopt Torrego and Uriagereka's intuition on this matter, which dates back to Bello (1847), that direct object clitics are determiners.¹³

Now, can we say that indirect object clitics in Spanish conform to the same syntactic characterization, that they are determiners? As we saw above with regard to the types of noun phrases that they can refer to, accusative clitics in Spanish seem to represent a subset of their dative counterparts. Recall from the examples in sentences in (34) and (35) that DO clitics can be associated with both specific and nonspecific meanings. However, the nonspecific meanings that can be associated with direct object clitics in Spanish are restricted to non-specific indefinites that can quantify generically or universally over all members of a set.

2.4 The Status of Indirect Object Clitics

Indirect object clitics in Spanish, on the other hand, can not only be associated with noun phrases that denote specific individuals or quantify generically or universally, but, as we saw in

¹³ Another piece of evidence that clitics resemble determiners comes from *wh*-expressions. In Spanish, the article *lo* can head the *wh*-DP, *lo que* (= *qué*) 'what', as in *No sé lo que me dijiste* 'I don't know what you told me.' The expression with the article, *lo que*, can alternate with the synonymous form *qué*, which does not take an overt determiner. In these cases, the article appears to be the quantifier, which takes scope over *que*, the restriction, in line with Uriagereka's assumptions about the scopal properties of definite determiners and direct object clitics (1995, 1999).

the examples in (35) above, IO clitics can also refer to so-called ‘pure’ (non-specific) indefinites (Uriagereka 1995: 90). In Spanish, pure indefinites include non-generic and non-universally quantified *uno* (‘one’), non-specific bare nouns such as *gente* (‘people’), negative quantified expressions such as *nadie* (‘no one’), *ninguna persona* (‘no person’), existential quantifiers such as *muchos* (‘many’), *suficientes* (‘enough’), *bastantes* (‘quite a few’), *algunos* (‘some’), and indefinite *wh*-elements such as *a quién* (‘to whom’), and *qué libros* (‘what books’). The ability to refer to pure indefinites, however, is not the only major factor that distinguishes direct and indirect object clitics in Spanish.

The other distinguishing factor between DO and IO clitics is, of course, the ability to appear doubled by a noun phrase in most types of constructions. In section 2.3 we saw that dative clitics can be doubled by any full DP, while accusative clitics can only be doubled in the same intonational contour by a co-referring strong pronoun (as in (29a)) or universal quantifier (as in (30)). In both (29) and (30), the DO clitic is the mandatory object element while its DP associate is optional. This is a strong piece of evidence that DO clitics are the mandatory internal arguments of the verbs that select them. The same restriction appears to apply to most indirect objects in Spanish, although the dative facts are more complex. In section 2.5, we will closely consider facts that lend credence to the idea that indirect object clitics are also arguments, and, given their similarity to DO clitics, also of the category determiner.

2.5 Two Types of Dative Constructions in Spanish

According to Strozer (1976), and subsequent major analyses of dative constructions in Spanish (e.g. Demonte 1995, Cuervo 2003), there are two distinct classes of indirect objects in Spanish. The first class mentioned above is composed of the so-called ‘ordinary’ goal datives

(Strozer refers to these IO's as 'IND 1'). According to the above authors, in these constructions the dative clitic is optional for speakers of many dialects, as in (40):

(40) Lola (le) dio la manzana a Pablo.

Lola (him._{DAT}) gave the apple to Pablo

“Lola gave the apple to Pablo.”

(Strozer 1976: 139)

The indirect objects that belong to this class of datives include the ‘goal’ indirect objects, which usually refer to the recipients of a ‘transfer.’ Fittingly, the verbs involved in this class of constructions include well-known verbs of transfer, such as *dar* ‘give’, *entregar* ‘deliver/hand over to’, *vender* ‘sell’, *comprar* ‘buy’, *enviar* ‘send’, *enseñar* ‘teach’, *presentar* ‘introduce’, *recomendar* ‘recommend’, *decir* ‘say/tell’, *hablar* ‘speak’ *sonreír* ‘smile’, *pertenecer* ‘belong to’, etc. (Strozer 1976: 143). Strozer notes that the verbs that belong to this class vary according to dialect, and thus it is possible that many of the verbs listed above mandatorily subcategorize clitics as the dative argument, depending on the dialect in question. However, the generalization is that IND 1 verbs of ordinary transfer do not require the use of the clitic.

The second class of indirect objects includes what were traditionally called ‘datives of interest,’ among others (in Strozer’s terminology this is ‘IND 2’). In this second class, there is a dative clitic that is always mandatorily pronounced in Spanish (even in the presence of a double), while the full DP double is merely optional, as in the ‘source’ dative construction in (41):

(41) El ratero *(le) robó las joyas (a su mejor amigo).

the pickpocket her._{DAT} stole the jewels (to his best friend)

“The pickpocket stole the jewels off his best friend.”

(Strozer 1976: 141)

Predicates belonging to this second class include verbs that are normally transitive or intransitive, but that get ‘dativized’ to affect an entity marked with dative case, including *comer* ‘eat’, *lavar* ‘wash’, *romper* ‘break’, *bajar* ‘lower’, *poner* ‘put’, *ocurrirse* ‘occur’, *olvidarse* ‘forget’, *arrepentirse* ‘repent’, *presentarse* ‘appear’, *escaparse* ‘escape’, etc. (Strozer 1976: 144). The indirect objects that get selected by these types of verbs are commonly referred to as ‘involved’ goals, in contradistinction to the ‘ordinary’ goals of the transfer verb class. The idea is that these IO’s are typically more involved or implicated in the action depicted by the verb than are mere recipients of a directional transfer. Consider for example, the following set of IND 2, among which we can delineate ‘possessor’ datives of transitive verbs, (42), ‘possessor’ datives of unaccusative existential verbs, (43), ‘affected’ goals of transitive verbs, (44) ‘affected’ goals of inchoative verbs, (45), ‘experiencers’ of psychological verbs, (46), as well as ‘ethical datives’, including ‘benefecatives’, (47), and ‘malefactivates’ (48):

- (42) Juan *(le) besó la frente a Valeria.
Juan her._{DAT} kissed the forehead to Valeria
“Juan kissed Valeria’s forehead.”
- (43) A Laura *(le) sobraron veinte pesos.
to Laura her._{DAT} remained twenty pesos
“Laura had twenty pesos left.”
- (44) Emilio *(le) rompió la radio a Valeria.
Emilio her._{DAT} broke the radio to Valeria
“Emilio broke the radio on Valeria.”

- (45) A Valeria se *(le) quemaron las tostadas.
to Valeria SE her._{DAT} burned the toasts
“The toast was burned on Valeria.”
- (46) A Pepe *(le) gustan los gatitos.
to Pepe him._{DAT} please the kittens
“Pepe likes kittens.”
- (47) Pablo *(nos) preparó sandwichitos de miga a todos.
Pablo us._{DAT} prepared sandwiches of crumb to everyone
“Pablo fixed us all tea sandwiches.”
- (48) Pepe *(le) comió la tarta a su hermano.
Pepe him._{DAT} ate the pie his to his brother
“Pepe ate the pie on his brother.”
(cf. Cuervo 2003: 29-30).

Although there are a large variety of syntactic configurations that get included under the umbrella of IND 2 constructions in (42)-(48), the unifying element that licenses all of these structures is the dative clitic. It is also worth mentioning that said clitic is able to project (an optional) noun phrase double in each of the above expressions.¹⁴ This parallels closely the instances of doubling of the accusative clitic by its strong pronoun associate (cf. (Fig. 2.2)). In both cases, the clitic is the mandatory element that appears to absorb object Case, which in turn

¹⁴ There is some confusion in the literature about whether ‘ethical’ datives can be doubled. For most speakers, ethical datives, and most of the other involved goals of IND 2, can be readily doubled. As we will see shortly though, there are clitics that cannot be doubled, including ‘speaker’ dative clitics (Strozer 1976: 146) and ‘inherent’ reflexive clitics (Strozer 1976: 241).

forces the doubled noun phrase to be licensed via a preposition or Case-marking morpheme (i.e. Spanish *a*, whose categorial status we will discuss in the following section)¹⁵.

With such a parallelism in mind, it makes sense to continue to hold to the null hypothesis that the clitic is itself the dative argument in all IND 2 configurations—especially given that Spanish is not a null object language in dative constructions. Its categorial status should also be that of a determiner, albeit a non-definite determiner, as we saw that its semantic range does not exactly match that of definite determiners/accusative clitics. Regardless of semantic differences, we assume these elements are identical in terms of their syntax (i.e. they are determiners that enter the syntax carrying a Case feature that needs to be deleted). This conclusion is further bolstered by diachronic evidence, in these elements' similar evolution from pronouns in Latin, as well a handful of synchronic (dialectal) variation, in which copies of both accusative and dative clitics surface in base and derived positions. Yet, before we examine such evidence closely, there remains the question of how to distinguish between IND 1 and IND 2. Are indirect objects a unified class in Spanish? To attempt an answer at this question, let us pause again to reflect on the diverse array of constructions that Strozer et al. classify as IND 2.

Upon first glancing at the Spanish sentences, their glosses, and English translations in (42)-(48), it is striking how each one needs to be radically reworded to express the corresponding thought in English. Most of the sentences in this class cannot be literally translated to English, and this is mostly indicative of the fact that in Spanish the dative is employed in a much wider variety of syntactic constructions than it is in English. In English, the dative is limited to two

¹⁵ As we mentioned in the outline of the present volume (sec. 1.2), this principle was discovered by Kayne (1975), and is, accordingly, known as 'Kayne's Generalization'.

basic types of constructions: the prepositional dative construction, as in (49), and the double object construction, as in (50):

- (49) I fed beef to the hungry cat.
I fed [DP beef] [PP to the hungry cat]
- (50) I fed the hungry cat beef.
I fed [DP the hungry cat] [DP beef]

The difference in the structures above is often referred to as the dative alternation, since the direct and indirect objects switch places. In the prepositional dative (PPD), the direct object precedes the oblique indirect object. In the double object construction (DOC), the IO comes before the DO. Beyond a difference in nomenclature and surface order of internal arguments, this distinction between the two types of dative constructions in English has recently become significant from a theoretical perspective, and, as we will see shortly, has important implications for the derivation of dative constructions in Spanish. The dative alternation is discussed at length in Larson (1988), where the author examines binding data to determine whether the direct object theme or the indirect object goal has a closer relation to the verb. First, consider the following data in dative constructions that take a preposition:

- (51) a. I showed Mary_i to herself_i.
b. *I showed herself_i to Mary_i.
- (52) a. I sent [every check]_i to its_i owner.
b. ??I sent his_i paycheck to [every worker]_i.
- (53) a. I sent no presents to any of the children.
b. *I sent any of the presents to none of the children.

- (54) a. Which check did you send to whom?
 b. *Whom did you send which check to?

The pairs of sentences above each represent a configuration in which c-command matters. In (51), the reflexive must be c-commanded by Mary to satisfy Principle A of Binding Theory. In (52), the pronoun must be c-commanded by the quantifier in order to be interpreted as a bound variable. In (53) the negative polarity item *any* must be c-commanded by the expression headed by the negative quantifier *no/none* in order to be licensed. And in (54), a *wh-expression* cannot move to [Spec, CP] crossing another *wh-expression* that c-commands it, since this would be a violation of Superiority, or the Minimality Condition (see chapter 4).¹⁶ In order for these binding data to obtain, the DP theme (direct object) must c-command the goal PP in these prepositional dative constructions. The order of merger then should be something like the depiction in Figure 2.8, inside the first Larsonian verbal shell (VP), for sentences (51)-(54):

Figure 2.8: The Base Configuration of Prepositional Dative Constructions

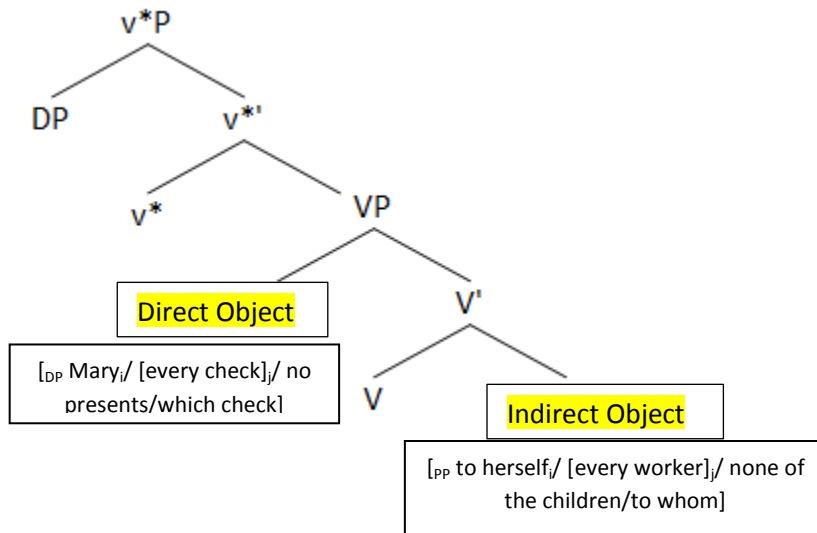

¹⁶ See Hornstein et al. (2005: 93) for further helpful breakdown of the data discussed in Barss and Lasnik (1986), Larson (1988).

Interestingly, the binding data imply a different order of arguments in double object constructions. Observe the following alternations of objects in these configurations:

- (55) a. I showed Mary herself.
b. *I showed herself Mary.
- (56) a. I sent [every worker]_i his_i paycheck.
b. *I sent its_i owner [every paycheck]_i.
- (57) a. I showed no one anything.
b. *I showed anyone nothing.
- (58) a. Whom did you give which pay check?
b. *Which paycheck did you give who?
- (cf. Larson 1988: 336-337)

In otherwise identical sentences, the c-command situation changes markedly from prepositional datives to double object constructions. In the latter, as we can see in (55)-(58), it is the dative goal of each construction that c-commands the direct object theme. This led Larson to conjecture that the merger order of internal arguments is reversed for double object constructions, and that it is the DO that is first merged as the complement of V, while the dative argument is merged in [Spec, VP], after the initial merger between verb and direct object occurs. This order of arguments is sketched out in Figure 2.9, for sentences (55)-(58):

Figure 2.9: The Base Configuration of Double Object Constructions

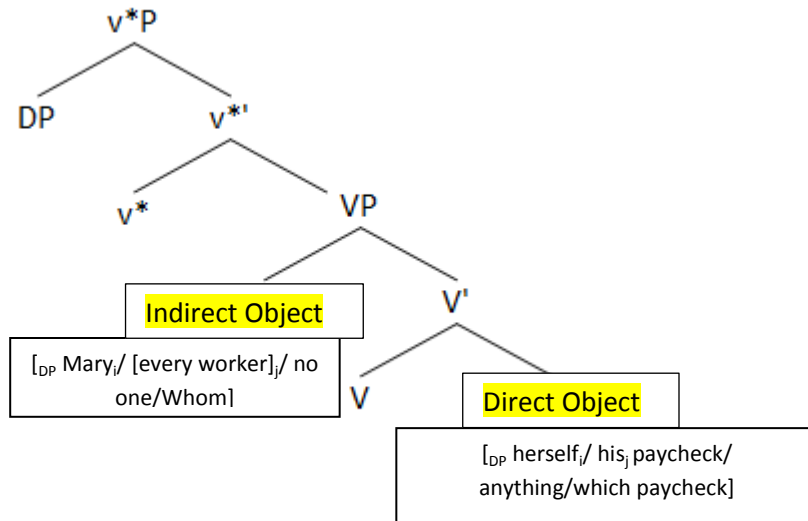

Does a similar alternation obtain in Spanish? According to Demonte (1995) and Cuervo (2003), yes. Moreover, the dative alternation in Spanish, they claim, corresponds closely to the difference between Strozer’s IND1 and IND 2. Consider the following pairs of sentences, which can alternate between IND 2 constructions (a) and IND 1 constructions (b) in Spanish:

- (59) a. Pablo le mandó un diccionario a Gabi.

Pablo her._{DAT} sent a dictionary to Gabi

“Pablo sent Gabi a dictionary.”

- b. Pablo mandó un diccionario a Gabi.

Pablo sent a dictionary to Gabi

“Pablo sent a dictionary to Gabi.”

- (60) a. Pablo le puso azúcar al mate.

Pablo it._{DAT} put sugar to the mate

“Pablo put sugar in the mate.”

- b. Pablo puso azúcar en el mate.

Pablo put sugar in the mate

“Pablo put sugar in the mate.”

- (61) a. Pablo le lavó la bicicleta a Andreína.

Pablo her._{DAT} washed the bicycle to Andreína

“Pablo washed Andreína’s bicycle.”

- b. Pablo lavó la bicicleta de Andreína.

Pablo washed the bicycle of Andreína

“Pablo washed Andreína’s bicycle.”

(Cuervo 2003: 46).

Demonte (1995) argues at length that the alternation observed in these sentences parallels the dative alternation in English. Through a series of syntactic tests, (i.e. binding, weak crossover, scope) that resemble the tests on both types of datives performed by Larson (1988), Demonte argues that the (b) sentences, without the clitic, are prepositional datives (PPD), while the (a) sentences, in which the clitic is pronounced, are double object constructions (DOC).

Accordingly, Demonte observes that in the Spanish sentences with dative clitics, the indirect object can be shown to bind and hence c-command the direct object, while in sentences without the clitic, the direct object c-commands the indirect object. Observe the sentences in (62), where a DP in a possessive structure must be bound by a c-commanding antecedent, with a sketch of (62b) in Figure 2.10:

- (62) a. *Presentamos a su_i paciente a la doctora_j.

pro we introduced her patient to the doctor

“*We introduced her_i patient to the doctor_i.”

- b. Presentamos a la doctora_j a su_i paciente.

- pro we introduced to the doctor to her patient
“We introduced the doctor to her patient.”
- c. Le_i presentamos su_i paciente a la doctora $_i$.
pro her._{DAT} we introduced her patient to the doctor
“We introduced the doctor her patient.”
- d. * Le_i presentamos la doctora a su_i paciente.
her._{DAT} we introduced to the doctor to her patient
“*We introduced her patient the doctor.”
- (Cuervo 2003: 55)/
(Ormazabal and Romero 2013: 321)¹⁷

Figure 2.10: v-phase Derivation of Arguments in Prepositional Dative Constructions in Spanish (ex. *Presentamos a la doctora a su paciente*)

¹⁷ As Ormazabal and Romero (2013) point out for examples such as (62c) and (62d) the presence of the IO clitic *le* in these sentences creates the only context in Spanish where *a* need not precede animate specific DOs, such as *paciente* (‘patient’). However, as we observe in sentences (62a) and (62b), *a* can readily introduce both IO and DO when there is no dative clitic present, in prepositional dative structures.

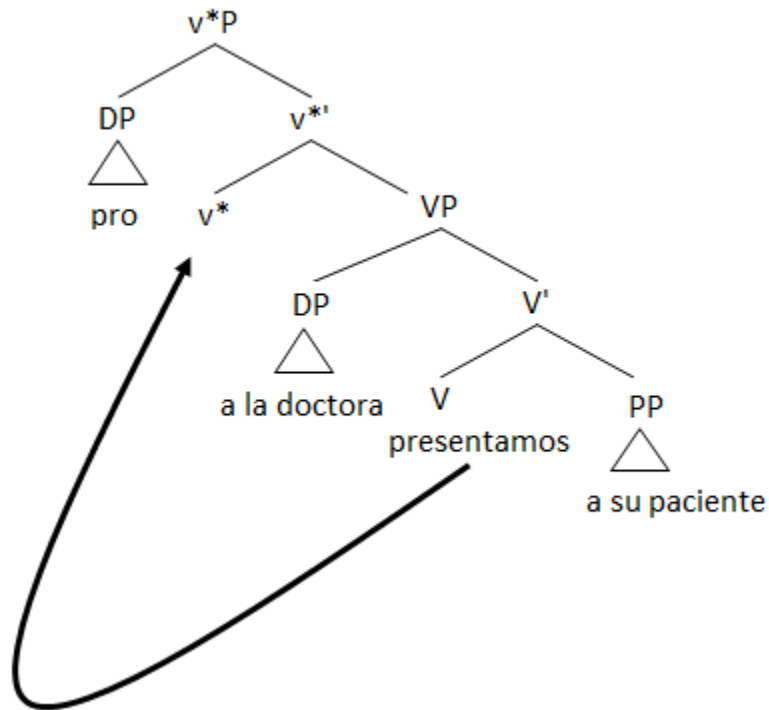

In the prepositional dative sentence in (62a), the possessive *su* ('her') in the direct object cannot be bound by the IO goal. If, though, as in (62b), the possessive *su* belongs to the complement of the preposition, as sketched above in Fig. 2.10, the sentence is grammatical, and the DO DP *la doctora* ('the doctor') binds the possessive element in the IO. Now observe what happens when a dative clitic is inserted, as in (62c), visualized in Fig. 2.11:

Figure 2.11: v-phase Derivation of Arguments in Double Object Constructions in Spanish
 (ex. *Le presentamos su paciente a la doctora*)¹⁸

¹⁸ In Figure 2.6, verb movement is assumed to take place from V-v, but is not shown, in order to focus attention on the movement of the DO and IO arguments.

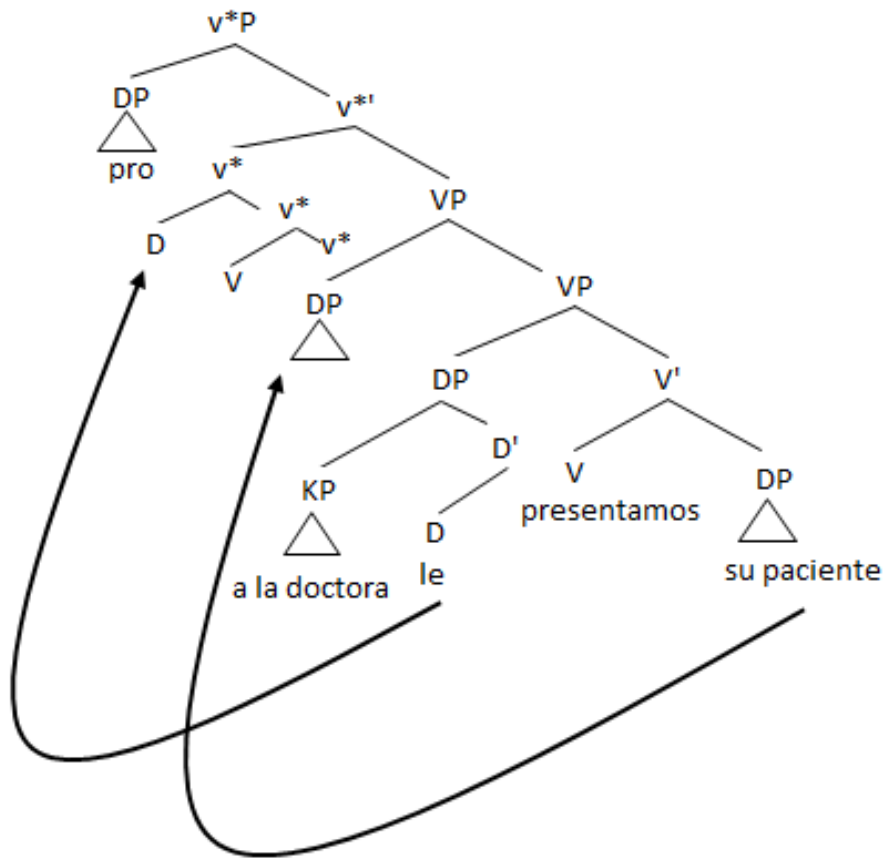

In the Spanish sentence in (62c) with the dative clitic *le*, possessive *su* ('her') in the theme object can be bound by the dative element, even when the IO double appears to the right of the direct object on the surface. This follows naturally if we assume that dative clitic *le* is actually the dative DP in the double object construction, where the IO c-commands the DO. We accomplish this derivationally in Fig. 2.11 by generating the IO clitic and its double together in [Spec, VP]. The DO *su paciente* ('her patient') moves from its theta-position to its Case position, the higher [Spec, VP]. The dative clitic then moves, with the verb, to the little *v*.

The example in (62d) further supports Demonte's argument, as the DO DP cannot bind the possessive in the prepositional goal when the dative clitic is present in the structure. Once

again, this makes sense if we assume that a DO first merged in the complement of V cannot bind an element belonging to its antecedent in the structure. Also, consider what happens if a locative is added to a structure with the dative clitic:

- (63) a. Pablo le mandó un diccionario a Gabi a Barcelona.
Pablo her._{DAT} sent a dictionary to Gabi to Barcelona
“Pablo sent Gabi a dictionary to Barcelona.”
- b. ??/* Pablo mandó un diccionario a Gabi a Barcelona.
Pablo sent a dictionary to Gabi to Barcelona
“*Pablo sent a dictionary to Gabi to Barcelona.”
- (Cuervo 2003: 49)

While the sentence in (63a) is perfectly acceptable, the (b) sentence without the clitic is seriously degraded. This is expected if the dative clitic is the licensing element for the DP dative (*Gabi*). When there is already a true PP in the locative goal position (*a Barcelona*), the other dative must receive inherent dative case (from the verb), and c-command the other internal arguments, as in the English parallel of this alternation (where *Daniel* is the dative DP):

- (64) a. Stephanie sent Daniel a letter to his office.
b. *Stephanie sent a letter to Daniel to his office.

The only obscuring factor that prevents a complete parallelism between Spanish and English here is the presence of the morpheme *a* in both types of Spanish constructions in (59)-(61). If the IND 2 constructions are actually double objects, how do we explain the presence of the preposition *a* with the stressed dative DP (in 61a)? A clue to this puzzle is provided by Masullo (1992). Expanding on the arguments made by Demonte, Masullo argues that the *a* of

each construction (IND 1 v. IND 2) must be underlyingly different. In the prepositional dative construction of (62b), he claims the dative *a* is a content preposition heading a PP (e.g. ‘*a su paciente*’). In the double object construction of (62c), on the other hand, the dative *a* is a case marking morpheme that syntactically licenses the DP double (*à la* Kayne’s generalization).

Instead of being licensed by a PP, the doubled element in IND 2 sentences gets introduced by a Case phrase (KP) that is morphologically realized as a preposition. Given this reasoning, the parallel between the English and Spanish constructions becomes clearer—in both languages, prepositional datives are PPs while the double object dative is a DP. This claim also amounts to saying that the clitic is always obligatory in IND 2 constructions (where the verb assigns dative case structurally). When there is no clitic, there is no ‘dative’ case to be assigned by the verb. This provides a plausible explanation of what is at stake in terms of IND 1 v. IND 2, and also suggests the external merge order of these constituents in Spanish: in IND 2 sentences, dative clitics first-merge as nouns in [Spec, VP]. In IND 1, where there is no dative clitic, the IO gets merged first with the verbal root, as the prepositional complement of V¹⁹, and the DO externally merges in [Spec, VP].

In a double object construction with two clitics, such as *Se lo puso* (i.e., the clitic-cluster rendering of (60a) -- *Pablo le puso azúcar al mate* (‘Pablo put the sugar in the mate’)), the dative clitic starts out above the accusative clitic, c-commanding the DO, which starts as the nominal complement of Root V. This is shown in Figure 2.12:

¹⁹ Further evidence of this proposed merge order for internal arguments in Spanish dative constructions, including ethical datives, comes from dialects of English. Colloquial variants of American English, especially found in the Deep South, employ what appears to be an ethical dative pronoun, in contexts especially related to hunting and fishing. For instance, “I’m gonna shoot **me** a squirrel” or “I’m gonna catch **me** a barracuda.” In these constructions, the benefactive dative *me* c-commands the direct object, which squares with the external merge order we have proposed for Spanish IND 2 configurations above. Thanks to Tim Stowell for this observation and connection between ethical datives in English and Spanish (p.c.)

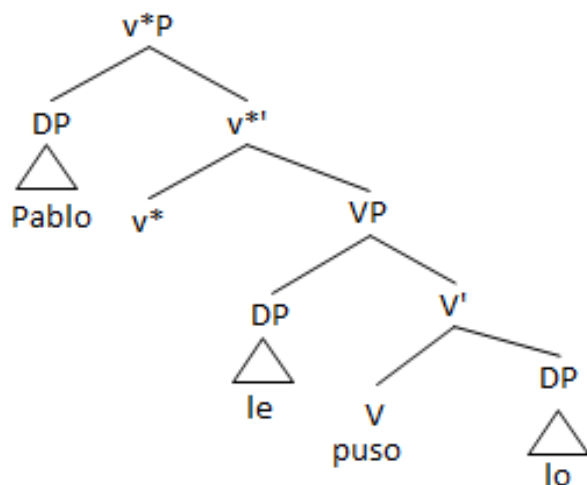
Figure 2.12: External Merge Positions of IO and DO Clitics in Double Object**Constructions**

In the formal analysis in Chapter 5 of double object constructions with clitics, we will explain why and how the clitics in Fig. 2.12 move from their thematic positions to attaching proclitically to the verb. In addition, we assume that the underlying form of *spurious se* is the dative-marked *le*, which subsequently gets transformed into opaque form *se* at PF.

2.8 Evolution of Accusative and Dative Clitics from Latin

Having reviewed argument for the nominal status of both accusative and dative clitics in modern Standard Spanish, as well their merge order in the syntax, let us finish with our review of the evidence that links these elements together and confirms the intuition that they are both pronouns. Consider for a moment the diachronic evidence, and the evolution of these elements from Latin. The historical origins of clitic pronouns are fairly clear: the first and second person forms of modern Spanish object clitics, both accusative and dative, (*me*, *te*, *nos*, *os*) derive from

the stressed accusative pronouns of Latin (MĒ, TĒ, NŌS, VŌS). In spoken Latin, it was common to replace the corresponding dative forms (MIHĪ, TIBĪ, NŌBĪS, VŌBĪS) with the accusative forms (Penny 2002: 135), and this explains why these forms are homophones in modern Spanish. Since Latin had specifically personal pronouns only for the first and second persons, demonstrative forms were used for the third person pronouns (Penny 2002: 133). Among a variety of demonstrative options to choose from in Latin (e.g. IS, HIS, ISTE, ILLE), ILLE came to be preferred in the role of third person pronoun and provides Spanish with the base of its third person forms (i.e., *él*). The third person accusative clitics of modern Spanish (*lo(s)/la(s)*), derive from demonstrative forms related to ILLE, namely ILLUM, ILLAM, ILLOS, and ILLAS. Similarly, the third person dative Spanish clitic form (*le(s)*), derives from dative demonstratives ILLĪ and ILLĪS, which were the only dative pronominal forms not to be replaced in spoken Latin by accusative forms, as came to be the case in modern Spanish. The Spanish clitic forms and the Latin forms from which they are descended are shown in Table 2.2:

Table 2.2: Evolution of Spanish Clitics from Latin

Person	1 st		2 nd		Accusative (3 rd)		Dative (3 rd)	
	Latin	Spanish	Latin	Spanish	Latin	Spanish	Singular	Plural
Singular	MĒ	me	TĒ	te	ILLUM, ILLAM	lo, la	ILLĪ	le
Plural	NŌS	nos	VŌS	os	ILLOS, ILLAS	los, las	ILLĪS	les

In the case of Spanish clitic pronouns, the direct object forms of Latin eventually became atonic and, where not already the case, monosyllabic. A related change was the eventual cliticization of these forms, in which they became a single phonological word with their host. Because of the loss of tonicity of this class of pronouns, direct and indirect object forms of ILLE show early

reduction of –LL– to /l/, and therefore escape the palatalization of –LL– > /ʎ/ which occurs regularly in subject and tonic object forms in many dialects of Spanish, i.e., (a) *ellos* (Penny 2002: 135). In summary, the first and second person clitic forms of Spanish share the same diachronic origin, as do third person accusative and dative clitics. All descended from tonic pronouns in Latin. It is worth noting then that at least from a historical perspective, it makes sense to categorize accusative and dative clitics as the same type of grammatical element, especially in dialects that do not permit DO doubling, and hence obeys Kayne’s Generalization. In these dialects, it is likely that both DO and IO clitics have retained their pronominal function. Hence, a movement account of Spanish clitics is still needed, despite the recent popularity of base generation analyses that well explain doubling phenomena, but do not fare as in explaining data related to clitic climbing, to be explored in the next section.

2.7 Conditions on Clitic Climbing

Assuming then that clitics are internal arguments, at least in the standard, non-doubling, dialects of Spanish, then these clitics must reach their surface proclitic positions via a transformation. The mechanisms responsible for clitic movement not only displace clitics to the front of the verbs that subcategorize them, but also yield configurations in which clitics find themselves attached to verbs with which they are semantically unrelated. The most common case is clitic climbing. Clitic climbing is optional, as we can see in (65):

- (65) a. Pepe la quiso escribir.
Pepe it._{ACC.FEM} wanted write._{INF}
“Pepe wanted to write it.”
b. Pepe quiso escribirla.

Pepe wanted write._{INF} it._{ACC.FEM}

“Pepe wanted to write to it.”

If climbing to the higher verb in (65) is not evocative enough of movement, consider (66), where the clitic can end up in four different locations across the span of five different verbal forms:

(66) a. Este libro, yo **lo** estoy deseando haber podido leer.

this book, I it._{ACC.MASC} I am wanting have._{INF} able._{PPRT} read._{INF}

“This book, I am wanting to have been able to read it.”

b...yo estoy deseando**lo** haber podido leer.

I am wanting it._{ACC.MASC} have._{INF} able._{PPRT} read._{INF}

“I am wanting to have been able to read it.”

c...yo estoy deseando haber**lo** podido leer.

I am wanting have._{INF} it._{ACC.MASC} able._{PPRT} read._{INF}

“I am wanting to have been able to read it.”

d...yo estoy deseando haber podido leer**lo**.

I am wanting have._{INF} able._{PPRT} read._{INF} it._{ACC.MASC}

“I am wanting to have been able to read it.”

e...*yo estoy deseando haber podid**o** leer.

I am wanting have._{INF} able._{PPRT} it._{ACC.MASC} read._{INF}

“I am wanting to have been able to read it.”

f...*yo estoy **lo** deseando haber podido leer.

I am it._{ACC.MASC} wanting have._{INF} able._{PPRT} read._{INF}

“I am wanting to have been able to read it.”

(example adapted from a similar sentence in Boeckx and Gallego 2008: 6)

As we can see from (66e) and (66f) above, the clitic cannot move to every conceivable attachment site. In (66e), the clitic cannot attach to the past participle *podido* ('able'). Although clitics cannot attach to past participles, they can attach to present participles, as in *deseándolo* ('wanting it'). Furthermore, the clitic cannot attach to the finite auxiliary form of *estar* ('be') in (66f). This is due to the fact, of course, that in Spanish, finite verbs cannot take enclitics.

In line with our argument that accusative and dative clitics should be treated equally in the syntax, we see that the same type of 'cyclic' climbing behavior is observed with 'clitic clusters' (i.e. a consecutive sequence of two or more clitics). Both direct object clitic (*lo*) and indirect object clitic (*me*) can also climb together in a multi-verb sequence, as in (67):

- (67) a. Ella deseaba seguir gritándomelo.
she wanted continue.INF shouting me.DAT it.ACC.MASC
"She wanted to continue shouting it to me."
- b. Ella deseaba seguirme lo gritando.
she wanted continue.INF me.DAT it.ACC.MASC shouting
"She wanted to continue shouting it to me."
- c. Ella me lo deseaba seguir gritando.
she me.DAT it.ACC.MASC wanted continue.INF shouting
"She wanted to continue shouting it to me."

(Strozer 1976:282)

Adding more intervening verbal forms most clearly shows the striking parallel between the climbing of one clitic and the climbing of the two clitics in tandem, verb by verb, as in (68):

- (68) a. **Yo te lo** estoy deseando haber podido explicar.

I you.DAT it.ACC.MASC am wanting have.INF able.PPRT explain.INF

“I am wanting to have been able to explain it to you.”

- b. Yo estoy deseando **te lo** haber podido explicar.

I am wanting you.DAT it.ACC.MASC have.INF able.PPRT explain.INF

“I am wanting to have been able to explain it to you.”

- c. Yo estoy deseando habér**te lo** podido explicar.

I am wanting have.INF you.DAT it.ACC.MASC able.PPRT explain.INF

“I am wanting to have been able to explain it to you.”

- d. Yo estoy deseando haber podido explicár**te lo**.

I am wanting have.INF able.PPRT explain.INF you.DAT it.ACC.MASC

“I am wanting to have been able to explain it to you.”

- e. *Yo estoy **te lo** deseando haber podido explicar.

I am you.DAT it.ACC.MASC wanting have.INF able.PPRT explain.INF

“I am wanting to have been able to explain it to you.”

- f. *Yo estoy deseando haber podido **te lo** explicar.

I am wanting have.INF able.PPRT you.DAT it.ACC.MASC explain.INF

“I’m wanting to have been able to explain it to you.”

Another important restriction on clitic movement is that it is not possible for one object clitic to move higher while the other stays below. Both accusative and dative clitics must climb together:

- (69) a. Pepe me la quiso escribir.

Pepe me.DAT it.ACC.FEM wanted write.INF

“Pepe wanted to write it to me.”

b. *Pepe me quiso escribirla.

Pepe me._{DAT} wanted write._{INF} it._{ACC-FEM}

“Pepe wanted to write it to me.”

c. *Pepe la quiso escribirme.

Pepe it._{ACC-FEM} wanted write._{INF} me._{DAT}

“Pepe wanted to write it to me.”

(Strozer 1976: 16).

The requirement that clitics subcategorized by the same verb move together holds even we expand the number of verbs that the clitics can move to, as in (70):

(70) a. Pepe me las deseaba seguir gritando. (*las*= *las groserías*, ‘the obscenities’)

Pepe me._{DAT} them._{ACC-FEM} wanted continue._{INF} shouting

“Pepe wanted to continue shouting them at me.”

b. *Pepe deseaba seguirme gritándolas.

Pepe wanted continue._{INF} me._{DAT} shouting them._{ACC-FEM}

“Pepe wanted to continue shouting them at me.”

c. *Pepe me deseaba seguirlas gritando.

Pepe me._{DAT} wanted continue._{INF} them._{ACC-FEM} shouting

“Pepe wanted to continue shouting them at me.”

d. *Pepe me deseaba seguir gritándolas.

Pepe me._{DAT} wanted continue._{INF} shouting them._{ACC-FEM}

“Pepe wanted to continue shouting them at me.”

Another restriction on clitic climbing is that not all ‘embedding’ verbs can attract clitics. Strozer (1976: 282) notes that clitics seem to always be able to climb up to some verbs, such as *querer/desear* ‘want’, *poder* ‘able to’, while with other verbs, such as *esperar* ‘hope’, *preferir* ‘prefer’, she claims there is a considerable amount of variation among speakers regarding the acceptability of climbing. With other verbs, such as *jurar* ‘swear’, ‘promise’, *temer* ‘fear’, *creer* ‘believe’, etc., native speakers tend to completely reject the clitic to the left of the finite form. In these last cases, the clitic must stay attached to the lower infinitive.

- (71) a. Juro amarte.
 I promise love.INF you.CL
 “I promise to love you.”
- b. *Te juro amar.
 you.CL I promise love.INF
 “I promise to love you.”

In Tables 2.3 and 2.4, we list common verbs that allow and disallow clitic climbing in Spanish:

Table 2.3: Common Spanish Verbs that Allow Clitic Climbing

Verbs that Allow Clitic Climbing	Meaning	Verbs that Allow Clitic Climbing	Meaning
soler	usually	dejar	allow
acabar (de)	just finish	volver	begin again
querer	want	mandar	order
tratar (de)	try	permitir	permit
poder	be able to, may	ir a	go to
deber	must	venir	come
empezar (a)	begin	aprender	learn
ver	see	estar	be
desear	want	andar	go

seguir	continue	tener (que)	have to
saber	know	intentar	try

Table 2.4: Common Spanish Verbs that Disallow Clitic Climbing

Verbs that Disallow Clitic Climbing	Meaning	Verbs that Disallow Clitic Climbing	Meaning
parecer	seem	confesar	confess
insistir	insist	afirmar	affirm
soñar (en)	dream about	desear	desire
odiar	hate	deplorar	deplore
estimar	esteem	jurar	swear
evitar	avoid	creer	believe
dudar	doubt	admitir	admit
negar	deny	asegurar	assure
haber (que)	have to	lamentar	regret
temer	fear	renunciar (a)	refuse to
convenir	agree to	morir (por)	dying to

(Strozer 1976: 296-300, Luján 1993: 236-242)

It appears that whether or not a verb permits clitic climbing depends on the idiosyncratic requirements of the verb. It is often asserted that climbing is only possible when the embedding verb is functional, not lexical (as observed by Boeckx and Gallego 2008: 5). Such arguments might well be applied to auxiliary phrases such as *estar* + gerund ‘be + gerund’ and *ir a* ‘go to’, epistemic modals such as *poder* ‘may’ and *deber* ‘must’, aspectual verbs such as *soler* ‘usually’, *empezar a* ‘begin to’, *acabar de* ‘just finish’, and *continuar* ‘continue’, and verbs of motion like *venir* ‘come’ and *andar* ‘go’. However, the generalization seems difficult to apply to other clitic climbing verbs that very much appear to be lexical, such as *querer* ‘want’, *saber* ‘know’, *aprender* ‘learn’, *intentar* ‘try’, *permitir* ‘permit’, *dejar* ‘allow’, *ver* ‘see’, *mandar* ‘order’, *tratar*

de ‘try’, etc. Although we readily assume that functional auxiliaries originate in the same clause as the lower verb, we will not consider a monoclausal restructuring of lexical verbs in clitic climbing structures (cf. Cinque 2006).

Thus, instead of adopting a strictly monoclausal approach to clitic climbing, where there are no intervening inflectional nodes (i.e., C or T) between the matrix and embedded verbs, we will advocate for a biclausal analysis of clitic climbing, but one in which the embedded clause is ‘defective’ (cf. Chomsky 2001, 2008; Solà 2002). Under this conception, the C-phase of the embedded clause is defective because it is assumed to lack the features associated with finite C (cf. Chomsky 2008, 2013). This defective phase (‘C_{def}’) is minimally composed of T. Transparency effects related to ‘restructuring’ are then ascribed to the fact that C_{def} is defective and does not induce the PIC, since C_{def} is not a functioning phase head. This can be visualized in Figure 2.13, a sketch of the derivation of example (72):

- (72) Ella lo desea [saber t_{io}]
 she it._{ACC.MASC} wants know._{INF}
 “‘She wants to know it.’”

Figure 2.13: Biclausal Derivation of Clitic Climbing Structures



In Fig. 2.13, the clitic *lo* first moves to the Edge of the lower v-phase. From the edge of vP, it is visible to the finite verb *desea* ('wants'), which attracts the clitic into its (minimal) edge upon Agreeing with the clitic in phi-features and valuing its Case as accusative. Agreement between the finite verb and the embedded object clitic is possible in Fig. 2.13 because C_{def}/T is defective, and thus does not constitute a phase. If it were a full CP, the embedded clause would be opaque to *desea* and clitic climbing would not obtain, as we will see with classic examples of intervention effects and islands that block clitic climbing in section 2.8.

Therefore, in our analysis, a higher probe can penetrate C_{def} to find matching goals on T or even in the Edge of the lower phase, headed by v^* . We find the conception of biclausality

outlined in Figure 2.13 to be preferable to a monoclausal approach in that it acknowledges the reduced nature of structures involved in clitic climbing constructions, but keeps to the optimal assumption that main verbs always select clausal complements.

A strong empirical argument in favor of positing an intervening C_{def}/T , and hence two clauses, comes from the behavior of clitics that attach to the finite matrix verb of ECM clauses. As we will see in detail in the next section of this chapter (2.8), there are structures in Spanish in which embedded object clitics are prevented from moving around their lexically specified subjects and onto the matrix verb. This condition on clitic movement is well known and was originally attributed to the Specified Subject Condition (SSC) (Kayne 1975, Quicoli 1976). The SSC was invoked to explain the ungrammaticality of sentences like (73):

- (73) a. *La vi [al médico examinar t_{la}]. (*la*= *la muestra*, ‘the sample’)
 it._{ACC.FEM} I saw to the doctor examine._{INF}
 “I saw the doctor examine the sample”
 (Quicoli 1976: 205, translated to Spanish from Portuguese)
- b. *Pedro lo hizo [a Juan leer t_{lo}]. (*lo*= *el libro*, ‘the book’)
 Pedro him._{ACC.MASC} made to Juan read._{INF}
 “Pedro made Juan read it.”
 (Ordóñez 2012: 438)

In (73b), the direct object clitic *lo* of the lower clause cannot move over the intervening subject DP *a Juan* to attach to the finite form of the causative verb *hacer* (‘make’). However, in Spanish, it is acceptable to lift the DO clitic over the intervening subject in (73b) if the lower verb is ‘inverted’ and placed in front of its subject DP, as in (74), derived in Fig. 2.14:

(74) Pedro lo hizo [_{Cdef} [_T leer_v [a Juan t_v t_{lo}]]].

Pedro it._{ACC-MASC} made read._{INF} to Juan

“Pedro made Juan read it.”

Figure 2.14: Embedded Verb Inversion in Clitic Climbing in Spanish

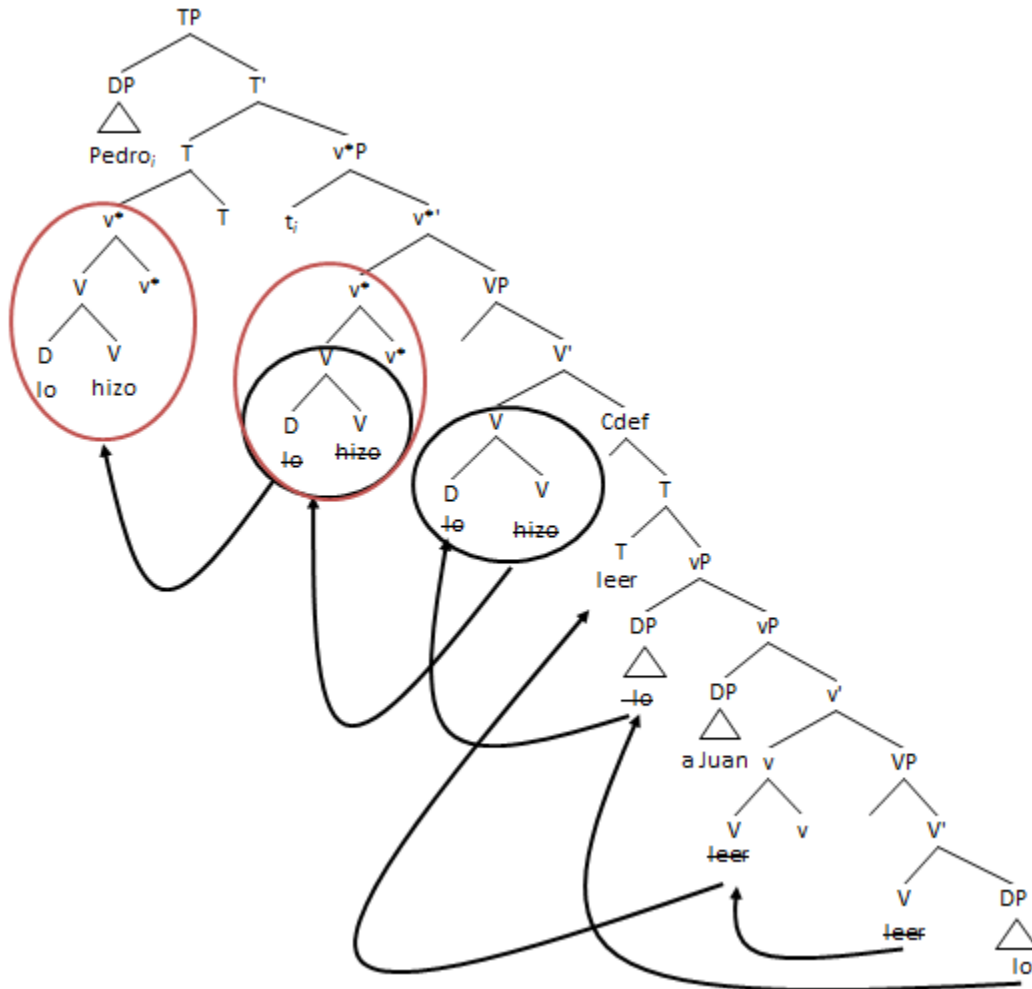

In the bracketed example in (74) and sketch in Fig. 2.14, the embedded infinitive *leer* (‘read’) inverts around the embedded subject, *a Juan*, and settles in T of the defective phase C_{def} (à la standard v-T movement in Spanish finite clauses). The clitic *lo* once again moves from its theta-position to the Edge of the v-phase, and then incorporates onto to the finite verb in the higher

clause, with which it moves all the way to matrix T. Our analysis of clitic movement in ECM/causative sentences will be presented in full in Chapter 5, but the main point to be made here is that for the embedded verb to invert in example (74), there needs to be an available landing site (e.g., T)—this position is lacking in monoclausal restructuring. Another suggestive piece of evidence in favor of biclausality in ECM/causative structures with clitic climbing in Spanish is the fact that three clitic object arguments can be licensed in these configurations:

- (75) *Lo_i hice [t_i escribírmelo].*
 him_{.ACC·MAC} I made pro write_{.INF} me_{.DAT} lo_{.ACC·MASC}
 “I made him write me it.”

In (75), the embedded subject, the clitic *lo* (‘him’), moves to the higher clause and attaches to the finite ECM verb *hice* (‘I made’). In the sentence in (75), all three argument clitics are marked for object case, two for accusative and one for dative. As we will argue at length in Chapter 5, each type of structural Case should only have one corresponding feature on a verb. Thus, it should not be possible for one verb to assign accusative Case twice. This leads us to assume that there are two Case-assigning verbs in (75), the finite ECM verb and the embedded infinitive. If we follow Chomsky (2001, 2008) in assuming that Case features are properties of phase heads, then this suggests that there are two different verbal phases present above—not one—and hence two separate clauses present in the underlying structure of (75).

Finally, as we will discover later in this chapter (in section 2.9), there are binding data involving the movement of reflexive clitics in ECM/causative constructions that also imply the existence of two clauses for the relevant binding facts to apply (cf. Chomsky 1987). For now it

will suffice to point out that there are strong reasons to assume clitic climbing involves biclausal structures when the embedding verb is lexical (i.e., a main verb), such as in ECM constructions.

2.8 Islands: Barriers to Clitic Climbing

Let us now consider the main ‘islands’ that block clitic movement. A movement analysis for clitics is strongly suggested by the fact that the placement of these elements is sensitive to intervention effects. For instance, clitic climbing is not possible over *wh*-complementizers. Take a look at the data in (76) and (77):

- (76) a. No me sé [_T callar *t_{me}*].
no me I know shut up._{INF}
“I don’t know how to shut up.”
- b. *No me sé [_{CP} cómo callar *t_{me}*].
no me I know how shut up._{INF}
“I don’t know how to shut up”
(Ordóñez 2012: 435)
- c. No sé [_{CP} si comprarlo].
no I don’t know if buy._{INF} it._{ACC.MASC}
“I don’t know whether to buy it.”
- d. *No lo sé [_{CP} si comprar *t_{lo}*].
no it._{ACC.MASC} I know if buy._{INF}
“I don’t know whether to buy it.”
(Ordóñez 2012: 436)
- (77) a. No sé [_T decírtelo].

no I know say._{INF} you._{DAT} it._{ACC.MASC}

“I don’t know (how) to say it to you.”

b. No te lo sé [_T decir t_{te} t_{lo}].

no you._{DAT} it._{ACC.MASC} I know say._{INF}

“I don’t know (how) to say it to you.”

c. No sé [_{CP} qué decirte t_{qué}].

no I know what tell._{INF} you._{DAT}

“I don’t know what to tell you.”

d. *No te sé [_{CP} qué decir t_{te} t_{qué}].

no you._{DAT} I know what tell._{INF}

“I don’t know what to tell you.”

The presence of *+wh* elements *cómo* ‘how’, *si* ‘if’, ‘whether’, and *qué* ‘what’ blocks the climbing of the clitic, which is otherwise permissible. In (77d), the indirect object clitic *te* ‘you’ cannot raise over the *+wh*-DO, and is stuck in the embedded clause as an enclitic to its selecting verb *decir* ‘say’. When the DO is itself a clitic, however, with no *+wh* specification, both the DO and the IO can cliticize readily to the higher verb, as we see in (77b).

As was noted above in section 2.7 in the discussion on clitic climbing, another restriction on clitic movement is the presence of a lexically specified subject. Once again, this was first observed by Kayne (1975) and attributed to the Specified Subject Condition. Not only does this restriction apply to constructions where the main verb is a verb of perception (e.g. *ver* ‘see’, *oír* ‘hear’), but also to causative constructions. For instance, when the subject causee intervenes between the causative verb and the infinitive, the clitic cannot be extracted, as in (78a):

- (78) a. *Pedro lo hizo [a Juan leer t_{lo}]. (lo= *el libro*, ‘the book’)

Pedro him._{ACC·MASC} made to Juan read._{INF}

“Pedro made Juan read it.”

- b. *Pedro lo vio [a Juan leer t_{lo}].

Pedro him._{ACC·MASC} saw to Juan read._{INF}

“Pedro saw him read it.”

However, when the subject of the embedded clause appears post verbally, the clitic can climb:

- (79) a. Pedro lo hizo [leer a Juan $t_v t_{cl}$].²⁰

Pedro him._{ACC·MASC} made read._{INF} to Juan

“Pedro made Juan read it.”

- b. Pedro lo vio [leer a Juan $t_v t_{cl}$].

Pedro him._{ACC·MASC} saw read._{INF} to Juan

“Pedro made him read it.”

(Ordóñez 2012: 438).

When the subject of the embedded clause is a clitic, that clitic may move by itself, or both the subject clitic and the object clitic of the embedded verb may climb together, with the embedded subject clitic always above the embedded object clitic:

- (80) a. Yo le hice [t_e lavarla].

I him._{DAT} made wash._{INF} it._{ACC·FEM}

²⁰ In some varieties of Spanish, as in Mexican Spanish, the accusative clitic can climb to the higher clause of an ECM construction without an accompanying dative clitic (as in (79 a and b) (Ordóñez 2012: 438)). However, in most dialects of Spanish, the presence of the dative clitic, representing the embedded subject, is mandatory (cf. Strozer 1976: 371). In those dialects, the sentences in (79) would be, respectively, *Pedro se_i lo hizo leer a Juan_i* (Pedro made Juan read it) and *Pedro se_i lo vio leer a Juan_i* (Pedro saw Juan read it). In both cases, *se* is the dative-marked argument clitic corresponding to the embedded subject. We will derive these sentences where both embedded subject and object clitics raise to object in Chapter 5.

“I made him wash it.”

b. Yo se la hice [t_{se} lavar t_{la}].

I him._{DAT} it._{ACC-FEM} made wash._{INF}

“I made him wash it.”

(Strozer 1976: 363)

c. Lola le dejará [comerlo a Juan t_{le} t_v t_{lo}].

Lola him._{DAT} allow._{FUT} eat._{INF} it._{ACC-MASC} to Juan

“Lola will allow Juan to eat it.”

d. Lola se lo dejará [comer a Juan t_{se} t_v t_{lo}].

Lola him._{DAT} it._{ACC-MASC} allow._{FUT} eat._{INF} to Juan

“Lola will allow Juan to eat it.”

(Strozer 1976: 36)

(81) a. Ella me vio [t_{me} hacerlo].

she me._{DAT} saw do._{INF} it._{ACC-MASC}

“She saw me do it.”

b. Ella me lo vio [t_{me} hacer t_{lo}].

she me._{DAT} it._{ACC-FEM} saw do._{INF}

“S/he saw me do it.”

(Parodi, p.c.)

A third intervening element that blocks clitic movement is negation, specifically clausal negation, as in the examples in (82):

a. No lo hago t_{lo} .

no *it*._{ACC·MASC} I do

“I don’t do it.”

b. *Lo no hago *t_{lo}*.

it._{ACC·MASC} no I do

“I don’t do it.”

c. Ella intenta [_{CP} no leerlo].

she intends no read._{INF} *it*._{ACC·MASC}

“She intends not to read it.”

d. *Ella lo intenta [_{CP} no leer *t_{lo}*].

she *it*._{ACC·MASC} intends no read._{INF}

“She intends not to read it.”

(Ordóñez 2012: 436).

In the examples in (82), the negative operator *no* functions as an intervener that blocks movement. In the analysis in Chapter 5, this will be related to the position that negative operators occupy in the syntax. When no negative operator is present, the embedded clause can be argued to lack CP, and movement of the clitic to the higher clause follows without posing any problems to conditions on impenetrability (e.g., the Phase Impenetrability Condition).

Fourthly, clitic climbing is not permitted from a tensed clause. This was originally attributed to the Tensed S condition (cf. Chomsky 1973, Kayne 1975, Quicoli 1976):

(82) a. Yo deseaba [que Pepe hubiera deseado hacerlo].

I wanted that Pepe had wanted do._{INF} *it*._{ACC·MASC}

“I wanted Pepe to have wanted to do it.”

b. Yo deseaba que [Pepe lo hubiera deseado hacer t_{cl}].

I wanted that Pepe $it_{ACC\cdot MASC}$ had wanted do_{INF}

“I wanted Pepe to have wanted to do it.”

c. *Yo lo deseaba [que Pepe hubiera deseado hacer t_{cl}].

I $it_{ACC\cdot MASC}$ wanted that Pepe had wanted do_{INF}

‘I wanted Pepe to have wanted to do it’

(Strozer 1976: 286).

Fifthly and finally, clitic movement is forbidden to or above intermediate verb forms that subcategorize argument clitics of their own. In (83), the infinitive *seguir* is a main verb that means ‘follow’, not to be confused with its auxiliary homophone which means ‘continue.’ Consequently, the clitic *me* in the examples in (83) originates as an argument of *seguir*:

(83) a. Ella deseaba seguirme gritándolas. (*las*= *las groserías*, ‘the obscenities’)

she wanted follow. $_{INF}$ me shouting them. $_{ACC\cdot FEM}$

“She wanted to follow me shouting them.”

b. *Ella deseaba seguírmelo gritando t_{las}

she wanted follow. $_{INF}$ me them. $_{ACC\cdot FEM}$ shouting

“She wanted to follow me shouting them.”

c. Ella me deseaba seguir t_{me} gritándolas.

she me wanted follow. $_{INF}$ shouting them. $_{ACC\cdot FEM}$

“She wanted to follow me shouting them.”

d. *Ella me las deseaba seguir t_{me} gritando t_{las} .

she me them._{ACC-FEM} wanted follow._{INF} shouting

“She wanted to follow me shouting them.”

(Strozer 1976: 283)

Note that in (83c) the clitic *me* selected by *seguir* ‘follow’ does have the option to climb to the matrix verb, but *las* of *gritar* ‘shout’ cannot climb any higher (as in (83d)). This is reflective of the fact that the clitics in this reading are selected by different verbs, since, as we saw in examples above, object clitics subcategorized by the same verb must always move together. Under the alternative ‘continue’ reading of *seguir*, listed in Table 2.3, both (83b) and (83d) would be grammatical. On the other hand, examples (83a) and (83c) would be bad with the auxiliary reading of *seguir*, as the clitic *me* in that case would originate with *lo* as internal arguments of *gritar*. In Table 2.5 we summarize the barriers to clitic climbing:

Table 2.5: Barriers to Clitic Climbing

Barrier	Example
Lexically Specified Subject	*Pedro lo hizo a Juan leer.
+wh-Element	*No te sé qué decir.
Negation	*Lo intentaba no comer.
+Finite T	*Yo lo quería que Pepe hubiera querido hacer.
Intervening Clitics	*Me lo quería seguir gritando.

One of the main goals of the analysis in Chapter 5 is to provide an explanatory account of conditions that regulate the movement of clitics, including the intervention effects listed above.

2.9 The ‘Other’ Clitics of Spanish: Speaker Datives and *SE* Constructions

Beyond the determiner-like accusative and dative clitics that we have analyzed to this point, we also find other clitics in Spanish whose behavior differs crucially from the so-called argument clitics. These include a class of ethical dative clitics called ‘speaker’ clitics, as well as the variety of impersonal, passive, and aspectual clitics that fall under the classificatory umbrella of *SE* constructions (cf. Mendikoetxea 2012). Our analysis is not concerned with such clitics, as there are good reasons to consider them non-argument morphology, instead of true pronominals. First consider the speaker clitics. Strozer coined the term ‘speaker’ to distinguish a subclass of ethical datives that cannot be doubled by a stressed noun phrase associate. Consider the difference between *me* clitics in the sentences in (84):

- (84) a. Luis me cantó una canción (a mí).
Luis me._{DAT} sang a song to me
“Luis sang me a song.”
- b. Luis me le_i cantó una canción (al niño_i) (*a mí)
Luis me._{SPK} him._{DAT} sang a song (to the boy) (*to me)
“Luis sang the boy a song on/for me.”

Observe that the ethical dative *me* in (a) can be doubled by a strong pronoun, while the same morphological form in (b) cannot be doubled. The difference is that the *me* clitic in (84b) is a ‘speaker’ clitic, while the *me* in (84a) is a regular dative indirect object clitic. According to Strozer, speaker clitics represent the speaker or ‘addressor’ of the sentence, and they always appear together with an indirect object clitic, such as *le* in (84b). They are not relatable by the sentence grammar to either a subject or an object DP (unlike doubles and anaphors), but they are coreferential with the person uttering the sentence. The inability of these elements to project a

double sets them apart from other ethical dative clitics that can be doubled, as well as other types of dative ‘goals’ that have already been discussed, and that were analyzed as dative arguments.

Consider the following sentences in (85)-(87) in which speaker clitics can appear:

- (85) Me le_i dieron un helado (al niño_i) (*a mí)
me.SPK him.DAT gave an ice cream to the boy to me
“They gave the boy an ice cream on/for me.”
- (86) Me le_i escribieron una carta llena de elogios (a él_i) (*a mí)
me.SPK him.DAT they wrote a letter full of praise to him to me
“They wrote him a letter full of praise for me.”
- (87) Me le_i premiaron el dibujo (a él_i) (*a mí)
me.SPK him.DAT they awarded the drawing to him to me
“They awarded his drawing a prize on me.”

One of the crucial diagnostic tests for determining if a pronoun is an argument hinges on its ability to be replaced or appear doubled a full noun phrase. As speaker clitics have no capacity to double, and are only able to corefer, we consider them morphological clitics. This is also a desirable assumption in a theoretical framework where each verb can only subcategorize one thematic dative argument, as it may only subcategorize one thematic accusative argument. Allowing verbs to subcategorize more than one thematic dative argument diminishes the symmetry between internal arguments.²¹ Furthermore, there is empirical evidence from ECM constructions, which we will consider in detail in Chapter 4, that suggests that there is only one

²¹ Because of the possibility of clitic doubling, and our adoption of the big DP hypothesis for generating clitics and their doubles together (cf. Uriagereka 1995), we suggest that even though verbs can subcategorize multiple DPs per Case slot, these nominals must share the same theta-role, hence the desideratum of ‘one thematic argument’ mentioned above.

dative argument allowed per agreeing verb, based on the fact that only one dative-marked clitic can raise to object position in those constructions (i.e. the clitic that stands for the embedded subject). Although embedded DO objects can move up with verb inversion, dative objects cannot move up to the finite verb in ECM sentences, and we will argue that this is due to the presence of the embedded subject clitic, which mandatorily raises to object position in most dialects of Spanish, and is valued with abstract dative Case. Consequently, there are good reasons to believe that verbs cannot value multiple arguments with structural dative Case, and thus speaker clitics should be considered, at the theoretical level, as Caseless morphological affixes generated in a functional/inflectional head²².

The same conclusion can be applied to non-anaphoric *se* clitics in Spanish. Below in (858) is a complete inventory of the relevant constructions:

- (88) a. Se observa(n) cambios en la economía.²³ *impersonal/passive*
SE observe changes in the economy
“One observes changes in the economy.”/
“Changes are observed in the economy.”
- b. Las casas prefabricadas se construyen fácilmente. *middle*
the houses prefabricated SE construct easily
“Prefabricated houses are easily built.”
- c. Ana se durmió. *pseudo-reflexive*
Ana SE slept

²² We thus distinguish the morphological dative case-marking on speaker clitics from the possession of abstract Case.

²³ In (85a), we have two structures, depending on whether there is verbal agreement with the internal argument or not. The agreeing construction is an example of ‘passive’ *se*, while the non-agreeing construction is ‘impersonal’ *se*. The latter is interpreted as having an arbitrary subject, like *one* or *people* in English (Mendikoetxea 2012: 481).

“Ana fell asleep”

d. El cristal se rompió.

unaccusative/inchoative

the glass SE broke

“The glass broke.”

e. Juan se comió las manzanas.

aspectual/telic

Juan SE ate the apples

“Juan ate up the apples.”

f. Juan se fue.

aspectual

Juan SE went

“Juan went away.”

(Mendikoetxea 2012: 478)

In each of the cases above, the clitic *se* cannot be related by sentential syntax to a conceivable argument, except for ‘impersonal’ *se*, which may be doubled by an arbitrary subject such as *uno* ‘one’ (e.g. *Uno se aprende este deporte en cinco días*, ‘One SE learns this sport in five days.’) This *se* is the ‘subject clitic’ of Spanish—which some researchers have analyzed as an anaphor (e.g., Dobrovie-Sorin 1998, Rivero 2002, Teomiro 2010) while others view it as an agreement clitic (e.g., Belletti 1982, Otero 1986, Mendikoetxea 1992, 2008, among others). As the present work is focused primarily on the derivation of accusative and dative-marked object clitics, we will leave this question aside, perhaps to pick it up in future research. The rest of the *se* clitics in (88) clearly lack abstract Case. The only *se* clitic relevant to the present analysis is the anaphoric, and hence truly reflexive *se*. Observe how Spanish permits homophonous constructions in (89) in which the pseudo and true reflexive *se* alternate:

- (89) a. Ana se durmió (*a sí misma)

Ana SE slept to herself

“Ana fell asleep.”

- b. Ana se durmió (a sí misma)

Ana SE._{REFL} slept to herself

“Ana put herself to sleep”

The reflexive clitic in (89b) is a true reflexive. We assume that reflexive clitics, both DOs and IOs, are generated in argument position and move via agreement with probes that can delete their Case features. They are also subject to Binding Theory (Quicoli 1976, Chomsky 1987) (see examples (90) and (91) below). Hence, in addition to phi- and Case features, reflexive clitics may enter the derivation carrying +anaphor features that allow them to continue moving even after they have deleted Case. This would be relevant in agreement approaches to binding theory (e.g., Reuland 2001). In such an account, it is speculated that the reflexive object clitic moves from its Case position to T, to derive agreement with its DP antecedent in [Spec, TP]. We will not delve into the specifics of Binding Theory in this work, nor will we consider recent attempts to reduce binding to the operation of Agree. Nevertheless, it should be stressed that reflexive clitics can climb, and must climb, when generated in a clause that does not contain their antecedent (90). Binding theory prevents them in most dialects, however, from raising to object when their antecedent is in the embedded clause (91):

- (90) a. Juan se_i hizo [_T afeitar por el barbero t_v t_{se}]

Juan SE._{REFL} made shave._{INF} by the barber

“Juan made the barber shave him.”

b. *Juan_i hizo [_T afeitarse_i por el barbero t_v t_{se}]

Juan made shave._{INF} SE._{REFL} by the barber

“Juan made the barber shave him.”

(Chomsky 1987: 23)

(91) a. Juan hizo [afeitarse_i a los muchachos_i t_v t_{se}]

Juan made shave._{INF} SE._{REFL} to the boys

“Juan made the boys shave themselves.”

b. *Juan se_i hizo [afeitar a los muchachos_i t_v t_{se}]²⁴

Juan SE._{REFL} made shave._{INF} to the boys

“Juan made the boys shave themselves.”

(Chomsky 1987: 19)

The binding data above, which was originally discovered in French by Richard Kayne (1976) and in Portuguese by Carlos Quicoli (1976) and then later translated to Spanish for use in Chomsky’s *Managua Lectures* (1987), presents another piece of evidence in favor of clitic movement, as well as the biclausality of clitic climbing in causatives. The subject of the causative verb must be in a higher clause to bind the reflexive-marked pronoun in (90a), and to avoid binding the anaphor in (91b). Furthermore, and crucially, the clitic elements in the examples in (90) and (91) must start in the relevant argument positions to be bound in the first place, *pace* base generation accounts that generate clitics in non-argument positions.

²⁴ In some dialects of Spanish, it appears that speakers can lift the anaphoric clitic into the higher clause, and hence (91b) would be acceptable to them (p.c. Claudia Parodi). In these dialects, we speculate that although binding of the reflexive clitic takes place in the lower clause, it can nevertheless move onto the higher finite verb to check some feature(s). See the analysis in Chapter 5 where we postulate that clitic movement to the embedding verb of ECM/causative structures is motivated by the existence of a +affix feature on finite verbs that must be locally valued/deleted via incorporation the clitic, which is itself a syntactic affix. As the +affix feature on a verb has no semantic value, it must be deleted in the narrow syntax, before being sent to LF.

Returning to the pair of reflexive examples (89), it should be noted that the clitic in (89a) is not anaphoric and, consequently, cannot not be doubled. This ‘pseudo-reflexive’ clitic is referred to as an ‘inherent’ reflexive by Strozer, while the verbs that select these non-referring reflexives are commonly referred to as ‘pronominal verbs’ (Strozer 1976: 241). Many such verbs in Spanish cannot appear without the morphologically reflexive clitic. The pronominal verb class includes *suicidarse* ‘commit suicide,’ *desmayarse* ‘faint,’ *arrepentirse (de)* ‘be sorry about,’ *quejarse (de)* ‘complain about,’ *atreverse a* ‘dare to,’ *jactarse de* ‘boast about.’ Although such verbs never appear without their *se* clitic, there are other pronominal verbs with non-clitic homophones, such as *ir(se)*, ‘go (away),’ *volar(se)*, ‘fly (away),’ *marchar(se)* ‘go (away),’ *llevarse* ‘take (away)’. Finally, there is a much smaller group of pronominal verbs whose homophones differ completely in meaning, such as *acordar* ‘agree’ and *acordarse (de)* ‘remember,’ as well as *empeñar* ‘pawn’ and *empeñarse* ‘persist in’ (Strozer 1976: 245).

Although a detailed analysis of the syntactic and semantic properties of non-reflexive *se* clitics is beyond the scope of the present work, we would be remiss not to point out that all *se* forms must be pronounced before other dative and accusative-marked clitics. This morphological generalization relates to Perlmutter’s filter (1971) on the supposedly universal order of clitics within a cluster sequence. His filter is summarized below in (92a), with its grammatical output in (92b) (bold), and the forms it predicts as bad in (92c) (starred):

- (92) a. *se-II-I-III (DAT)-III (ACC)-III*
- i. For sequences of non-reflexive 3rd person clitics, dative precedes accusative.
 - ii. Non-3rd person clitics precede 3rd person clitics.
 - iii. *Se* precedes all other clitics.

iv. Sequences of phonetically identical clitics are excluded.

b. **se me/se nos/se te/se os/se le/se lo/me lo/te lo/te me/etc.**

c. *me se/ *me te/*le me/*le te/*se se/*lo lo/*le le/etc.

The combinations in (92c) are bad for most native speakers, but, according to various authors, have been attested to in dialectal variation, as in the contrast between the filter-predicted order in (93a) and dialectally-attested (93b):

(93) a. Se me escapa. (Standard Spanish)

SE me.DAT escapes

“It’s getting away from me.”

b. Me se escapa. (Dialect of Spain)

me.DAT se escapes

“It’s getting away from me.”

(Ordóñez 2012: 446)

A final interesting generalization regarding *se* constructions and clitic ordering is the observation made by Cuervo (2013) that ‘spurious’ *se* cannot occupy the position of genuine *se*. Thus, in a clitic cluster of three clitics, spurious *se* cannot be pronounced before a reflexive. In other words, the response in (94) is markedly bad (where *llevarse* ‘steal, take away’ is an inherent reflexive):

(94) –Me le llevé el auto (a Emilio)

me.REFL him.DAT I took the car to Emilio

“I took the car from him for myself.”

--*¿En serio, se te lo llevaste?

in seriousness, him.DAT you.REFL it.ACC.MASC you took

“You really took it from him for yourself?”

(Cuervo 2013: 198)

Cuervo claims that all speakers react negatively to the response in (94). This is because of the fact that spurious *se* (referring to Emilio) is above the reflexive *te*, and hence spurious *se* and the accusative clitic are separated. Cuervo attests to a possible repair strategy for the impossible string in (95), by moving *te* in front of *se* (*pace* the ordering prediction of Perlmutter’s filter):

(95) ? ¿En serio, te se lo llevaste? (Dialectal Spanish)

in seriousness you.REFL him.DAT it.ACC.MASC you took

“You really took it from him for yourself?”

(Cuervo 2013: 199)

Of course, three clitics in a cluster would be universally accepted in such a scenario if the speaker, instead of having stolen someone else’s car, was the person who had his car stolen by someone else. In other words, imagine if the roles were reversed, and the inherent reflexive is marked for 3rd person, as in (96):

(96) Se me lo llevó. (lo= *el auto* ‘the car’)

SE.REFL me.DAT it.ACC.MASC took

“He took it away from me.”

We will save our explanation of the underlying phenomenon responsible for the ungrammaticality in (94) for the next chapter, in our discussion of dialectal variation with clitics. For the moment it will suffice to point out that there appears to be a restriction in separating the argument clitics in a cluster when they have already fused together syntactically.

2.10 Concluding Remarks

We hope that the data reviewed in this introductory chapter sufficiently demonstrates the need for a movement analysis of object argument clitics in many dialects of Spanish, including standard dialects spoken outside of the Río de la Plata area. First, recall that DO and IO clitics in these dialects are the mandatory elements in the types of constructions that can take them. These clitics may appear doubled by stressed noun phrases, but in every relevant case, the double is the optional element, while the clitic is the mandatory element. This is a significant fact for a language such as Spanish, which only permits null objects in non-specific bare and partitive nominal contexts (e.g., *Dinero, no tengo* ‘Money, I don’t have any’). Not only are direct and indirect objects clitics mandatory in Spanish whenever possible, but their doubles must be introduced via a prepositional Case-phrase (KP) to be licit, once again suggesting that clitics in these dialects absorb argumental Case from licensing verbs.

Furthermore, direct object clitics overlap morphologically and semantically with definite articles in Spanish, leading us to conclude that these elements are of the category determiner, and as such head their own nominal phrase in the syntax. Indirect object clitics, which are the mandatory dative elements in Spanish double object constructions, show a similar diachronic evolution from Latin as accusative clitics—both developed from previously stressed pronouns in Latin. And IO clitics, like DO clitics, have been shown to be sensitive to intervention effects, and cannot move out of islands, such as *wh*-islands (e.g., **No te sé qué decir* (‘I don’t know what to tell you’)). This strongly suggests that IO clitics are of the same class as DO clitics in standard dialects, nominals. Base Generation accounts which class DO and/or IO clitics as morphological affixes generated on the verb struggle to explain said intervention effects.

Base generation accounts are also problematic in that they cannot principally distinguish argument object clitics (the ones that can be related by the syntax to full DP doubles) and non-argument clitics, such as speaker datives and inherent reflexives discussed by Strozer (1976), which cannot be doubled by a referring pronoun, as we saw in section 2.9.

Finally, if morphological constraints are solely responsible for object clitic placement, as base generation suggests, then it is not possible to explain why inherent reflexives cannot be placed in between argument clitics (see the the Cuervo (2013) example in (94) above. As Cuervo observed, when there are three clitics in a cluster in Spanish, the inherent reflexive clitic in (94) cannot be placed between the two argument object clitics, which were presumably merged together syntactically at an earlier step of the derivation, before insertion of the morpheme clitic *se*. This recent discovery lends further support to the movement hypothesis for IO and DO clitics, specifically movement of terminal elements (i.e., heads).²⁵

However, first let us examine dialectal variation as it relates to clitics in Spanish, since examples from dialectal variation in Spanish have been the main catalyst for popular base generation accounts in recent years.

²⁵ See Chapter 4 for arguments linking cliticization to head movement.

CHAPTER 3

Dialectal Variation with Spanish Clitics

3.1 A Challenge to the Movement Hypothesis?

In this chapter, we will take a brief tour of dialectal variation with clitics found throughout the Spanish-speaking world. The data that we reviewed in Chapter 1 can be classified as belonging to ‘Standard Spanish’ (cf. Ormazabal and Romero 2013). The Standard, although in part an idealization, nevertheless corresponds to rules that most native speakers of Spanish consciously or unconsciously conform to in their use of clitic pronouns. In that sense, the Standard is a real entity that exists in the minds of speakers. It also happens to be the set of rules that are enumerated in modern traditional (i.e., descriptive) grammars such as *La nueva gramática de la lengua española* (2011). This comprehensive grammar is compiled by the *Real academia española* (‘Royal Spanish Academy’), the official institution responsible for ‘overseeing’ the Spanish language as it is spoken throughout the world. The types of rules we reviewed in Chapter 1 follow the descriptions and prescriptions codified in the Royal Academy’s magnum opus on Spanish grammar. The Royal Spanish Grammar, which ultimately emanates from the *Real academia* in Spain (with satellite institutions in other countries) attempts to

encompass a pan-Hispanic set of norms that more or less represent the knowledge of educated native speakers in the entire *mundo hispanohablante*.

The forms we will review in this chapter, however, deviate from the pan-Hispanic norms in various ways. Specifically, we will discuss dialects of Spanish in which (1) dative clitic forms are used for animate direct objects, (2) accusative clitic forms are used for animate indirect objects, (3) singular direct object clitics are pluralized via association with actually plural indirect objects, (4) direct object clitics permit non-pronominal doubles, (5) direct object clitics that do not obey Kayne's Generalization and that permit doubles that don't agree in phi-features, and (6) the same clitic appears enclitically and proclitically in the same sentence.

Respectively then, the main dialects we will consider include (1) *leísmo*, (2) *laísmo*, and *loísmo* of central and northern Spain, (3), the 'parasitic plurals' of Mexico, (4) DO clitic doubling in the dialects of the Río de la Plata region (a.k.a., *Porteño* Spanish), (5) DO clitic doubling in Andean and Los Angeles Vernacular Spanish, and finally (6) clitic duplication varieties in Chile and other Southern Cone countries. In the literature on clitics and clitic doubling, 'dialectal variation' is usually cited in favor of Base Generation accounts in which clitics do not move, and are instead generated in functional heads where they surface proclitically. This is in large part due to the major discovery of Suñer (1988) that among certain speakers of *Porteño* Spanish, Kayne's Generalization does not hold (i.e., clitics can be doubled without an accompanying Case marker). However, as we will see in the following analysis, a careful inspection of the dialectal facts points to a more complex reality than is often acknowledged in the recent wholesale abandonment of Kayne's Generalization. That is, while in some dialects clitics have undoubtedly lost their status as determiner phrase arguments, other dialects appear to entail overt copying (and hence movement in the Copy Theory) of both

accusative and dative clitics. Thus, dialectal variation, instead of constituting a formidable challenge to the theory outlined in this work, actually provides some of the strongest empirical arguments in favor of the movement approach.

3.2 *Leísmo* and the ‘Parasitic Plurals’ Connection

The first major source of dialectal variation to consider includes the so-called *leísta* dialects of central and northern Spain. *Leísmo* is a phenomenon in which the 3rd person dative clitic is used for animate direct objects, while the normal accusative form is used for inanimate direct objects:

- (1) a. Le vi a él.
to him.DAT I saw him
“I saw him.”
- b. Ese árbol, sí lo veo.
that tree, yes it.ACC.MASC I see
“That tree, yes I see it.”

In the ‘standard’ *leísta* dialect of Madrid, also known as Central Peninsular, only singular, animate, masculine direct objects are marked datively as *le* (Fernández-Ordóñez 1999: 1). Plural masculine, as well as feminine direct objects retain their regular accusative forms. Furthermore, in this dialect, as in the pan-Hispanic standard, DO clitics, even the ones that get dativized, cannot be doubled by a non-pronoun in the same intonational contour. The facts in (2) summarize the relevant distinctions made in Central Peninsular (‘Standard’) *leísmo*:

- (2) a. Lo vi. (lo=*el libro* ‘the book’)
it.ACC.MASC I saw

“I saw it.”

b. Le vi a él.

him._{DAT} I saw to him

“I saw him.”

c. Le vi (*a Juan)

him._{DAT} I saw to Juan

“I saw Juan.”

d. Los vi (a ellos)

them._{ACC.MASC} I saw to them

“I saw them.”

e. La vi (a ella)

her._{ACC.FEM} I saw to her

“I saw her.”

f. Las vi (a ellas)

them._{ACC.PLUR.FEM} I saw to them

“I saw them.”

However, in another, less common variant, known as Basque *leísmo* (i.e., *leísmo* spoken in the Basque Country of northern Spain) all animate direct objects are marked datively, while inanimates remain accusatively marked (Romero and Ormazabal 2013: 327). In Basque *leísmo*, the DO's that get marked datively can also be doubled freely, like all indirect objects in Standard Spanish. Accusative-marked objects in this dialect, however, forbid DP doubling:

(3) a. Lo vi (*el libro).

it._{ACC.MASC} I saw (the book)

“I saw it.”

b. Le vi (al niño/ a la niña)

him/her._{DAT} I saw to the boy/to the girl

“I saw the boy/the girl”

(Romero and Ormazabal 2013: 316)

Furthermore, in Basque *leísmo*, the DO ‘datives’ can, interestingly, double with all of the same types of nouns as IO clitics, including negatively quantified DPs, while inanimate DO’s cannot:

(4) a. *Ningún libro lo han visto en la universidad.

none book it._{ACC-MASC} they have seen in the university

“No book have they seen in the university”

b. No le han visto a ningún estudiante en la universidad.

no them._{DAT} they have seen none student in the university

“They haven’t seen any student in the university.”

(Romero and Ormazabal 2013: 317)

Therefore, in Basque *leísmo*, direct object clitics marked as *le* have the syntactic doubling capabilities of indirect object clitics in all dialects, and the same interpretive restrictions as them as well, while accusative-marked inanimates retain the normal syntactic-semantic properties of regular DO clitics. Despite these morphological deviations from Standard Spanish, we assume that not much is happening here in terms of the underlying syntax. This hunch is confirmed by ‘spurious *se*’ constructions. As we already discussed in footnotes in Chapter 1, spurious *se* (or as it is known in Spanish, *se variante de le*) arises from a morphological filter that causes the 3rd person dative clitic to be spelled out as an opaque form when it is directly followed by a 3rd person accusative clitic (e.g., *Se lo presto* (‘I loan him it.’)).

In the dialects of *leísmo*, as in all other dialects, spurious *se* constructions spell out the direct object clitic as *lo*; in other words, the DO clitic cannot be pronounced as *le* in an IO DO cluster, even when it is a singular masculine animate. These facts are highlighted in (95):

- (5) a. Le llevé a tu hijo a casa.
him._{DAT} I brought your son to home
“I brought your son home”
- b. Te (*le) llevé a casa.
you._{DAT} him._{DAT} I brought to house
“I brought you him home.”
- c. Te lo llevé a casa.
you._{DAT} him._{ACC-MASC} I brought to house
“I brought you him home.”

(Romero and Ormazabal 2013: 317)

It appears then that the underlying form of the DO *le* in these dialects is actually *lo*, which is then assigned dative Case morphology at a certain point in the derivation. When the IO clitic is present, the morphology is blocked. In order to block it though, the dative clitic must be in an appropriate structural position to act as an intervener. Further suggestion of this last point comes from another interesting dialectal variant involving two consecutive 3rd person clitics, the so-called ‘parasitic plurals’ phenomenon of Mexican Spanish. In parasitic plurals, a plural 3rd person dative clitic bleeds number agreement to the 3rd person accusative clitic next to it, even if the DO is singular (Rivarola 1985). We can see parasitic plurals at work in (38):

- (6) El libro, a ellos, ¿quién se los prestó?
the book, to them, who them._{DAT} it._{ACC.PLUR.MASC} lent

“The book, to them, who lent it to them?”

(Ordóñez 2012: 444)

Cuervo (2013: 201) observes that the transmission of plurality here is only possible in a very local environment, and we propose that the structure introduced in Figure 1.2 (p.6) explains how this transmission might occur, after D_{le} is incorporated into the left edge of the v head complex, adjacent on the edge to D_{lo} . After this incorporation takes place, the structure is sent to Phonological Form (PF). Since the syntax has incorporated one clitic into the other, it is conceivable that upon Transfer they occupy the same position in a morphological template (Cuervo 2013: 201), and are read by the morphology as a single item at PF. This would in turn provide an explanation of the ungrammaticality in (7), introduced at the end of Chapter 1:

(7) –Me le llevé el auto (a Emilio)

me._{REFL} him._{DAT} I took the car to Emilio

“I took the car from him for myself.”

--*¿En serio, se te lo llevaste?

in seriousness, him._{DAT} you._{REFL} it._{ACC-MASC} you took

“You really took it from him for yourself?”

(Cuervo 2013: 198)

If the dative and accusative clitics are both merged in v , then an intervening element (such as an inherent reflexive clitic base generated in an inflectional head, possibly in the T-field) could not be inserted between them. This is articulated as a principle of grammar in Chomsky’s No Tampering Condition (NTC), stated in (8) (cf. Narita 2011: 23):

(8) No elements introduced by syntax are deleted or modified in the course of linguistic derivation.

In the present analysis, it is assumed that the NTC applies to the product of head movement, as it applies to other types of mergers involving maximal elements.¹ This can be visualized in Figure 3.1, where we see that there is no possible node for the inherent clitic to insert itself between the dative and accusative arguments.

Figure 3.1: Three Clitic Cluster—No Tampering with IO-DO Merger

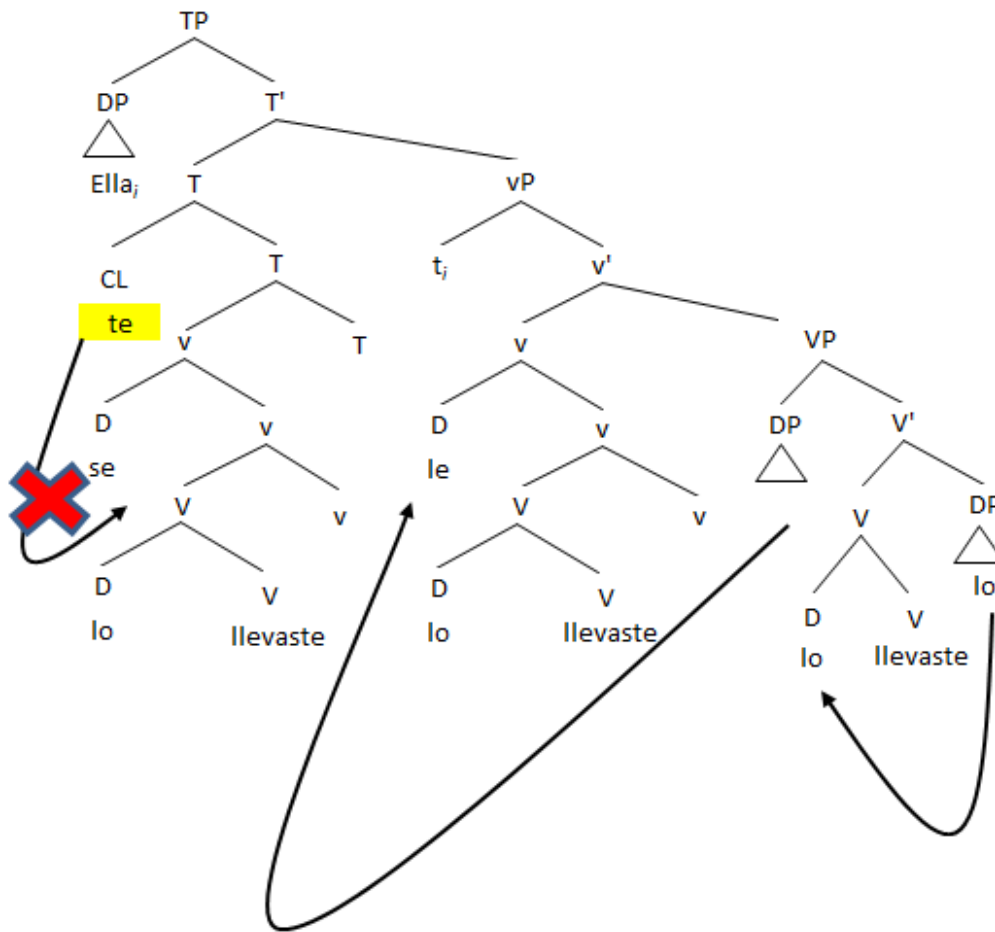

Observe that the derivation sketched in Figure 3.1 above is consistent with the fact that a non-argument reflexive clitic cannot be sandwiched in between arguments previously merged

¹ See Chapter 4 of the present work for a detailed review of Roberts’s (2010a) arguments in favor of completely assimilating syntactic head movement to XP-movement.

together in the v-phase. Furthermore, this diagram correctly predicts the dialectal variant on clitic clustering cited in Cuervo (2013), in (9):

- (9) ? ¿En serio, te se lo llevaste? (Dialectal Spanish)
in seriousness you.REFL him.DAT it.ACC.MASC you took
“You really took it from him for yourself?”
(Cuervo 2013: 199)

Although the sentence in (9) goes against the prediction of Perlmutter’s filter on order in clitic clusters, and may not be acceptable for native speakers of standard variants of Spanish, it is a dialectal variant that has been demonstrated in the literature to be a possible sentence—unlike the universally unacceptable order where a reflexive violates the NTC (in 7). In summary, we can tell that the morphological processes that yield *leísmo* do not alter or disrupt the core syntactic mechanisms responsible for head movement of clitics and probe-goal dependencies that value/delete uninterpretable features on lexical items.

3.3 *Leísmo real v. Leísmo aparente*

Before we continue on our tour of dialectal variation, we feel compelled to stop here and point out an important (and potentially confusing) distinction between the phenomenon of ‘real’ or ‘Peninsular’ *leísmo* versus *leísmo aparente* (apparent *leísmo*). In modern times, real *leísmo* is observed predominantly in central and northern Spain.² As we explained above, in these spoken dialects transitive predicates regularly spell out animate direct objects with dative morphology. This type of *leísmo* is still present among a tiny fraction of speakers in Latin America (Fernández-Ordóñez 1999: 5), but is far less common in that region than more general forms of

² However, as Parodi et al. (2012) point out, real *leísmo* was extended throughout Latin America during colonial times. Real *leísmo* can still be found on that continent among speakers with a small class of verbs, which we discuss below.

apparent leísmo, which include the following: 1) homophonous verbs that alternate in the choice of accusative and dative-marked objects, 2) *leísmo* associated with formal discourse registers, to show deference and respect (*leísmo de cortesía*), and 3) *leísmo* used to refer to animate masculine singular antecedents in academic and formal writing (*leísmo culto*). The first type of *leísmo* found outside of north-central Spain (i.e., *zonas que distinguen el caso* ('regions that distinguish case')) depends on the types of predicates employed—in these sentences, the choice of accusative or dative pronoun changes the underlying type of structure being generated. The first relevant alternation of this kind is between transitive and unaccusative predicates that take verbs of emotion (*verbos de afección*). To convey the agency of the subject's action, accusative clitics are used to mark objects in transitive structures as in the (a) sentences below. On the other hand, when the subject is not construed as an agent, the dative clitic is often used, rendering the verbal predicate unaccusative, like in the (b) sentences:

- (10) a. A las trabajadoras las inquietaron inútilmente.
to the workers, them._{ACC-FEM} they worried pointlessly
“They worried the workers pointlessly.”
- b. A Pedro le inquieta que los policías vendan heroína.
to Pedro him._{DAT} worries that the police._{plur} sell heroine
“It worries Pedro that the cops sell heroine.”
- (11) a. A mi hijo lo asustó aquel perro.
to my son him._{ACC-MASC} scared that dog
“That dog scared my son.”
- b. A mi hijo le asustan los truenos.
to my son him._{DAT} scared the thunder._{plur}

“The thunder scared my son.”

- (12) a. Aquellos amigos lo interesaron en la política.

those friends him._{ACC·MASC} interested in the politics.*sing*

“Those friends got him interested in politics.”

- b. A Juan le interesa la política.

to Juan him._{DAT} interests the politics.*sing*

“Politics interest Juan.”

- (13) a. María la preocupó con la mala noticia.

to María her._{ACC·FEM} worried with the bad news.*sing*

“María worried her with the bad news.”

- b. La mala noticia le preocupa a María día y noche.

the bad news.*sing* her._{DAT} worries to María day and night

“The bad news worried María day and night.”

(Fernández-Ordóñez: 1999: 7)

In addition to the degree of agency of subjects, another factor that influences this accusative/dative alternation in non-*leísta* dialects is verbal aspect (cf. Parodi 1991). Accusative clitics are usually associated with verbs that denote perfect aspect, while dative clitics are associated with events construed as having imperfect aspect, as in the following:

- (14) a. Su amiga la decepcionó cuando no vino al cumpleaños.

her friend her._{ACC·FEM} deceived when no came to the birthday

“Her friend disappointed her when she didn’t come to her birthday.”

- b. A Jesús nunca le decepciona su amiga María.

to Jesús never him._{DAT} disappoint his friend María

“Jesús never disappoints his friend María.”

c. Su jefe consiguió sorprenderla más que cualquier otro compañero.

her boss managed to surprise her._{ACC-FEM} more than any other companion

“Her boss managed to surprise her more than any other coworker.”

d. Siempre le sorprende su buena suerte a Jesús..

always him._{DAT} surprises his good luck to Jesús

“Jesús is always surprised by his good luck.”

(Fernández-Ordóñez 1999: 7)

In the sentences in (14), the accusative clitic is associated with perfective, dynamic events, while the dative clitic conveys stative, imperfective event readings. The third and final factor that can provoke an alternation between the use of accusative and dative clitics emerges in causative constructions. As has been well-attested in the literature, (cf. Strozer 1976, Parodi 1991, Fernández-Ordóñez 1999) the choice of *le* vs. *lo* for causee in otherwise identical structures changes the interpretation of the sentence. Take for instance the alternation in (15):

(15) a. Le mandé traer el libro.

him._{DAT} I commanded bring._{INF} the book

“I ordered him to bring the book.”

b. Lo mandé traer el libro.

him._{ACC-MASC} I commanded bring._{INF} the book

“I ordered him to bring the book.”

According to Parodi (1991), these causatives are different with respect to affectedness, or the degree to which the matrix subject affects the behavior of the object controller clitic. In the sentence with the accusative-marked clitic, the action of the causee is more directly affected by

the command. In other words, the person giving the order is directly causing the other person to bring the book by the mere act of giving the order. In the dative sentence, on the other hand, the causal relationship between ordering and bringing is less direct—for instance, the command has created the general conditions for the book to be brought, but it is not necessarily the ultimate cause of the bringing event. The difference between these readings is more evident if we were to replace the verb *mandar* ‘order’ above with the verb *hacer* ‘make’, ‘have’—for causative constructions. Strozer equates the accusative clitic with the agentive meaning ‘make’ and the dative form with the less agentive ‘have’, as in the contrast in (16):

- (16) a. Yo le hice lavar la camisa.
I him._{DAT} had wash._{INF} the shirt
“I had him wash the shirt.”
- b. Yo lo hice lavar la camisa.
I him._{ACC·MASC} made wash._{INF} the shirt
“I made him wash the shirt.”
- (Strozer 1976: 363)

This is related to the first alternation we discussed above in which accusative pronouns were associated with greater agency on the part of the subject than dative pronouns. In those sentences, the alternations involved different types of predicates (*lo*= transitive predicate/ *le*= unaccusative predicate). The sentences in (16), on the other hand, share the same underlying structure, and the accusative/dative distinction is thus purely morphological. We can further motivate this claim with causatives by examining spurious *se* configurations, in which the embedded subject and the embedded direct object both raise to the matrix clause. For both of the intended meanings in (16),

the embedded subject must appear in dative form, when it appears in a cluster with the accusative-marked object clitic:

- (17) a. Se la hice lavar.
 him._{DAT} it._{ACC-FEM} I made wash._{INF}
 “I made/had him wash it.”
- b. *Lo la hice lavar.
 him._{ACC-MASC} it._{ACC-FEM} I made wash._{INF}
 “I made/had him wash it.”

A final group of verbs that can alternatively select objects marked with accusative and dative case belong to a class that in Latin and/or Medieval Spanish were structured differently than they are in Modern Spanish. In each case, the accusative clitic is more or less coming to replace the dative form, but the transition is still in process for many speakers, hence the continued alternation. This alternation affects verbs such as *ayudar* ‘help’, *aconsejar* ‘advise’, *avisar* ‘warn’, *enseñar* ‘teach’, *obedecer* ‘obey’, *picar* ‘bite’, *reñir* ‘tell off’, *regañar* ‘scold’, *temer* ‘fear’, and *amenazar* ‘threaten’ (Fernández-Ordóñez 1999: 14). In broad dialectal terms, the regions of Spain where real *leísmo* is spoken tend to maintain the dative usage for the objects of these verbs, while an active *le/lo* alternation for these verbs is most common in the Canary Islands and Andalucía. Full transition to accusative forms is most common in Latin America, especially in the Southern Cone countries of Perú, Argentina, Chile, and Uruguay (Fernández-Ordóñez 1999: 14). Take for instance the specific distribution of objects with the high frequency verb *ayudar* ‘help’. Even in non-*leísta* countries, speakers can alternate between *lo/la* and *le* when choosing the direct object complement of dynamic *ayudar*:

- (18) a. María está muy atareada, pero Juan le está ayudando.

María is very busy, but Juan her._{DAT} is helping

“María is very busy, but Juan is helping her.”

b. María está muy atareada, pero Juan la está ayudando.

María is very busy, but Juan her._{ACC-FEM} is helping

“María is very busy, but Juan is helping her.”

(Fernández-Ordóñez 1999: 14)

In *leísta* parts of Spain (e.g. Navarra, Aragón, La Mancha, Murcia, eastern Andalucía, Asturias, León, Extremadura) the verb *ayudar* selects the dative pronoun to denote the person receiving help (speakers almost always go with 18a). The selection of a dative-marked object for *ayudar* is also maintained, but to a lesser extent, in parts of the Canary Islands, Mexico and Central America. In these regions, there is greater alternation, thus both (18a and b) can be found to a varying degree. However, in western Andalucía, as well as South America, the accusative-clitic is almost always used with this verb (exclusively 18b). The distributions of the other verbs mentioned alongside *ayudar* show similar but not identical dialectal ranges, but the main point is that real *leísmo* is even found in Modern Spanish spoken in Latin America, albeit with a very small and restricted class of verbs. The evolution of these forms in Latin America, however, is clearly headed toward generalized case distinction (i.e. DO= ACC, IO= DAT).

Another form of apparent *leísmo* that differs from Peninsular *leísmo* is the possibility of referring to individuals normally addressed as *usted* with *le*. This is known as *leísmo de cortesía*, and is used to disambiguate reference to a third person direct object (*lo(s)*) from formal reference to an interlocutor (*le(s)*).

(19) a. Ayer lo vi en el parque (a él)

yesterday him._{ACC-MASC} I saw in the park to him

“Yesterday I saw him in the park.”

b. Ayer le vi en el parque (a usted)

yesterday him._{DAT} I saw in the park to you

“Yesterday I saw you in the park.”

c. Pedro ha venido ya. ¿Lo acompaño a la reunión?

Pedro has come already. him._{ACC-MASC} I accompany to the meeting

“Pedro is already here. Should I accompany him to the meeting?”

d. Pedro ha venido ya. ¿Le acompaño a la reunión?

Pedro has come already. you._{DAT-3P} I accompany to the meeting

“Pedro is already here. Should I accompany you to the meeting?”

(Fernández-Ordóñez 1999: 24)

Fernández-Ordóñez points out that this pragmatic form of *leísmo* is used much more commonly with masculine *usted* interlocutors than feminine *usted*—where *la* could be used instead, when formally addressing female interlocutors.

Finally, there is a third type of apparent *leísmo*, which entails the use of *le* as a direct object among highly educated speakers and writers (*leísmo culto*). This usage, also referred to as *leísmo como uso prestigioso* (‘*leísmo* as prestigious usage’), exclusively targets singular, masculine, animate direct object referents (as in Standard *leísmo*, centered in Madrid). Some of the preferred verbs used with dative DO’s in *leísmo culto* are *conocer* ‘meet’, ‘know’, *querer* ‘want’, *esperar* ‘expect’, ‘hope’, *llevar* ‘take’, and *ver* ‘see’. Like the *leísmo de cortesía*, *leísmo culto* is more of a pragmatic discourse marker than a full-fledged dialectal trait, since it is largely restricted to formal written and spoken registers.

3.4 *Laísmo, Loísmo*

In addition to *leísmo*, there is another well-known, but much less common, dialectal variation in the use of indirect object clitics, found mostly in Northwestern Spain. Recall that in most Spanish dialects, IO clitics only specify the phi-features of number and person, but not gender. There are, however, dialects in northwestern Spain where a gender distinction shows up regularly, and a distinction is made between masculine 3rd person IO *le(s)* and feminine *la(s)*.

- (20) a. Le envié el regalo (a él).

him._{DAT} I sent the gift to him

“I sent the gift to him.”

- b. La envié el regalo (a ella).

her._{ACC-FEM} I sent the gift to her

“I sent the gift to her”

(Romero 2013: 283)

Dialects that only mark feminine IO’s accusatively are called *laísta*, and belong to a phenomenon known as *laísmo*. Although *laísmo* is applied most regularly in the relevant dialects to singular animate feminine IO’s in double object constructions (cf. Romero 2013), there are also known instances where inanimate and plural IO’s get marked with feminine gender, as well as object experiencers that are marked datively in standard dialects (21):

- (21) a. Coges la sartén, la das la vuelta y ya tienes lista la tortilla.

you take the frying pan, you it._{ACC-FEM} give the turn and already you have ready the tortilla

“You take the frying pan, you give it a little flip, and your tortilla is ready.”

- b. A esas rosas hay que cortarlas los tallos secos.

to these roses must that cut._{INF} them._{ACC-PLUR-FEM} the stems dry

“You have cut the dry stems on these roses.”

c. A las niñas de hoy ya no las gusta coser.

to the girls of today already no them ACC-PLUR-FEM like sew-INF

“Today’s girls don’t like to sew.”

(Fernández-Ordóñez 1999: 2)

Romero (2013) argues that in most *laísta* dialects, the dative *la* is blocked in situations where accusative Case assignment is likewise blocked. He claims this is true with feminine IO’s in passives and unaccusative predicates. Observe the contrasts attested to in most *laísta* dialects:

(22) a. El regalo le fue enviado.

the gift her.DAT was sent

“The gift was sent to her.”

b. *El regalo la fue enviado.

the gift her. ACC-FEM was sent

“The gift was sent to her”

(23) a. La carta le llegó tarde.

the letter her.DAT arrived late

“The letter arrived to her late.”

b. *La carta la llegó tarde.

the letter her. ACC-FEM arrived late

“The letter arrived to her late.”

(Romero 2013: 285)

For these reasons, ‘standard’ *laísmo* is reminiscent of the double object construction in English, where the indirect object appears marked with morphological accusative case (e.g., I sent *him* the

phone). Romero argues that the above sentences suggest that the indirect object clitic is a pronoun, merged in a position able to receive structural accusative Case from the verb (Romero 2013: 292). We will not go into the specifics of his analysis, but simply note that the evidence he provides from *laísmo* is consistent with our idea that the IO clitic is a pronominal element merged in argument position in the v-Phase, where objective Case can be valued and deleted by features on object agreement heads v/V.

In addition to *laísmo*, there are dialects, also in Northwestern Spain, where *lo(s)* is used to refer to masculine and neuter IO's. The most common uses of *loísmo* are in reference to plural animate masculine IO's, but examples have also been found where singular animate as well as inanimate IO's referring to things and abstract concepts also get marked with *lo(s)*:

- (24) a. Cuando recojo a los niños del colegio, los llevo la merienda.
when I pick up to the kids from the school, them._{ACC-PLUR.MASC} I take the snack
“When I pick up the kids from school, I bring them their snack.”
- b. Cuando el arroz está cocido, lo echas la sal.
when the rice is cooked, it._{ACC-MASC} you put the salt
“When the rice is cooked, you put the salt on it.”
- c. Yo no lo doy ninguna importancia a eso.
I no it._{ACC-MASC} give none importance to that
“I don't give that any importance.”
- d. Cuando vi que el ladrón me iba a asaltar, lo pegué un empujón y salí corriendo.
when I saw that the thief me was going to assault, him._{ACC-MASC} I hit a push and I left
running
“When I saw that the thief was going to attack me, I hit him and left running.”

(Fernández-Ordóñez 2: 1999)

Fernández-Ordóñez makes an interesting related point, and that is that many traditional grammarians from Spain have referred to speakers who regularly distinguish objective cases (i.e. DO= ACC, IO= DAT) as *loístas*. This tendency on the part of ‘old school’ grammarians has created confusion between case distinction (*distinción*) and real *loísmo* (*confusión entre dativo y acusativo*). Therefore, she recommends the use of the terms *distinguidor* (‘distinguishing’) and *confundidor* (‘confusing’) when talking about dialects that regularly distinguish direct and indirect objects by case and those that do not (1999: 3). We will adopt her terminology, and accordingly refer to the *-ísmos* of Spain as *dialectos confundidores de caso*.

3.5 *Porteño*

Having reviewed the most traditionally studied types of dialectal variation with clitics in the Iberian Peninsula, now consider an interesting Latin American dialect with regard to clitics, that of the Río de la Plata region (a.k.a., *rioplatense*, *Porteño*). In this mostly urban dialect spoken in Buenos Aires and a large area of Argentina and Uruguay, the accusative-marked DO clitic can be doubled by a specific, animate DP. Recall that in Standard Spanish, the DO clitic can only be doubled by a strong pronoun and a universal quantifier. We represent the major distinction between the world Standard (a) and *Porteño* (b) thusly:

- (25) a. Lo vi (a él/ *a Juan/ *al hombre)
him. ACC-MASC I saw to him to Juan to the man
“I saw him/ Juan/ the man”
- b. Lo vi (a él/ a Juan/ al hombre)
him. ACC-MASC I saw to him to Juan to the man

“I saw him/ Juan/ the man”

However, there are very restricted conditions under which the DO can be doubled in this dialect. If the DO is non-specific (as in (26a)), or inanimate (as in (27a)), then doubling in this dialect is generally ruled out. Notice that even with indefinite DP's that get modified to denote a specific referent (as in the DP in (28)), doubling is allowed.

(26) a. (*La) invitó a una cantante.

her._{ACC·FEM} invited to a singer

“S/he invited a singer”

b. (La) invitó a la cantante.

her._{ACC·FEM} invited to the singer

“S/he invited the singer”

(27) a. (*La) dibujó la manzana ayer.

it._{ACC·FEM} drew the apple yesterday

“S/he drew the apple yesterday”

b. (La) dibujó a María/ a la niña/ a la gata ayer.

it pro drew to María/to the girl/to the cat yesterday

“S/he drew María/ the girl/ the cat yesterday.”

(28) Diariamente, (la) escuchaba a una mujer que cantaba tangos.

Daily her._{ACC·FEM} listened to a woman that sang tangos

“On a daily basis, s/he listened to a woman who sang tangos.”

(Suñer 1988: 396)

In some instances, however, native speakers of this dialect have been recorded doubling inanimate DO's. Suñer notes, however, that in many of these cases, Kayne's generalization still

holds, as the DP double must be introduced via the Case-marking morpheme *a*. This is observed in her recorded examples in (29):

- (29) a...lo vamos a empujar al ómnibus.
...it._{ACC·MASC} we will to push to the bus
“...we are going to push the bus.”
- b. Lo quiero mucho a este arbolito porque me lo regaló mamá.
it._{ACC·MASC} I love a lot to this tree little because me it gave mother
“I love this tree a lot because my mother gave it to me.”
(Suñer 1988: 399)

However, there exist sentences uttered by speakers of this dialect that do not appear to support Kayne’s generalization. In these sentences the double is not introduced via the case-marker *a*:

- (30) a. Yo la tenía prevista esta muerte.
I it._{ACC·FEM} had foreseen this death
“I had foreseen this death.”
- b. ¿Así que el tarambana de Octavio la liquidó su fortuna?
this way that the scatterbrain of Octavio it._{ACC·FEM} squandered his fortune
“Isn’t it true the empty-headed Octavio squandered his fortune.”
- c. Lo último que escuché, claro que la encontré pesada la audición, fue el reportaje.
the last, the I heard, of course that it._{ACC·FEM}I found boring the radio program, was the interview
“The last thing that I listened to, of course I found it boring, the (radio)-program, was the interview.”

d. Ahora tiene que seguir usándolo el apellido.

Now s/he has to continue using it._{ACC·MASC} the surname

“Now s/he has to go on using the surname.”

(Suñer 1988: 399)

e. Yo lo voy a comprar el diario justo antes de subir.

I it._{ACC·MASC} I am to buy the newspaper just before of come up

“I am going to buy the newspaper just before coming up.”

(Suñer 1988: 399-400)

These sentences are very well known by now, since they are usually cited as evidence that Kayne’s generalization does not hold universally. Recall that his generalization predicts that in all clitic-doubling languages, the full DP double cannot receive Case directly because the clitic absorbs Case assignment from the verb. However, in the above examples cited by Suñer, the double is not introduced via the case-marker *a*, and this suggests that the doubled DP is in fact licensed by the verb. Suñer concludes that in these sentences the clitic cannot be in argument position, and, therefore, is an agreement morpheme, generated in a functional category (see Fig. 2.3, Sec. 2.2). As our own analysis hinges on clitic facts from standard dialects of Spanish, we do not mind to concede this point, as it is possible that in *Porteño* the clitic has undergone a change from its original pronominal function. However, it is worth noting that the DO clitic is OPTIONAL in all of the doubling cases cited as *Porteño* dialectal variation. For the clitic to be considered true agreement morphology, however, we might expect it to be mandatory in all relevant constructions. For instance, in subject verb agreement in Spanish, agreement marking on the end of verbs is not optional. In fact, with regard to all other types of overt agreement in Spanish, extending also to number and gender agreement on adjectives, agreement is mandatory.

In Figure 3.2 above, the verb assigns Case to the entire big DP—including the clitic and its double (cf. Uriagereka 1995 for the ‘big DP hypothesis’). The verb carries a feature that attracts the clitic (see the ‘affix’ feature discussed in Chapter 5), which forces head-to-head incorporation of the clitic into V, which deletes the affix feature from the verb, where it is uninterpretable to Logical Form. The clitic then moves to v^* and finally T via roll up of the complex verb head.

A final caveat related to doubling facts of *Porteño* Spanish emerges in constructions with two object clitics. As was the case with *leísmo*, we can get a better sense of what is going on with morphological variation when we add structures. Interestingly, when we add a dative clitic in Rioplatense Spanish, the agreement effect with the DO is lost. That is, the presence of the dative argument appears to block Suñer’s proposed agreement mechanism, and the DO no longer can double. Observe the following contrasts in *Porteño* (also applicable to standard dialects):

- (31) a. *Juan se la presentó la enfermera al doctor.

Juan him._{DAT} her._{ACC-FEM} introduced the nurse to the doctor

“Juan introduced the nurse to the doctor.”

- b. *Juan se la presentó María al doctor.

Juan him._{DAT} her._{ACC-FEM} presented María to the doctor

“Juan introduced María to the doctor.”

- (32) a. Juan le presentó la enfermera al doctor.

Juan him._{DAT} presented the nurse to the doctor

“Juan introduced the nurse to the doctor.”

- b. Juan se la presentó al doctor.

Juan him._{DAT} her._{ACC-FEM} presented to the doctor

“Juan introduced her to the doctor.”

(Zdrojewski 2008: 41).

When the dative argument is also present in the form of the dative clitic, the DO appears to act as a pronoun again. Zdrojewski (2008) interprets this to mean that in *Porteño* there are two types of DO clitics—an agreement morpheme and a pronoun. His argument is one of complementary distribution—in this dialect, the pronoun shows up in different contexts than the agreement marker. If his analysis is on the right track, then we can say that even in *Porteño* Spanish, the direct object clitic still behaves as a pronominal, as the movement analysis is needed to derive IO-DO clitic clusters in this dialect. This lends further support to our proposal that all object clitics in *Porteño* are pronouns, and as such, exhibit movement, as shown in Fig. 3.2 above. We can thus also dispense with the necessity of Kayne’s Generalization to explain clitic doubling, as clitic movement can proceed without it, given the assumptions we outlined above. To recap, the verb assigns abstract accusative Case to both the clitic and double in the big DP, but the clitic nevertheless moves to attach to the verb because of the presence of an uninterpretable ‘affix’ feature on the clitic that must be deleted before the structure is sent to Logical Form (LF).

3.6 *Andino*, Los Angeles Vernacular Spanish (LAVS)

Although most of the Base Generation accounts in the literature cite the *rioplatense* examples of DO doubling to make their case against a movement account of Romance clitics, a careful analysis of the facts showed that there is a clitic determiner in that dialect that obeys Kayne’s Generalization. It would perhaps be more fitting then to cite other dialects of Spanish as the standard-bearers of Base Generation. Specifically, there are dialects in contact with other languages, in which clitics have been shown repeatedly not to obey Kayne’s Generalization. First,

observe some recorded examples of DO clitic use in so-called Andean Spanish (*español andino*), which is in heavy contact with indigenous languages of the areas, predominantly Quechua:

- (33) a. Me la han roto mi cometa.
me.DAT it.ACC.FEM they have broken my comet
“They have broken my kite.”
- b. No lo vi a sus hermanitos.
No it.ACC.SING.MASC I saw to his/her brothers.PLUR
“I didn’t see his brothers.”
- c. Se lo llevó una caja.
him.DAT it.ACC.MASC stole a box.FEM
“S/he stole the box on him/her.”

(Luján and Parodi 2001: 193)

In (33a), the DO clitic can be doubled by a full pronoun in a cluster that includes the dative *me*, which was the very configuration that disallowed doubling in *rioplatense* Spanish. In (33b), the DO clitic once again can be doubled, even when number agreement fails to obtain between the double and the clitic. In (33c), there is a gender mismatch between clitic and double, but once again, the DO can be readily doubled. This dialect raises an important question: if there is no overt agreement in phi-features between the clitic and its double, can we still call the clitic an agreement morpheme? It is only an agreement marker in the sense that it is an element generated with the verb to signal ‘abstract’ Agreement with the direct object, in Chomsky’s technical sense of Agree in Phase Theory. We assume in this case that the morphology yields the default 3rd person masculine singular pronoun (i.e., *lo*) to signal abstract agreement between the verb and its DO, as seems to be the case in (33b and c). As the distinction between overt and abstract

agreement is potentially confusing, we will refer to non-agreeing clitics as object markers, since overtly they only indicate the presence of post-verbal object. We will reserve the term agreement morpheme for functional clitics in dialects where they do agree in phi-features with the double, such as the spontaneously recorded examples from *Porteño* Spanish observed by Suñer.

Similar patterns with clitics obtain in Los Angeles Vernacular Spanish (LAVS), a dialect with rural Mexican Spanish roots that now predominates among the colloquial variants of Spanish spoken throughout the Los Angeles Metropolitan area. Most of the native speakers of this dialect are also fluent in English, which accounts for a great deal of transfer of lexical items and grammatical koineization. Nevertheless, this is a dialect of Spanish, not English, and is spoken by the majority of the Hispanic working class in the five counties that comprise the L.A. area (i.e., Los Angeles, Orange, San Bernadino, Ventura, Riverside). This dialect is also referred to by Parodi (2011) as *el vernáculo de Los Ángeles* or *español chicano* (4). Syntactically, this dialect is interesting because of its ‘redundant’ use of subject and object pronouns, which distinguishes it from monolingual variants of Spanish (Parodi 2009a: 6). In most monolingual variants of Spanish, subject pronouns are rarely used, as Spanish is a null subject language. Thus, in the Standard subject pronouns are typically reserved for pragmatic purposes, namely to clarify, emphasize, and focus/topicalize subject constituents. In LAVS, however, subject pronouns are used in non-emphatic contexts. Similarly, with regard to object pronouns, it is common in LAVS to double DO clitics. Consider the following examples of pronoun use, taken from a Los Angeles radio program conducted in Spanish, *La radio que habla* (KTNQ-AM 1020):

- (34) a. Este es un consejo para nosotras, las mujeres, porque nosotras somos muy impulsivas.

“This is advice for us, women, because we are very impulsive.”

b. Usted me lo dejó el mensaje con Juan.

you.formal me.DAT lo.ACC.MASC left the message with Juan

“You left the message for me with Juan.”

(Parodi 2009a: 6)

The underlined pronouns represent the redundant usages of subject and object pronouns that grammatically distinguish LAVS from the Standard. Note that the DO clitic in (34b) is a true agreement morpheme, since it projects a double that is not introduced with an *a*-phrase.

Although clitic doubling is a general characteristic of LAVS, agreement is more pronounced in formal and professional registers of the dialect, such as those employed by the radio announcer in the examples above. As Parodi points out, agreement alternates with non-agreement in more colloquial contexts. The alternation is so pronounced that lack of agreement is taken to be the norm outside of formal contexts. Observe further instances of doubling in Los Angeles Spanish:

(35) a. Lo veo la niña.

it.ACC.MASC I see the girl.*FEM*

“I see the girl.”

b. La dejó el coche en la esquina.

it.ACC.FEM pro left the car.*MASC* in the corner

“S/he left the car on the corner.”

c. ¿Me lo das el dinero?

me.DAT it.ACC.MASC you give the money

“Will you give me the money?”

(Parodi 2009a: 6)

In addition to the examples with gender mismatch between the clitic and double, this dialect is particularly interesting because of sentences like (35a), where Kayne's Generalization does not even hold when the object is +animate and +specific. The doubling in LAVS thus appears to be the most unrestricted, as the doubled clitics observed in the Andean Spanish data still required the Case morpheme *a* for animate referents. To explain the placement of these elements, Luján and Parodi (2001) argue that morpheme clitics be generated in AGR projections, as functional heads. We accept their analysis, although in more recent frameworks, it is standard to dispense with AGR (S and O), and instead adopt T and v as the loci of subject and object agreement, respectively. Hence, in a Base Generation account of clitics in LAVS, we would generate the DO clitic in v, adjoined to the verb, and move it to T as part of v-T movement (see Fig. 2.4, Sec. 2.2). Interestingly, it appears that all of the 'doubling' dialects still conform to the Standard in their use of IO clitics. As far as we know, the IO clitics in these dialects obey Kayne's Generalization, and must be doubled with an *a*-phrase. Hence in these dialects, it appears that the dative clitic has not yet lost its pronominal function, despite the deviation noted in the case of DO clitics.

3.7 ¡Órale!: Expletive Clitics

A final interesting dialectal feature of LAVS, Mexican Spanish, and colloquial Latin American varieties more generally, is the use of expletive clitics. These clitics, like the inherent reflexive and speaker dative clitics observed in Chapter 1, cannot be related syntactically to a post-verbal argument. Expletive clitics are usually enclitic, and are found in popular Latin American expressions such as the following:

- (36) a. ¡Córrale!

run CL.DAT

“Run!”

b. *Ándale.*

go CL.DAT

“Go ahead.”

c. *¿Quihúbole?*

What there was CL.DAT

“What’s up?”

d. *¡Híjole!*

son CL.DAT

“Wow!”

e. *¡Órale!*

now CL.DAT

“Right!” “Come on!”

f. *¡Guácala!*

money CL.ACC.FEM

“Gross!”

(Parodi 2009a: 7).

These clitics do not refer to actual objects, but in most of these constructions they seem to have some exclamatory or emphatic function. Syntactically, they could be generated as the spell-out of force features in C, as they appear to denote exclamative force in the affirmative examples. One could speculate that they become enclitic when the element they attach to moves to the periphery, attracted by strong force features on C. However, there are other expletive clitics

selected by verbs that need not denote exclamation, such as *arreglárselas* ‘cope’, ‘manage’, *habérselas* ‘fight’, ‘struggle with’, *vérselas con alguien* ‘contend with someone’, ‘componérselas’ ‘find a way out of trouble’, *pegársela* ‘bump into’, ‘deceive’, *pasarlo bien* ‘have fun’, etc. (cf. Fernández Soriano 1993: 30). Although a detailed formal analysis of expletive clitic constructions in colloquial Latin American Spanish is beyond the scope of the present work, such an investigation would make an excellent topic for future research.

3.8 Clitic Duplicating Varieties *en Sudamérica*

Returning to clitics that can be related to syntax, it is important to stress that although the doubling varieties of Porteño and Andino Spanish are often cited as dialectal evidence against movement there are other dialects from South American Spanish that actually suggest movement. The most transparent dialect of Spanish in terms of movement is that of clitic duplication in various South American countries, including Bolivia, Perú, Argentina, and Chile. In these dialects, the clitic is spelled out in its base and derived position, as in (37)⁴:

(37) a. Yo lo iba a hacerlo.

I it._{ACC-MASC} was going to do it._{ACC-MASC}

‘I was going to do it.’

(Argentina; Nunes 2004: 45).

b. No la he podido conocerla.

no her._{ACC-FEM} I have been able to meet her._{ACC-FEM}

‘I haven’t been able to meet her.’

(Bolivia; Lipski 1994: 191).

c. Me está castigándome.

⁴ For reasons why the trace of clitic movement is phonetically realized, see Nunes (2004).

me she is punishing me

“She is punishing me.”

(Perú; Lipski 1994: 191).

In accordance with the analysis to be put forth in Chapter 5, in which dative and accusative clitics move together, clitic duplication phenomena are not limited to accusative clitics. Speakers of Chilean Spanish can also duplicate dative clitics, as well as the entire IO-DO clitic sequence (attested to in spoken Chilean Spanish by Silva-Corvalán 1979, Mann 2012).

(38) a. Le iban a ofrecerle ayuda a la niña

her.DAT they were going offer.INF her.DAT help to the girl.

“They were going to offer help to the girl.”

(Mann 2012: 28)

b. Ya se lo puedo decírselo

now him.DAT it.ACC-MASC I can tell.INF him.DAT it.ACC-MASC

“Now I can tell it to him.”

(Mann 2012: 28)

c. Yo se la estaba pasándosela.

I him.DAT her.ACC-FEM was giving him.DAT her.ACC-FEM

“I was giving her to him.”

(Silva-Corvalán 1979: 64)

d. Y la Sra. M. decía que iba a ir a buscar los detectives po, y que me los iba echármelos.

“And Ms. M. said that she was going to go get the detectives, and that she would confront me with them.”

(Silva-Corvalán 1979: 73)

All of the above examples of clitic duplication involve movement of the clitic in presumably monoclausal configurations, with the higher copy attaching to the front of the auxiliary verb. Nunes has found an Argentinian dialect where the higher copy shows signs of having moved into a different clause from its base position. Observe the contrast in (39), where the clitic can move above the lexical verb *intentar* ‘try’ but not the (also lexical) *odiar* ‘hate’:

(39) a. Lo iba a intentar hacerlo.

it.ACC·MASC was going try·INF do·INF it.ACC·MASC

‘I was going to try to do it.’

b. (*Lo) iba a odiar hacerlo.

it.ACC·MASC was going hate·INF do·INF it.ACC·MASC

‘I would hate to do it.’

(Nunes 2004: 46)

The difference here is that in (a) the intermediate verb form *intentar* is a clitic-climbing verb in Spanish, while *odiar* is not. Duplication is allowed as long as there are no barriers to movement—in Nunes’s analysis, as well as our own, *odiar* blocks the clitic from attaching to its auxiliary *ir* ‘go’. In line with other observed intervention effects in language, this pattern evokes movement. As for the duplication operation itself, this is not wholly unattested in other languages. In fact, it is reminiscent of phenomena in languages such as Afrikaans, German, Romani, Frisian, and Child English, which readily allow cases of long-distance questions in which the *wh*-phrase appears to be repeated in an intermediate position. Consider the following examples from Romani (a), Frisian (b) and Child English (c):

(40) a. **Kas** misline **kas** o Demiri dikhla

whom you-think who the Demir saw

“Who do you think the Demir saw?”

b. Wer tinke jo wer’t Jan wennet?

where think you where-that Jan lives

“Where do you think that Jan lives?”

c. Who do you think who the cat chased?

(Boeckx 2008: 28).

There are even recorded instances of phonetically realized copies of verb movement, which is structurally more akin to clitic movement, being head movement. Koopman (1984) has argued that a focused verb in Vata moves to C^0 leaving behind a copy, as in (41):

(41) a. **li** à **li**-da zué saká

eat we eat-PAST yesterday rice

“We ATE rice yesterday”

b. **li** O da saka **li**

eat s/he PERF.AUX rice eat

“S/he has EATEN rice.”

As the above cases are standardly construed as evidence of movement via copying, we suggest that clitic duplication phenomena in Southern Cone Spanish be interpreted in a similar fashion.

3.9 Concluding Remarks

We began this exploration of dialectal variation with clitics with an open mind, ready to accept the fact that the object clitics of Spanish may be evolving into agreement or object markers in many of the attested dialects. We could have been forced to conclude that clitics, far

from representing a unified class for speakers of Spanish worldwide, are fragmented into various types of elements, depending on the dialect. We might have been forced to admit that our movement analysis was based on a merely prescriptive standard upheld by royal grammarians in Madrid but not attested to by actual speakers in different countries. Furthermore, we feared we might have to bid *adieu* to Kayne's Generalization and accept the fact that Spanish as a whole does not conform to his rule. The reality of the situation, however, turned out to be much more sanguine for our theoretical outlook than expected. In most studied dialects, argument clitics⁵ behave like pronouns, despite superficial morphological variation, as exemplified in *leísmo*, *laísmo* and *loísmo*. In *leísta* dialects, we saw that the presence of an intervening IO clitic between the DO and verb blocks dative Case assignment to the DO. This was expected under our assumptions about the underlying syntax of these configurations—the IO clitic occupies [Spec, VP] and, consequently, is the closest goal to dative-Case assigning head, v^* . With the IO clitic in the way, v^* cannot see the DO to mark it accusatively.

A movement theory of clitics was also suggested by the Mexican phenomenon of 'parasitic plurals.' The transmission of plurality from the IO to DO clitic in this dialect must occur in a very local environment, which we foreshadowed with our head to head adjunction of these elements. This transmission takes place once the dative clitic merges into the 'minimal specifier' of the accusative clitic, via the operation of head movement, which we will have more to say about shortly, in our Chapter 3 review of Roberts (2010a).

⁵ Once again we distinguish argument clitics that can be related to syntactic arguments from the Case-less clitics that we observed in the first two chapters. We assume that inherent reflexives, speaker datives, as well as expletive clitics, although homophonous with argument clitic pronouns, nevertheless differ crucially from Case clitics with regard to their role in the syntactic derivation. Although many traditional grammarians have cited these clitics as a challenge to movement analyses, we contend that this comparison is a category error, as they behave differently from determiner clitics in every regard except their phonology.

We thought we might be in trouble when we moved from morphological variants to doubling varieties, but the doubling variety *par excellence*, of the Río de la Plata, entails a complex and subtle array of facts, most of which actually obey Kayne's Generalization. We concede a Base Generation account for speakers who don't obey that generalization, and can thus double clitics without an accompanying *a*-phrase. As we saw though, Base Generation is most ideally suited for dialects like *andino* Spanish and Los Angeles Vernacular Spanish, where DO clitics can be doubled without an *a*-phrase, even in the presence of a dative clitic. *Porteño* Spanish, however, appears to be a mixed dialect, with some DO clitics behaving as agreement elements, while others are clearly still pronouns.

Finally, we saw that not all Argentinean dialects are problematic for movement, as various dialects spoken in other parts of Argentina besides the Río de la Plata involve the pronunciation of the clitic in both argument and derived position. These dialects, also attested to in parts of Chile, Perú, and Bolivia, exhibit clitic duplication. Unlike an agreement element that presumably knows no barriers, clitics in many of these dialects can only be duplicated in standard clitic-climbing environments. Islands like these are expected under movement accounts. Thus, far from us convincing us stick to the Standard data, we are encouraged by the studies of dialectal variation that movement, although sometimes obscured by variation in morphology, can still be detected in many dialects with the help of added structures and the standard diagnostics to test for displacement. Having addressed dialectal concerns, we now move on to state-of-the-art accounts of movement. We will closely examine the details of Phase Theory, as well as Roberts's groundbreaking work to recast head movement in the framework of Bare Phrase Structure (Chomsky 1995a). We will consider his cutting edge account of clitics, and explain where we follow him and where we diverge from his analysis.

CHAPTER 4

Phase Theory, Minimality, and Head Movement

4.1 Clitics in Phase Theory

With the basic clitic facts from Standard and dialectal varieties of Spanish in tow, we can begin to account for these facts from a principled, theoretical perspective. First, we must enumerate the crucial theoretical assumptions that will inform our analysis. Accordingly, we will begin this chapter with a review of crucial developments within Phase Theory, the most recent conception of the computational system of human language (CHL). We will carefully review the key developments within this theory that directly bear on our own approach, namely movement of object clitics. We will begin with a brief review of Chomsky's foundational works within the framework of phases, and then look at the conditions on movement known as Minimality. Specifically, we will examine Rizzi's latest feature-based account of Relativized Minimality (2013), which will serve as the principle we use to explain intervention effects in this work. Once we clearly outline the foundational assumptions of Phase Theory, we will move onto the work that has most inspired our own technical implementation of clitics by phase: Roberts (2010a).

We will incorporate several parts of his latest head movement analysis. We distinguish Roberts's account from earlier landmark accounts of clitic movement, such as Quicoli (1976), as the former is recast in terms of Bare Phrase Structure and Phase Theory.¹

Returning to Roberts, we must stress that we will not adopt all of his assumptions regarding clitics. As we mentioned from the outset, we will crucially deviate from his conception of clitics as Caseless ϕ -elements. Stripping clitics of their determiner status deprives them of their status as full-fledged arguments, and fails to account for the great number of similarities between determiners and clitics we have already noted in Chapter 2.

4.2 Phase Theory: A Brief Review

For our analysis, we adopt aspects of the framework of Chomsky (2000, 2001, 2004, 2008, 2013). In Phase Theory, there is only one level of syntactic representation, the phase. This study therefore assumes the following representation of language processing in Figure 4.1 (Quicoli 2008: 303):

Figure 4.1: Model of Grammar in Phase Theory

¹ However, we would be remiss not to acknowledge here the influence of Quicoli's study on our work, since it was his analysis of clitic movement in Portuguese that first inspired our own interest in the topic of clitics from a theoretical perspective.

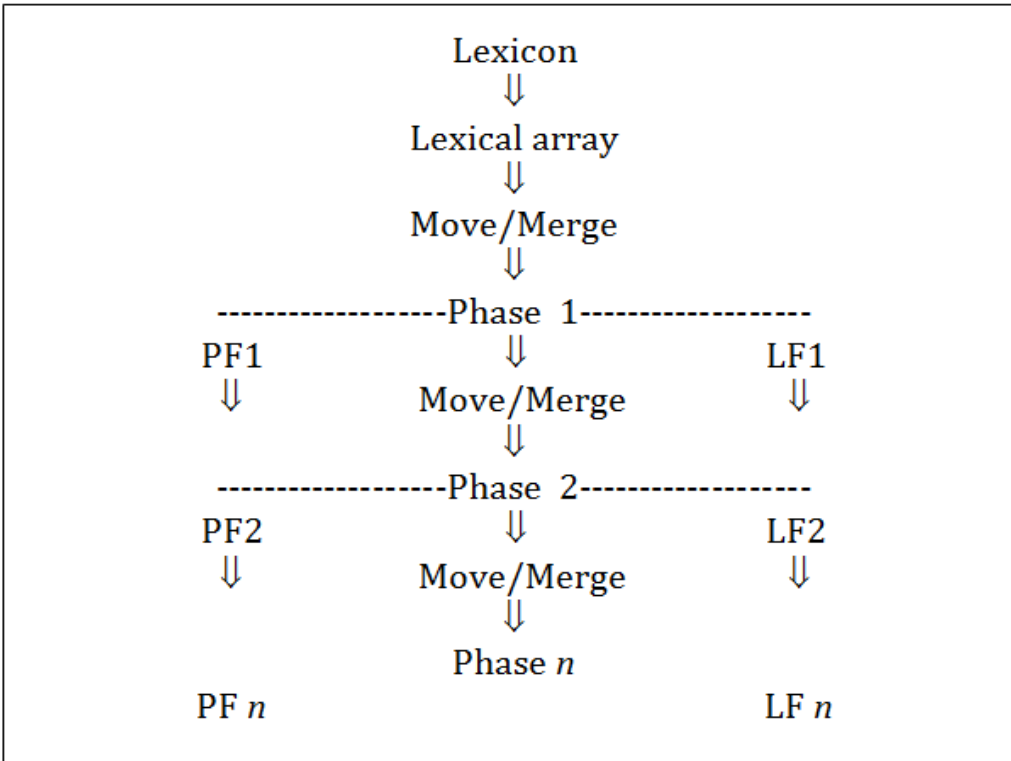

In Figure 4.1, the lexicon is a list of all of the units or lexical items (LIs) that we can put in our derivation of a sentence. It therefore not only includes ‘vocabulary’ words such as the Spanish *comprar* ‘buy,’ *auto* ‘car,’ and *en* ‘in,’ but also proper nouns such as *María* and grammatical features such person, number, and gender, as well as tense, verb, EPP, and abstract Case features. To form a derivation, lexical items are selected from the lexicon to arrive at a ‘lexical array’, which is the specific set of items that will be used to generate a given sentence. These items are then plugged into the syntactic derivation via the operation of External Merge, and enter into further operations, such as Agree and Move (a.k.a., Internal Merge).

As we can see in Fig. 4.1 above, the derivation proceeds in a piecemeal fashion, phase by phase. Chomsky takes phase domains to encompass phase heads (v^* and C) and their specifiers.² The phase heads, as well as the heads they immediately select (V and T), are the initiators of

² v^* is the functional head associated with full argument structure, transitive and experiencer constructions (Chomsky 2008: 143).

syntactic operations and thus serve as ‘probes’ that enter into Agree relations with expressions below them, known as ‘goals’.

In order to be visible at a higher phase and thus active for further syntactic operations, goals must move to the left edge of a phase domain. Goals that fail to move to a phase edge are ‘impenetrable’, that is, inaccessible to higher probes, according to the Phase Impenetrability Condition (PIC). The PIC can be stated formally as follows, with H the head of a phase:

- (1) The domain of H is not accessible to operations outside HP; only H and its *edge* are accessible to such operations (Chomsky 2001: 13).

The reason why the domain of H is impenetrable to a higher probe is that once a complete phase has been formed, the complement of H undergoes a Transfer operation. During Transfer, the relevant structure is simultaneously sent to the phonological component (PF), to be assigned an appropriate phonetic representation, and the logical form component (LF), to be assigned an appropriate semantic interpretation. From that point on, the relevant domain is no longer accessible to the syntax. For example, once a CP phase has been formed, phase head C and the T head that it directly selects will only be able to find a suitable goal with which to agree in v^* and in the edge of v^* (i.e., in [Spec, v^* P]). This can be visualized in Figure 4.2:

Figure 4.2: Phase Search Space and Complement Domains

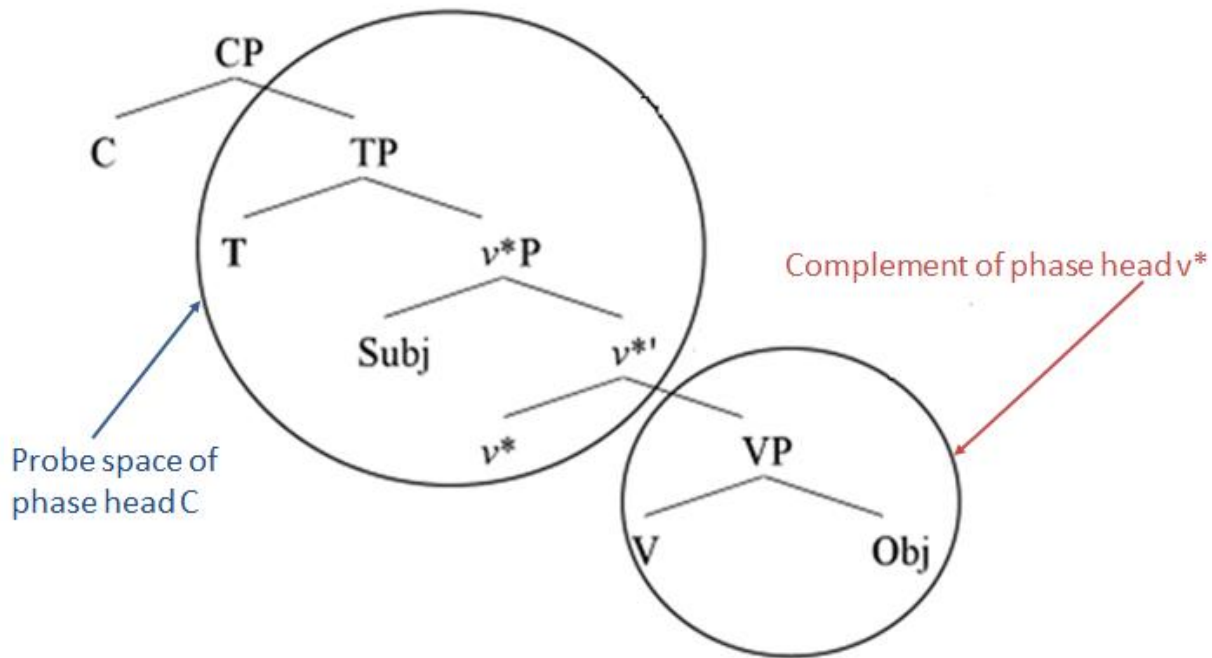

As we can see in Figure 4.2, once the C-phase is built up, the domain of v^* (i.e., VP) gets transferred to the interfaces and becomes inaccessible to operations in the C-phase. The phase head C, however, can access items in the phase head v^* , [Spec, v^*P], as well as T. Crucially, C not only sees all lexical items in its search space, but features as well.

4.3 Role of Features in Phase Theory

This brings us to another important aspect of Phase Theory, the concept of features. As we alluded to above, the structures manipulated by syntax are Lexical Items (LIs) composed of feature bundles, and these features may enter the derivation already valued or unvalued. By the end of each phase though, all relevant features must be valued and then sent to the appropriate interface or get deleted (more on this below). The effect of the operation Agree is to match already valued features with corresponding unvalued features and in the process value them.

Chomsky (2000) argues that the difference between valued and unvalued grammatical features correlates with a related distinction between those grammatical features that play a role in semantic interpretation, dubbed ‘interpretable,’ and those that do not play a role in semantic interpretation, hence ‘uninterpretable.’ The ϕ -features of nominal expressions (person/number/gender) are interpretable, since, for example, a first person singular pronoun like *yo* clearly differs in meaning from a third person plural feminine pronoun like *ellas*. All nominal expressions enter the syntax with their interpretable ϕ -features already valued. Nouns and pronouns also enter the derivation carrying an abstract Case feature, which is uninterpretable. The Case feature on a nominal is uninterpretable because, for instance, whether a subject pronoun surfaces as nominative, accusative, or genitive depends only on the type of clause it is in, not on its thematic or semantic role in that sentence. This is illustrated in the English examples below, where the third person pronoun appears in three different forms:

- (2)
- a. It seems [*they* were arrested]
 - b. He expected [*them* to be arrested]
 - c. He was shocked at [*their* being arrested]

To recap then, nominal expressions enter the derivation with their interpretable ϕ -features valued and their uninterpretable Case feature unvalued. Now let’s consider the feature content of probes that drive the derivation upward by probing down into the phase below them. In contrast with nominal goals, the ϕ -features of the probes *v* and *T* are not interpretable. This can be understood by recalling that the ϕ -features of tensed main verbs and auxiliaries only serve to mark agreement with a particular nominal, as we can see in the contrast below:

- (3)
- a. Ellos están trabajando.

they are working

“They are working.”

b. *Ellos está trabajando.

they is working

“They are working.’

c. Ellos fueron encarcelados.

they were incarcerated._{PPRT·PLUR}

d. *Ellos fueron encarcelado.

they were incarcerated._{PPRT·SING}

“They were incarcerated.”

As we can see here, if we replace the third person plural auxiliary *están* with the third singular form *está*, we do not change the meaning of the sentence, but simply render it ungrammatical. The same is true of agreement features on a participle. Thus the ϕ -features on v^* and T are uninterpretable, and hence initially unvalued upon entering the derivation.³ The T and v^* heads also contain uninterpretable EPP features, which serve as the triggers of Move to the specifiers of those heads (and to the heads themselves, in the case of head movement). It should be noted that phase heads may carry other features, called Edge features, including those related to grammatical force (e.g. *+wh*), as well as focus, and topicalization.

Chomsky (2008) further posits that C is the original locus of T’s ϕ -features, which percolate down to T via ‘feature Inheritance.’ Before we examine in more detail the interplay of

³ However, v^* and T do have interpretable features in some versions of this theory. T naturally carries an interpretable tense feature [\pm PAST] and v carries an interpretable V feature related to the possession of argument structure (cf. Biberauer and Roberts 2010). Also, Roberts (2010a) argues that to trigger v -to-T movement in languages like Spanish and French, there should be a matching uninterpretable T feature on v^* , and an uninterpretable V feature on T (161).

features and phase heads in the course of the syntactic derivation, let's first consider why features play such an essential role in Phase Theory.

4.4 Delete or Crash: Uninterpretable Features

As we saw in the model of grammar outlined above, each structure generated by the syntax is subsequently sent to the PF component to be 'spelled out,' i.e. assigned a PF representation which provides a representation of its Phonetic Form, and to LF, to receive a semantic interpretation. In Phase Theory, however, unvalued uninterpretable features cannot be read by the interfaces and thus cause the derivation to 'crash.'

That is, unvalued features are illegible to PF and uninterpretable features are illegible to LF. With regard to PF, unless the syntax specifies via feature valuation whether we require, for example, a first person singular or third person plural present tense form of the verb *ESTAR*, the derivation will crash because the PF component cannot determine whether to spell out *ESTAR* as *estoy* or *están*. This is the problem that unvalued features pose for PF. Now, consider LF. Interpretable features by definition play a role in semantic interpretation and thus feed into LF, while uninterpretable features play no role in that process and cannot help but cause an LF crash. The question, then, becomes how to prevent unvalued features from feeding into PF and how to prevent uninterpretable features from feeding into LF. Phase Theory answers this question by postulating that in the course of the derivation unvalued features get valued before they get sent to PF and uninterpretable features get deleted before they reach LF.

A lexical item is thus only active for an operation like Agree or Move if it carries an unvalued uninterpretable feature of some kind, and once the relevant uninterpretable feature has

been deleted, the lexical item carrying it becomes inactive for further operations of that kind. For instance, once a subject nominal carrying uninterpretable Case agrees with T and then moves to the spec of TP to delete its Case feature, it is rendered inactive for further operations, and is ‘frozen in place’ (Chomsky 2001: 6). This is commonly known as the Activity Condition.

However, if agreement with a probe inactivates a goal, then how can we account for a sentence such as (3c), *Ellos fueron encarcelados* (‘They were incarcerated’)? *Ellos* agrees with both the participle verb, *encarcelados*, and the auxiliary verb *fueron*. If Chomsky’s Activity Condition is on the right track, then it must be able to account for such cases of multiple agreement. Chomsky does so by suggesting that some forms of agreement, such as participial agreement, are ‘defective.’ That is, participial-object agreement is adjectival in nature, involving only the phi-features of number and gender, not person (Chomsky 2001: 18). This point can be made explicit by comparing subject-verb agreement morphology with participle agreement in Spanish. Unlike overt subject-verb agreement in null subject languages, where person agreement is overtly marked on the verb, there is no such person agreement marking on noun-agreeing adjectives and participles. This contrast can be seen below in (4) and (5) in the 1st, 2nd, and 3rd person singular conjugations on the ending of these verb forms:

(4) a. Yo hablo.

I speak

“I speak”

b. Tú hablas.

you speak

“You speak”

c. Él habla.

he speaks

“He speaks”

(5) a. Yo fui encarcelado.

I was incarcerated._{PPRT}

“I was incarcerated.”

b. Tú fuiste encarcelado.

you were incarcerated._{PPRT}

“You were incarcerated”

c. Él fue encarcelado.

he was incarcerated._{PPRT}

“He was incarcerated.”

The above sentences show that the person feature is present in subject-verb agreement but not in participle agreement. Since there is no person marking on participle agreement, we conclude that participles enter the derivation only carrying number and gender. Agreement with participles is dubbed defective since the noun cannot be assigned Case and rendered inactive by a probe that lacks the person phi-feature. This is explained in the Completeness Condition:

(6) “ α must have a complete set of ϕ -features (it must be ϕ -complete) to delete

uninterpretable features of the paired matching element β ” (Chomsky 2001: 6).

The Completeness Condition predicts that agreement between the participle *encarcelados* and the noun *Ellos* in (3c) will value and delete the ϕ -features of the participle, but will leave the Case feature of the noun unvalued. Since the noun remains active, it can then be probed by T and

get its Case feature valued. This interplay of feature matching and valuation/deletion via Agree is demonstrated in Figure 4.3 below, a simplified version of the derivation of *Ellos fueron encarcelados*. (Interpretable features are in bold, deleted features are crossed out):

Figure 4.3: Valuation and Deletion of Features (ex. *Ellos fueron encarcelados*)

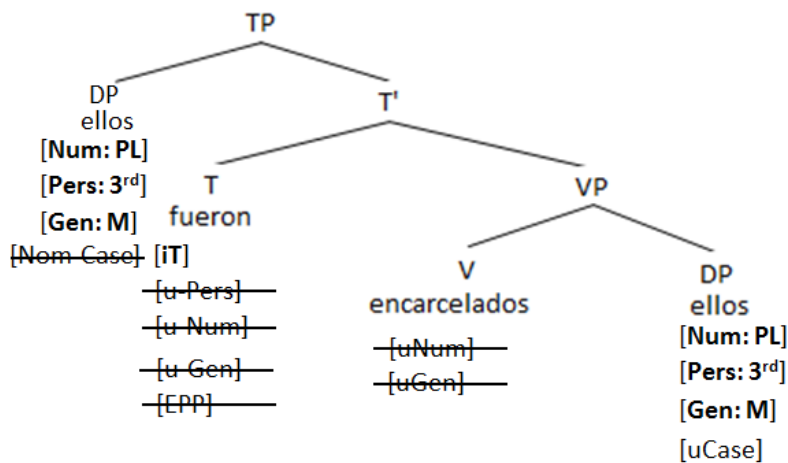

In Figure 4.3 above, the defective probe on the participle V enters the derivation with only two uninterpretable phi-features, for number and gender. Upon merger of the DP *ellos* ('they') with the verb phrase *encarcelados* ('incarcerated'), V probes the phi-complete DP and gets its phi-features valued and deleted. However, in accordance with the Completeness Condition in (6), the phi-incomplete participle cannot delete the uCase feature on the DP. Thus, the DP waits until the construction of the next phase up, including TP and T in Figure 3.3. T is phi-complete (by virtue of possessing both person and number features), and thus when it probes and Agrees with the DP below, it values the Case of *ellos* as nominative, deletes the LF-offending Case feature, and attracts the DP to [Spec, TP] via its EPP feature.

In the participle example in (3c), the probe on the participle is defective, since it lacks the person feature. Crucially, however, defectiveness is not limited to probes associated with verbal participles. It can also be a feature of phase heads in Raising and ECM constructions in (7):

- (7) a. Einstein parece tener la razón.
Einstein seems have._{INF} the reason
“Einstein seems to be right.”
- b. Yo vi al niño besar a su gato.
I saw the boy kiss._{INF} to his cat
“I saw the boy kiss his cat.”

In (7a) it is standardly assumed that ‘Einstein’ raises to the matrix clause to value its Case, and in (7b) that the cat-kissing boy must be in position to receive accusative Case from the higher clause. In the Principles and Parameters model, these structures were accounted for by positing an embedded clause that lacked a CP, a bare/raising IP. In Phase Theory, the P&P bare IP becomes a defective C-phase, also known as T_{def} , or C_{def} . In the analysis to follow, we will use C_{def} , since C is technically the locus of T’s tense and Agree features (Chomsky 2008: 143). C_{def} enters the derivation carrying no ϕ -features. One consequence of this is that the embedded C region no longer functions as a phase and is ‘transparent’ to the v^* phase above.

4.5 ECM Constructions in Phase Theory

Accordingly, in ECM constructions, matrix v^* can enter into an Agree relation with the embedded subject in [Spec, v^*P], assigning it structural accusative Case. One question that emerges here with regard to the derivation of (8) is whether or not to move *al niño* from its theta-position. In the Principles and Parameters framework, agreement was only licensed in a local

configuration (e.g., spec-head). However, with the advent of Minimalism and Phase theory, Agreement can occur without overt movement of lexical items (cf. Chomsky 1995b: 262), and thus the subject DP *al niño* can stay *in situ*, agreeing with the higher v^* probe via Long Distance Agreement (LDA). This derivation is sketched out in Figure 4.4 below for example (7):

Figure 4.4: ECM *in situ* (ex. *Yo vi al niño besar a su gato*)

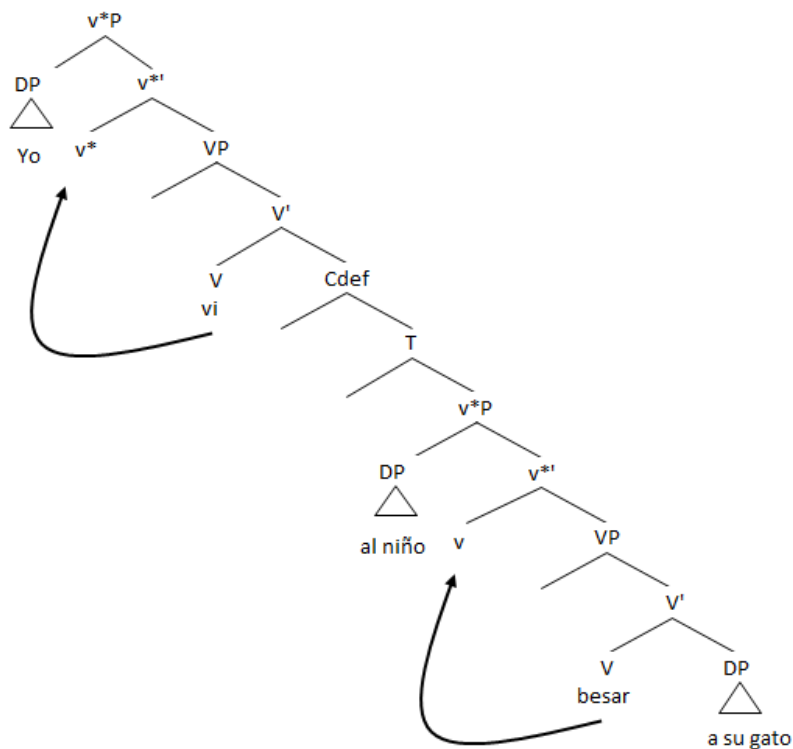

As was assumed under the dominant approach to ECM constructions in the Principles and Parameters framework, the embedded subject in the derivation in Fig. 3.3 receives objective Case from the higher governing verb, but remains *in situ*. However, there is now a considerable amount of evidence in favor of the idea of raising to object in ECM constructions, thanks to the pioneering work of Lasnik and Saito (1992) and Koizumi (1993, 1995) who reformulated earlier accounts of the operation into a modern framework. Raising to object can account for a variety

of constructions, such as those in (8), where the ECM clause is followed by an adverbial or prepositional expression which modifies the main-clause verb:

- (8)
- a. John made him out to be a fool.
 - b. The DA will prove the witness conclusively to have lied.
 - c. I have found Bob recently to be morose.
 - d. I've believed Gary for a long time now to be innocent.

(Radford 2009: 398)

If the underlined expressions in (8) are contained within the main-clause VP by virtue of modifying a projection of the main clause verb, then the accusative subject of the infinitival complement must also end up inside the main clause-VP. This is possible if the subject of the lower clause raises to an object position within the main clause. In Chomsky's most recent work (2008, 2013), he embraces the raising to object analysis for ECM and relates such a movement to feature Inheritance. He argues that the matrix Root V inherits phi-features from v^* and then can attract the embedded subject to [Spec, VP]. Under these assumptions, raising to object becomes an important piece of the Inheritance puzzle and adds to the explanatory power of Phase Theory: Inheritance is symmetric, affecting both phase heads C and v^* equally. Not only does T inherit agreement features from its Phase head C, but V also inherits features from phase head v^* . The raising approach to ECM is sketched in Fig. 4.5:

Figure 4.5: Raising to Object in ECM Constructions

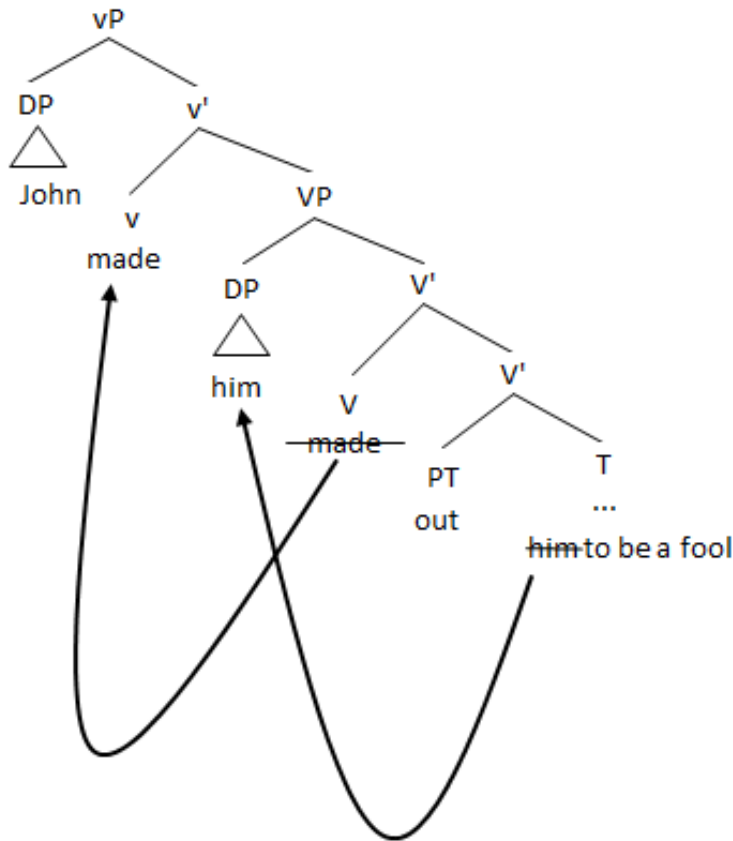

In Figure 4.5, the Root V of the ECM predicate first inherits agreement features from the phase head in v. V then probes, finds *him* in the subject position of the complement. The pronoun values the uninterpretable phi-features of V, and V values the Case of the embedded subject as accusative. Because of an EPP feature on V (inherited from v*--see the next section on Inheritance), *him* then moves to its 'Case position' in [Spec, VP], above the Root verb and the verbal particle *out*. Subsequent movement of the Root to the light verb, as in V-v head raising, yields the correct final word order, *John made him out to be a fool*. In Chapter 5 we will see how the configuration in Figure 4.5 is necessary in Spanish when the embedded subject argument is a clitic. In Spanish ECM, the embedded subject, as well as the embedded object, may raise to the matrix clause, as long as those elements are clitics.

4.6 Feature Inheritance

Raising to object is made possible in Phase Theory by the postulated operation of Feature Inheritance. The idea behind Feature Inheritance comes from Chomsky's (2008) observation that for T, agreement features appear to be derivative, not inherent. He contends that these features are actually determined by C. Accordingly, T only takes the basic features if it is selected by C. Otherwise, it is a raising (or ECM) infinitival, lacking ϕ -features and basic tense (Chomsky 2008: 143). Observe the contrast between the complement clauses bracketed below in (9):

- (9)
- a. It would seem [_{CP} [_C that] [_{TP} he [_T has] left]]
 - b. *He would seem [_{CP} [_C that] [_T [to] have left]]
 - c. * He would seem [_{CP} [_C Ø] [_T [has] left]]
 - d. He would seem [_{Cdef} Ø [_T [to] have left]]

In (9a), the embedded TP is selected by the C-constituent *that*, and the head of TP, T, carries a complete set of person/number agreement features, exemplified on the auxiliary *has*. By contrast, the embedded clause in the raising structures in (9b) and (9c) cannot be introduced via a complementizer or carry a complete set of agreement features. This result, Chomsky argues, is due to the fact that the infinitival complement is defective by virtue of lacking a CP, and the features that it carries with it into the derivation. He concludes that the agreement features of T originate on C, and subsequently get handed down to the T constituent immediately below C. The idea of putting ϕ -features on C is supported by languages with complementizer-subject agreement, like West Flemish:

- (10) a. Kpeinzen *dank ik* morgen goan

I.think that._{1.SING} I tomorrow go._{1.SING}

“I think that I’ll go tomorrow”

b. Kpeinzen *daj gie* morgen goat

I.think that._{2.SING} you tomorrow go._{2.SING}

“I think that you will go tomorrow”

c. Kpeinzen *dan* Valère en Pol morgen goan

I.think that._{3.PLUR} Valère and Pol tomorrow go._{3.PLUR}

“I think that Valere and Pol will go tomorrow”

(Haegeman 1992: 47).

In the West Flemish examples in (10), both C and T inflect for subject-agreement, lending credence to the claim that C has agreement features. The sentences in (10) also support the idea that feature Inheritance is sometimes a copying operation, in which C’s agreement features are copied onto T. Having made a case for feature Inheritance from C to T, Chomsky goes on to conclude that transmission of the Agree feature should be a property of phase-heads in general, not just C. Hence, v^* should transmit its Agree feature to V (Chomsky 2008: 148). This last assumption has implications for a theory of clitics in Spanish, in which, to accommodate the right movement and ordering of both accusative and dative clitics in a cluster, there must be a mechanism in place whereby the verb can abstractly Agree with both. As we explain in detail in Chapter 4, feature Inheritance allows first V and then v to attract clitics, via Agree and head-to-head incorporation. Each instance of Agree renders a clitic inactive, but the clitics nevertheless make it to T via sequential verb movements, i.e., through roll up of the complex head formed by verb and clitic movement.

However, we contend that even without the postulated operation of Feature Inheritance, our model of clitic movement goes through simply by assuming that V enters the derivation with a set of features of its own, in addition to those on v^* . That is, the Inheritance mechanism itself is ancillary to the assumption that V has agreement features with which to probe. And the evidence amassed in favor of raising to object by Postal, Lasnik, Saito, Kozumi and others supports this assumption. For the present analysis, nothing essential hinges on v^* being the original locus of said features. But before we get ahead of ourselves and present the particulars of our analysis, we must discuss the leading assumptions regarding locality in Phase Theory, since locality effects in part necessitate the feature Inheritance approach we advocate.

4.7 Impenetrability and Intervention Effects

Since Ross (1967), researchers in generative grammar have been interested in syntactic configurations where the movement of a constituent is blocked by an intervening structure, dubbed by Ross as an ‘island.’ Observe what happens to the sentences in (11) when we attempt to move the constituent *John’s book* in the cleft constructions in (12):

- (11) a. [Reading John’s book] is a chore
b. Bill attacked Mary [because she had not read John’s book]
c. Bill met a woman [who had not read John’s book]
- (12) *It is John’s book that [reading ___] is a chore
*It is John’s book that Bill attacked Mary [because she had not read ___]
*It is John’s book that Bill met a woman [who had not read ___]

(Rizzi 2013: 171)

In the above cases, the movement of *John's book* in the cleft construction is sharply deviant. Ross demonstrated that a number of syntactic configurations, such as those in (12), are impervious to movement rules. The key consideration in delineating islands is the structural quality of the configuration, not the mere quantity of words separating the terms of the dependency. The general formulation of Ross's island constraints can be expressed as follows in (13) (cf. Rizzi 2013: 172):

(13) Impenetrability: In the configuration

...X...[α ...Y...]

Movement cannot connect X and Y, for α = sentential subject, adverbial clause, relative clause...

Ross took the first step in discovering the phenomenon of islands and then providing the first catalogue of island environments. Chomsky (1973) undertook the task of subsuming Ross's catalogue of islands into a more abstract characterization. Chomsky's Subjacency principle (1973) was an early attempt at this project, followed by the concept of Barrier within Principles and Parameters (Chomsky 1986), and then finally, in the terms of Phase Theory, impenetrability is expressed formally in the Phase Impenetrability Condition (PIC). Recall that the PIC shortens the possible distance between dependencies in grammar to consecutive phase heads—the probe on a phase head can search no further than the next phase head down.

A second, and independently studied concept of locality within generative grammar is intervention, which occurs when a local relation fails across an intervening element. In addition to search constraints imposed by the PIC, intervention effects will also figure crucially in our analysis of clitic movement, to be laid out in full in Chapter 4. It is thus worthwhile to briefly consider how the notion of intervention has evolved and how we have arrived at our current

understanding of the phenomenon. The idea of intervention was originally introduced as the Minimal Distance Principle, and was discovered in a domain distinct from movement, control.

Consider the placement of PRO in a sentence like (14):

- (14) John told Bill [PRO to go]

We understand this sentence to mean that Bill is the one who will go, not John. In early accounts of control, it was thought that the subject of the matrix clause could not control PRO in (14) because of the intervention of a potential controller, the object *Bill* (cf. Rosenbaum 1967, Chomsky 1969). In more recent decades, intervention has been clearly and definitively addressed as a source of locality effects on movement, starting most notably with Rizzi (1990), whose principle of intervention is reformulated in a simplified manner in (15):

- (15) Relativized Minimality: in the configuration

...X...Z...Y...

X and Y cannot be connected by movement (or other local relations) if Z intervenes between them, and Z is of the same structural type as X.

(Rizzi 2013: 172)

The term ‘minimality’ here is used to express the fact that movement and other local relations must be satisfied in the smallest structural configuration possible. Observe how the principle of Relativized Minimality works in (17), when we question the statements in (16), and yield a *wh*-island effect in (17b):

- (16) a. I think [John left at five].
b. I wonder [who left at five].

- (17) a. When do you think [John left___]?
b. *When do you wonder [who left___]?

According to the Relativized Minimality (RM) approach, the ill-formedness of (17b) is due to intervention of the *wh*-element *who* between *when* and its trace. Since *who* is of the same structural type as *when* (they are both +*wh*-elements), RM applies and the movement of *when* over *who* is ruled out. When the intervening element is a regular NP, like *John*, the *wh*-word moves readily to the matrix clause. Later formulations of Relativized Minimality observed that intervention effects are only triggered when the relevant elements are related hierarchically via c-command. For instance, in (18b), no intervention effect is observed since the intervening element *who* does not c-command the trace of *when*:

- (18) a. The uncertainty about who won dissolved at five.
 b. When did the uncertainty [about who won] dissolve ____?

There is no *wh*-island effect observed in (18b) because the intervener *who* is buried within the complex subject DP. As c-command does not apply, *who* is disregarded, and movement proceeds.

This notion of hierarchical intervention can be stated formally:

- (19) Z intervenes between X and Y when X c-commands Z and Z c-commands Y.

(Rizzi 2013: 173)

4.8 Relativized Minimality: From Positions to Features

In the first formulations of Relativized Minimality, the typology of movement was defined in very broad terms. It considered the basic types of movement, such as head movement, A-movement, and A'-movement, and assumed that intervention is relativized to the nature of the target position of movement. With regard to head movement, which targets a higher head position, researchers initially believed that an intervening head would count as an intervener. This was borne out in data such as in (20), where auxiliaries 'have' and 'could' are heads:

- (20) a. The guests could have left.
b. Could the guests ____ have left?
c. *Have the guests could ____ left?

The same idea was applied to A-movement, where it was predicted that movement of an argument DP would not be allowed to skip a subject position:

- (21) a. Everyone considers [[John] [a good doctor]]
b. John is considered [____[a good doctor]]
c. *A good doctor is considered [John____]

Under original RM assumptions, the presence of an intervening A-position occupied by *John* was what blocked the movement of the DP *a good doctor* to the higher clause. Finally, with regard to the *wh*-island effect observed above, early RM predicted that it was the fact that the intervening *wh*-word occupied an A'-position that blocked movement targeting the matrix CP:

- (22) a. I wonder [who left at five]
b. *When do you wonder [who left ____]

However, this early version of Relativized Minimality had to be revised when certain asymmetries with these configurations were discovered. It was observed that not all *wh*-elements are equally impossible to extract from indirect questions. Consider what happens when we make the indirect questions in (23) full questions in (24):

- (23) a. I wonder [how to solve this problem ____].
b. I wonder [which problem to solve ____ in this way]
- (24) a. Which problem do you wonder [how to solve ____ ____?]
b. *How do you wonder [which problem to solve ____ ____?]

The question in (24a) is much better than the clearly impossible (24b). It thus appears that for configurations like those in (24a), a so-called ‘weak island,’ the ban on A’-movement over an A’-position does not hold universally. A similar pattern arises in many other attested languages, including languages in which *wh*-elements are not overtly moved to the front, such as Chinese (Huang 1982). The existence of this asymmetry in language after language raises a problem for the position-based approach to locality expressed in early versions of Relativized Minimality, and has ultimately led to a reformulation of the principle.

It turns out that a key difference between the two sentences in (24) is that the extractable *wh*-question *which problem* is more richly specified in terms of features (+*wh*, +N) than the unextractable *how* (+*wh*). Michal Starke (2001) attempted to generalize this kind of observation, and developed the following intuition: a more richly specified element can be extracted from the domain of a less richly specified element, but not vice-versa.⁴ In the above example, *which problem* contains a lexical specification, the noun *problem*, while *how* is not lexically specified. Starke’s intuition is strongly supported by another well-studied asymmetric pattern in French. In the sentence in (25), the *wh*-operator *combien*, corresponding to *how many/how much*, can move to the initial periphery if it ‘pied-pipes’ the whole nominal expression it modifies, including the lexical restriction, as in *combien de livres*, or it can move alone, stranding the lexical restriction:

- (25) a. [Combien de livres] a-t-il consultés ____?
 how many of books has he consulted
 ‘‘How many books did he consult?’’
- b. Combien a-t-il consulté [____ de livres]?

⁴ Starke’s formulation of minimality here builds on the original discoveries of Huang (1982) regarding constraints on extraction domains (CED) and ECP effects.

how many has he consulted of books

“How many books did he consult?”

However, in cases of extraction from an indirect question, the whole object DP can be extracted, while the bare *wh*-operator cannot:

(26) a. ? Combien de livres ne sais tu pas comment consulter ____?

how many of books no know you not how to consult

“How many books don’t you know how to consult?”

b. *Combien ne sais-tus pas comment consulter [____ de livres]?

how many no know you not how to consult of books

“How many books don’t you know how to consult?”

(Rizzi 2013: 179)

As was the case with the English sentences in (24), the alternations from French show that an element that is more richly specified in terms of the features it carries into the derivation may move over an element that is less richly specified, but not the other way around. In (25) *combien de livres* is [+*wh*, +N] while *combien* by itself is just [+*wh*]. In the spirit of Starke’s proposal, Rizzi has reformulated the concept of Relativized Minimality:

(27) Relativized Minimality (revised): in the configuration

...X...Z...Y...

A local relation (e.g., movement) cannot hold between X and Y if Z intervenes and Z fully matches the specification of X in the relevant morphosyntactic features.⁵

⁵ As Rizzi (2013) points out in his summary of locality effects, RM is expressed as a representational principle, a constraint that must be satisfied by the configuration created by movement. In a derivational framework, where constraints apply directly to movement and the operation of ‘search’, such as in Chomsky (2000), RM is often referred to as ‘Minimal Search.’ Both can be subsumed within the larger umbrella term of ‘Minimality,’ which we will use as much as possible, since it does not crucially hinge on either strictly derivational or representational assumptions.

(Rizzi 2013: 179).

Thus, a potential intervener Z blocks a local relation when it is at least as richly specified as the target of the relation (X). The following visualization helps make this concrete:

(28) **Which problem** do you wonder [**how** to solve ___]?

[+Q, +N]	[+Q]	
X	Z	Y

(29) * **How** do you wonder [**which problem** to solve ___]?

[+Q]	[+Q, +N]	
X	Z	Y

In our proposed analysis of clitics, this formulation of Minimality will help explain the observed intervention effects with clitics and their doubles, especially in ECM constructions. By the end of Chapter 4, we will have shown how Relativized Minimality, in conjunction with the Phase Impenetrability Condition, accounts nicely for the intervention and island effects induced by clitic movement in Spanish. But first we must tie up loose ends and present a viable implementation of head movement in Phase Theory. For this, we first turn to Ian Roberts.

4.9 Head Movement in Generative Grammar

Recall that in the introduction to the present work, it was explained that the existence of head movement has recently been called into question by many researchers, spurred by comments made in Chomsky’s influential article “Derivation by Phase” (2001). Before we look at the substance of Chomsky’s remarks, we will offer a few comments about the trajectory of the idea of head movement. Head movement has featured prominently as a useful theoretical tool throughout the history of generative grammar. It played a central role in several foundational

analyses, including Affix Hopping in Chomsky (1957), McCawley's Tense-attraction rule (1971), Emonds's (1971, 1976) *have/be* raising and his (1978) verb movement rule for French. Yet as Roberts (2011) explains in his comprehensive summary on the current status of head movement in Minimalism, the idea of head movement really took off in the Government and Binding (GB) period, within the Principles and Parameters framework. It was then that the leading ideas regarding head movement were systematized and articulated clearly and concisely. Three works from this period stand out in this regard: Koopman (1984), Travis (1984), and Baker (1988). Summarizing their respective positions, we can characterize head movement simply in (30):

- (30) Head movement is the case of Move- α where α is X^0
(Roberts 2011: 196)

As an instance of Move- α , head movement was argued to be subject to the standard well-formedness conditions applying to movement operations. These conditions involved structure preservation, locality, and the requirement that the trace created by the movement operation meet the relevant conditions on traces. With regard to structure preservation, Chomsky (1986a) offers two conditions on head movement: “only X^0 can move to a head position” and “only a maximal projection can move to a specifier position” (4). He says this would follow “from an appropriate form of Emonds's Structure Preservation Hypothesis.” Later in this work, Chomsky rules out adjunction of heads to maximal projections—banning them from adjoining to heads in A-positions (73). This does not, however, rule out head-to-head adjunction (Roberts 2011: 197). In actuality, the take-away from Chomsky's theorizing is that head movement can only move a head to another head position in a minimal category. It was standardly thought that head movement adjoined the moved head to the host head, forming a structure like in (31):

- (31) [_Y XY]

Kayne (1991, 1994) further proposed that head adjunction is always left adjunction, as depicted in (31). With regard to locality, we have already seen that in early versions of Minimality there was a constraint that banned heads from moving over intervening heads. This idea as it applies to head movement was first explicitly characterized by Travis (1984) as the Head Movement Constraint (HMC). The HMC is given in simplified form in (32):

(32) Head movement of X to Y cannot skip an ‘intervening’ head Z.

(Roberts 2001: 113).

Another common assumption at this time was that the formation of a complex head could not be undone by a later step of movement. Hence further movement of Y to a higher head W would form the complex head $[_{w[Y XY] W}]$. This would mean that iterated head-movement always entails cyclic ‘roll-up’, forming a successively more complex head. Finally, in the GB period, the trace of head movement was subjected to the standard conditions on traces. This included the Empty Category Principle (ECP), which required all traces to be properly governed. One important effect of the ECP was that head movement out of an XP not contained in the structural complement of Y is impossible. Accordingly, Baker (1988) argued that head movement from subjects and adjuncts is impossible. Second, ‘downward’ head movement is not possible, since a fundamental requirement posed by the ECP is that an antecedent c-command its trace.

In summary, the GB conception of head movement was that it was a core syntactic operation raising a head X to an immediately governing head Y where X is contained in Y’s immediate structural complement. The effects of this conception of head movement were observed in a wide range of empirical phenomena, including noun incorporation, morphologically complex causative constructions, passives, verb movement of the Spanish/Romance kind, English-subject auxiliary inversion, Spanish/Italian Aux-to-Comp,

inversion of inflected infinitives in European Portuguese, clitic movement, movement to C in German and clause-initial position in VSO languages, among many others (cf. Roberts 2001).

In early versions of Minimalism the concept of head movement was retained. Discussion of V movement to T and AGR in Chomsky (1995b: 195-199) introduces checking theory, and makes it clear that V movement, like other forms of movement, obeys the core constraints of the theory. However, in Chomsky (2001), a series of arguments are presented that lead the author to conclude that “a substantial core of head-raising processes...may fall within the phonological component” (37). First, Chomsky argues that head movement does not affect interpretation: “the semantic effects of head-raising in the core inflectional system are slight or non-existent, as contrasted with XP-movement” (2001: 37). Roberts (2011) explains that this claim boils down to the fact that while French or Icelandic verbs occupy a different structural position in finite clauses from their English or Mainland Scandinavian counterparts, there are no LF-related differences between verbs, neither scope nor reconstruction effects, which one might expect when studying different types of head movement (199). As no such effects are found, it might make sense to confine head movement to the PF component of the grammar.

Chomsky’s second question about head movement involves the nature of the trigger for the operation in Phase Theory. This issue arises when we consider a language like French, which has consistent DP movement into [Spec, TP] and consistent V movement to T. For this to be possible, T must contain the relevant featural triggers for both movements: uninterpretable phi-features and EPP to trigger DP movement, and some form of V features plus movement triggering feature to force V movement. This suggests that the system must have sufficiently rich featural information to be able to distinguish between the two sets of triggers: for D and V.

Chomsky's point is that the movement-triggering mechanism needs to be enriched in such a way that head movement has a special kind of triggering feature.

Third, Chomsky claims that the derived structure of head movement in (31) is countercyclic, and as such, violates the Extension Condition. The Extension Condition requires that all movement operations extend the root of the derivation. For example, when a *wh*-element raises to form [Spec, CP] it extends the root at this point in the derivation. However, head movement derives structures such as those found in (31), by adjoining one head to another. Such an operation does not involve an extension of the root in an obvious way, at least without appeal to a special notion of 'root.' Fourth, owing to the fact that head movement adjoins one head to another, in the derived structure the moved head is unable to c-command its trace/copy. This is true only if we maintain the usual definition of c-command: the transitive closure of sisterhood and containment (Roberts 2011: 200). If we adopt the kind of definition assumed by Kayne (1994: 18), which allows an adjoined category to c-command both the category to which it adjoins to and out of that category, then the moved head would be able to c-command its trace in a typical head movement configuration, like in (33):

$$(33) \quad [_{YP} \dots [_{Y} XY] \dots [_{XP} \dots (X) \dots]]$$

Fifth, and finally, Chomsky argues that head movement is suspect as a core-syntactic operation since onward cyclic movement is never successive-cyclic. Instead it involves 'roll-up.' We mentioned this before, as it was standardly assumed that iterated head movement forms a successively complex head. Successive-cyclic movement, on the other hand, would involve excorporation of X from [_YXY], moving X on to form [_wXW]. Even though Roberts (1991) predicted that this successive-cyclic type of excorporation exists, the general view remained that this is not attested to empirically. In a system without excorporation, Roberts contends, it would

be necessary to explain why successive cyclic movement is not available for head movement, while it is so clearly available for phrasal movement.

Chomsky's arguments gave rise to a variety of reactions. In general, they have been influential, as many researchers have been led to look for alternatives to the earlier approach of head movement. These include operations such as PF movement (a morphological operation), remnant phrasal movement (where the head in a category does not move, but everything else may), and 'reprojective' movement (where head movement is syntactic, but follows from a different set of conditions than XP movement). However, as Roberts notes, despite the fact that Chomsky's arguments against head movement naturally led to a reevaluation of the relevant phenomena, Chomsky himself has not articulated a theoretical principle which would force, either directly or as a deductive consequence, the elimination of head movement from the narrow syntax (2011: 201). Furthermore, Roberts questions whether eliminating head movement, and replacing it with potentially more complex and less intuitive types of operations, is really the best way proceed given the Strong Minimalist Thesis (SMT) that is meant to guide researchers within the Minimalist Program, in (34):

(34) Language is an optimal solution to legibility conditions.

(Chomsky 2000a: 97)

One way to satisfy this hypothesis would be to assume that internal merge (IM) and external merge (EM) are identical, except for the irreducible difference of what defines them, i.e., IM takes place within a structure in the process of construction while EM introduces the element to be merged from the outside. Optimally, this would remain the only difference—to yield the simplest type of computational system possible. Roberts argues that since EM is already uncontroversially applicable to heads (i.e., single lexical items or feature bundles), there needs to

be a very good reason to treat IM in a different way. If head movement is absent altogether, or restricted to the PF interface, then there must be an explanation of this in terms of what else distinguishes IM from EM (Roberts 2011: 218). Instead of abandoning classical head movement, Roberts proposes that we reformulate it in such a way that conforms to current assumptions regarding structure preservation, locality, and well-formedness conditions on traces. Like Roberts, we prefer to retain the core intuition of head movement, and are amenable to the idea that in a perfect system IM and EM employ the same computational principles. As we will see with clitic movement in ECM constructions, it is necessary to preserve the notion of head movement in complex structures in which clitics can raise to object, but maximal phrases cannot.

4.10 A Phase-Theoretic Implementation of Head Movement

To make the case for retaining head movement, Roberts (2010a) begins with the claim that head movement lacks semantic effects observed with other types of movements, and as such, is an aspect of the interface between narrow syntax and the operations that derive PF representations. Although Roberts does not deny that there may be cases of PF head movement (such as subject procliticization in French), he makes the case that head movement is not exclusively a PF-operation. To do so, he cites an instance where head movement has an effect on the semantic component-- where it interacts with what are usually taken to be LF operations. One such instance of head movement with LF-effects involves subject-auxiliary inversion, which is standardly seen as T-to-C movement. The relevant examples are questions where a negative auxiliary element *doesn't* moves to license a polarity-item subject.

As we observed with the licensing of negative polarity items with datives in Chapter 1, polarity items such as *anyone*, *anything*, are dependent on expressions that contain a special

element to license them in the same syntactic domain. As we saw with the double object and prepositional dative examples, the licensing element must c-command the polarity item at some point for the expression to be well-formed. In the sentences in (35) and (36), the subject polarity item needs to be c-commanded by a negative auxiliary to be licensed⁶:

- (35) a. *Which one of them does anybody like?
b. Which one of them **doesn't** anybody ____ like?

(Roberts 2010a: 10)

- (36) a. *I know why anyone didn't help us.
b. Why **didn't** anyone ____ help us?

(Kayne 2000a: 44)

- (37) a. *They succeeded in finding out which one of them anybody **didn't** like.
b. They succeeded in finding out which one of them **wasn't** liked by anybody.

(Roberts 2010a: 10)

The starred example in (37a) shows that where there is no subject-auxiliary inversion—like in an embedded question—the subject polarity item fails to be licensed, since it is not c-commanded by the negative auxiliary in T. (37b), however, shows that passivizing the expression, and thus placing the polarity item in a *by*-phrase in a position c-commanded by the negation in T, yields a grammatical case of polarity-item licensing. As for the good examples in (35b) and (36b), Roberts convincingly argues that negation is raised to C with the auxiliary, and that this operation must be syntactic because it affects LF. If it is head movement, then there is syntactic

⁶ Roberts explains that polarity-licensing must be an LF-condition since it appears to be a condition on the polarity-item interpretation of *any*. There are some contexts where the polarity-item interpretation is not allowed while the free-choice interpretation is (e.g., *Any doctor can tell you that fun is bad for you*), thus licensing polarity *any* is presumably determined by LF- rather than PF-conditions (2010a: 9).

head movement.⁷ Roberts goes on to show that head movement is broadly comparable to A-movement in its LF-effects. In addition to polarity-licensing, Roberts cites examples where head movement entails interpretive effects with scope and reconstruction.

Roberts then attempts to address Chomsky's observation that a special and highly restrictive locality condition on head movement (HMC) is suspect. Roberts agrees that the HMC makes head movement seem too different from XP-movement. However, instead of interpreting the HMC as an argument against head movement, Roberts contends that there is actually no need for the HMC. After a thorough analysis of constructions involving apparently 'long' instances of head movement, such as 'long verb movement' and 'predicate clefting', Roberts concludes that head movement is only constrained by Agree and the PIC, no different from XP movement. This means that there are cases of head movement where a head 'skips' an intermediate head. As long as this takes place between consecutive phase heads, and as long as the non-intervention requirement on Agree is satisfied, long head movement is allowed (2010a: 193). This is what we predict with our own analysis of clitic climbing in ECM constructions. As we will argue, the embedded subject clitic in [Spec, v*P] can move as a head to the higher finite v*-head to receive dative Case, skipping the intermediate head positions of T and matrix V.

In support of his claim against the HMC, Roberts cites cases of 'Long Verb Movement' (LVM) constructions in Breton, a Celtic language spoken in Brittany. Through a detailed and careful series of arguments showing that Breton LVM is V-movement, and not VP-fronting as in German (194-198), Roberts demonstrates that Breton LVM is a genuine case of long head movement of a nonfinite verb. In Breton, V moves into the C-system, as in the sentence in (38), and its tree-diagram derivation in Figure 4.6:

⁷ For further examples of semantically active head movement, see Lechner (2005).

- (38) Lennet en deus Yann al levr
 read.PPRT⁸ has Yann the book
 “Yann has read the book.”

Figure 4.6: Long Verb Movement in Breton

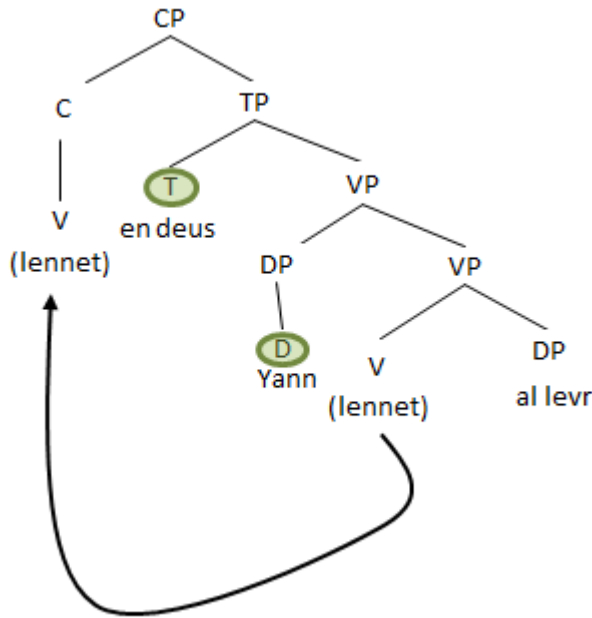

As we can see clearly in Figure 4.6, V skips two intermediate head positions on its way to C—it skips D of the predicate internal subject *Yann* and it skips the auxiliary *en deus* in T, before settling in C, where it is pronounced. If Minimality is computed with regard to features instead of positions, then this result follows readily. Since the intervening D and Aux features are different from (thus not identically specified as) V, they do not block the long movement of the verb.⁹

⁸ PPRT= past participle

⁹ Although both are verbs, Aux is not as richly specified as V in this example if V contains an additional focus feature. In the predicate-clefting examples in Spanish in (40) and (41) this is borne out, as the infinitive can be independently focused in Spanish, but not the auxiliary. This same pattern was shown for V-to-C movement in Vata, by Koopman (1984). This was the construction earlier cited in this work as an example of a language which phonetically realizes the trace copy of verb movement.

Furthermore, the triggering probe for LVM is C, which can see the verb in v* and attract it, hence the relevance of the PIC—V is visible and hence ‘penetrable’ to C in Figure 4.6.

A similar example comes from Spanish and other languages with a configuration known as predicate clefting. Predicate clefting is an operation which places a verb in clause-initial position, with a phonetically realized copy of the verb in clause-internal position. It is found in many African languages, creoles, Hebrew, Hungarian, and, at least colloquially in certain Romance languages (Roberts 2010a: 199). Predicate-clefting includes the sentence in (39):

(39) a. *Comprar*, Juan ha comprado un libro.

buy._{INF}, Juan has bought a book

“As for buying, Juan has bought a book”

(Vicente 2006: 44)

This displacement can span intermediate heads, and even show island effects, further evidence in support of movement (Vicente 2007: 79-81):

(40) *Long Distance*

a. *Comprar*, Juan ha dicho que María ha comprado un libro.

buy._{INF}, Juan has said that María has bought a book

“As for buying, Juan has told me that María has bought a book.”

b. *Complex NP Island*

**Comprar*, ha oído el rumor de que Juan ha comprado un libro.

buy._{INF}, Juan has heard the rumor that Juan has bought a book

“As for buying, I heard the rumor that Juan has bought a book.”

c. *Adjunct Island*

**Comprar*, he ido al cine después de comprar un libro.

buy._{INF} I have gone to the cinema after of buy-INF a book

“As for buying, I have gone to the movies after buying a book.”

Vicente (2007: 85-105) argues that the Spanish predicate-cleft construction is V movement, not VP remnant movement. He claims there is no plausible mechanism for evacuation or deletion of the VP material. Accordingly, predicate-clefting in this construction should involve long movement of the infinitive from v* to C, over the finite form of the auxiliary *haber* ‘have’. Along with Breton LVM, this would amount to an A’-species of head movement. This is good news for a syntactic account of head movement, as it indicates yet another parallel with XP-movement, which obviously employs both A- and A’-movements.

The possibility of ‘long verb movement’ in languages like Spanish is nicely mirrored by ‘long D’ movement of clitics (long A-head movement). Recall from our discussion of the conditions on clitic climbing in Chapter 1 that in sentences with multiple auxiliaries, clitics must often cross intervening forms, since they cannot attach to past participles:

- (41) a. Juan **lo** había estado cantando.
Juan it._{ACC.MASC} had been._{PPRT} singing
“Juan had been singing it.”
- b. *Juan había **lo**-estado cantando.
Juan had it._{ACC.MASC} been._{PPRT} singing
“Juan had been singing it.”
- c. *Juan había estado-**lo** cantando.
Juan had been._{PPRT} it._{ACC.MASC} singing
“Juan had been singing it.”
- d. Juan había estado cantándo**lo**.

Juan had been._{PPRT} singing it._{ACC.MASC}

“Juan had been singing it.”

In the sentences in (41), the clitic cannot attach, proclitically or enclitically, to the past participle *estado* (‘been’). This suggests that the incorporation of the clitic to the finite auxiliary *había* ‘had’ in (41a) involves long distance clitic movement across the head position occupied by the participle. Once again, this movement proceeds unproblematically in accordance with Relativized Minimality if one assumes that the clitic carries a Case feature (D-feature) not found on the infinitival verbal forms it crosses on its way to the agreeing finite verb that values its Case, as we propose in Chapter 4¹⁰.

As there is not sufficient space to transcribe Roberts’s entire argument in favor of syntactic head movement, we will stop here with the detailed summary of his claims. However, a few more brief comments are in order, before we consider how his approach to clitic head movement diverges from our own. It is important to note that Roberts does tackle Chomsky’s other concerns with head movement, namely that it is not structure preserving, nor sufficiently motivated by the feature inventory of the relevant probes. Regarding the Extension Condition, Roberts notes that this does not need to be formulated as an independent condition in Chomsky’s more recent work (cf. 2008), but instead derives from Edge Features (EF). As a result, there are cases of head movement that satisfy it, such as long verb movement and predicate clefting, while there are other instances of head movement, like standard verb movement, that do not. However, this asymmetry is also observed with XP-movement, since in Chomsky (2008) A’-movement is triggered by EF and thus obeys the Extension Condition, while A-movement is not and does not

¹⁰ As we will explain shortly, we differ with Roberts regarding the feature content of clitics. While we put a Case feature on clitics and consider them D(eterminer) elements, Roberts conjectures that they lack Case, and are thus of the category ϕ , indicating that they are composed only of phi-features.

(148-150). In other words, if the phase is built before EF and Agree operations take place, then movements that do not target phase-heads are not targeting the root of the derivation.

With regard to the nature of the trigger for head movement, we saw that it can be EF, as in long verb movement, or Agree, as in clitic movement to the front of a finite verb. Thus, head movement can be triggered by the same elements that trigger XP-movement (Roberts 2010a: 213). Finally, the claim that head movement always involves ‘roll-up’ is also not true, according to Roberts, whose analysis allows for excorporation, which is successive-cyclic.¹¹

Ultimately, the picture that emerges from Roberts’s analysis is that of a more unified and elegant theory of movement. Under his approach, movement becomes more general, with no distinction between minimal and maximal categories, in the spirit of bare phrase structure. With syntactic head movement, there is no need for a stipulation that Goals pied-pipe their maximal hosts. Finally, and most importantly, the possibility of head movement makes Internal and External Merge as alike as possible, differing only in the origin of the merged element. As he concludes, “the burden of proof, then, lies in showing on the one hand there are no attested cases of syntactic head movement and on the other that a theory of movement that cannot express this possibility is conceptually simpler than the one put forward [here]” (Roberts 2010a: 216).

4.11 Clitic Movement without Case?

Although we are clearly inspired by the account sketched by Roberts, and find his arguments in favor of syntactic head movement appealing, we do diverge from his approach in

¹¹ For detailed arguments in favor of excorporation, see Roberts (2010a: 75-90), and for the details of how minimal elements can be merged and moved in such a way that is structure-preserving, see Roberts (2010a: 50-64). His impressive implementation of these concepts is too intricate and involved to summarize here, but the main point is that, at least from our perspective, he manages to successfully address Chomsky’s concerns with head movement as a syntactic operation. Also, it seems worth pointing out that despite his critical comments, Chomsky still appears to believe in at least one type of head movement, and that is V-to-v movement, which is crucial for his implementation of raising to object in ECM constructions (cf. Chomsky 2013). Without movement of the Root to v*, the observed word order in sentences like *John made him out to be a fool* does not obtain.

some of the specifics related to clitics. The most significant point of divergence regards the categorial status of these elements. In his thorough discussion of Romance cliticization Roberts (2010a: 41-155) analyzes cliticization as head movement. Following Kayne (1975), Roberts assumes that the clitic is an argument of the verb, and as such, moves to its derived position as a reflex of agreement. We agree with him on these points. Furthermore, we accept his postulation that clitic movement targets features on v^* , the probe head in Phase Theory that is the original locus of structural accusative Case assignment (2010a: 50). Here we differ from his account by first adjoining the DO clitic to V, not v^* ¹², but we concur that the clitic ends up in the verbal phase head, from which it moves onto to T in languages like Spanish and Italian.

More significantly, we disagree with Roberts when he assumes, following Cardinaletti and Starke (1999), among others, that clitics lack Case features. Although he begins his analysis with the intuitive (and we believe correct) idea that clitics, as nominal arguments, are of the category D, he ultimately ends up postulating clitics as Caseless, ‘ ϕ Ps.’ In his account, clitics are specified for phi-features (hence ‘ ϕ ’), but lack a D feature (Case). To be clear, Roberts believes clitics are nouns, but that they lack the defining characteristic of nouns in syntactic theory—Case. From our perspective, this move deviates from Roberts’s generally elegant and unifying approach. In our view, the same approach should be taken toward clitics as he takes toward head movement. Again, clitics have phi-features, trigger intervention effects, and cannot move freely beyond an agreeing finite verb. These are all hallmarks of nouns—and, as we have argued, it is conceptually more elegant and in line with SMT expectations to incorporate clitics into the nominal domain, rather than posit special mechanisms and categories for them. Basically,

¹² This is made possible by the inheritance of Case assigning features by V from v^* . Roberts (2010a) does not consider this possibility, even though he accepts feature inheritance on the C-phase, evidenced in his *v*-to-T analysis for verb movement.

Roberts needs to make clitics Caseless to allow for his version of incorporation to take place—however, we believe much of his model can be adopted with a few small modifications.

In Roberts's account, head movement is only licit when the goal element contains a subset of the features on the probe that attracts it. He refers to heads that move by themselves as 'defective goals'—they are defective in the sense that they do not have any features which distinguish them from their matching probe. This allows head goals to share the same label as the head to which they adjoin, assuming that labels are projected based on the feature content of the items being labelled. He formalizes his notion of defective goals in the following ways, first in (42) and then later in (43):

- (42) Incorporation can take place only where the label of the incorporatee is nondistinct from that of the incorporation host.

(Roberts 2010a: 57)

- (43) A goal G is defective iff G 's formal features are a proper subset of those of G 's Probe P .

(Roberts 2010a: 62)

Since the label of v^* contains phi-features—in fact, unvalued versions of the phi-features that make up the clitic—the clitic's label is nondistinct from v^* 's. This allows the clitic to adjoin to v^* and form a derived minimal head, which projects the label v^* upon merger (2010a: 57). One of the main reasons that Roberts cites in assuming that clitics are Caseless is due to the common assumption that verbal probes lack Case features. This assumption is largely due to Chomsky's conjecture that structural Case is not a feature of probes (T, v), but is assigned a value under agreement (2001: 6). Accordingly, Roberts, with many others, assumes that structural Case assignment occurs as a 'reflex' of agreement in phi-features between nominal goal and verbal

probe. If v^*/V don't have Case features, Roberts cannot put a Case feature on the clitic, as the clitic would no longer contain a proper subset of the verbs' features.

This can be circumvented though, if v^* is allowed to enter the derivation with a Case feature. The idea of structural Case assignment being assigned by 'reflex' is vague, and in our opinion, not a compelling reason to deprive clitics of Case. In any event, we find it conceptually more parsimonious to assume that Case is valued via a match of features on goal and probe, in parallel with phi-features. To assign accusative Case for example, we would add an uninterpretable (but valued) +ACC feature on the agreeing probe V (inherited from v^*), that gets deleted in the process of valuing the u Case feature on the goal. The goal's Case feature is deleted as well, in line with the assumption that all uninterpretable features get deleted upon Transfer.

Consequently, adding a Case feature on v^* actually enables us to adopt Roberts's implementation of head movement, where the goal's features are contained in the probe. Incorporation can go through then in accordance with Roberts's definition of Defective Goals in (43), and no problems are posed for the labeling mechanism. This would also solve another problem with Roberts's account, namely that making clitics of the category ϕP does not allow them to be 'frozen' in place by the Activity Condition. This was observed by Boeckx and Gallego (2008), who, in line with our assumptions, posit clitics as Ds.¹³ They point out that clitics, as Ds, are subject to the Activity Condition. That is, once they are valued for Case, regular nouns become inactive and ineligible to participate in further syntactic operations. This is observed with clitics in Romance languages—they cannot move beyond a finite clause. In

¹³ Although we don't go into too much depth here about the proposal of clitic movement offered in Boeckx and Gallego (2008), we are greatly indebted to these authors for their arguments relating clitic movement to Agree and Case valuation. We concur with them in many of the relevant details, including the motivation for clitic movement, as well as its biclausal nature in CC environments. The main area where we deviate from their approach relates to the issue of head movement, which they disavow for some of the reasons cited in Chomsky (2001). They postulate cliticization as the result of XP movement—a possibility we will specifically argue against in Chapter 4, when we discuss clitic movement in ECM structures in Spanish.

Roberts's account, however, there is no such principle to constrain the movement of clitics, and hence no mechanism to filter out movement of the clitic to the higher finite clause in (44), reproduced from the examples on barriers to clitic climbing in Chapter 1:

- (44) *Yo lo quería que Pepe hubiera querido hacer.
I it._{ACC-MASC} wanted that Pepe had wanted do._{INF}
'I wanted Pepe to have wanted to do it'

As we can see in (44), the valuation and deletion of the clitic's Case is tied to the finite verb *hubiera* ('had'). The probe on *hubiera* must delete the Case feature on the clitic, and render it inactive, in order to prevent further clitic climbing.

Other areas where we deviate from Roberts's account of clitic movement include three issues that we have already covered in depth. First, Roberts considers the dative clitic to be a 'morphological reflex' of a functional head called an applicative (cf. Collins 1997, Anagnostopoulou 2003, Pylkkänen 2008), instead of being the direct object pronoun itself. We argued in Chapter 1 that the dative clitic, although semantically associable with a larger set of doubles than its DO counterpart, including pure indefinites, is nevertheless similar to the accusative clitic in other ways. For instance, not only did the IO and DO clitics evolve similarly from Latin stressed pronominal forms, but in Spanish the dative clitic's double must always obey Kayne's Generalization (in all recorded dialects), making it an even stronger candidate for a verbal Case-absorbing argument than the DO clitic, which can appear with doubles un-introduced by the Case morpheme *a* in many dialects. Furthermore, recall, the dative clitic is the mandatory dative argument in Spanish double object constructions, based on the findings of Demonte (1995) and Masullo (1992). The IO double, however, is optional, as we would expect it to be under an adjunct analysis of the double, such as in the present study. Once again, at least

descriptively, Spanish does not permit null objects in expressions involving IOs. They must surface in pronunciation, and the mandatory presence of the dative clitic in double object constructions is strong evidence of the argument status of these elements. Finally, recall that the dative clitic climbs in the same cyclic fashion as DO clitic, and must climb with it to higher clauses, which we would not necessarily expect to be the case if the clitics belonged to different categories of elements. Furthermore, the IO clitic is sensitive to many of the same types of intervention and impenetrability effects as DO clitics, such as *+wh*-islands. All of these facts point to the equal status of DO and IO clitics as pronouns.

The second area where we deviate from Roberts is in his adoption of a Cinque-style mono-clausal approach for clitic climbing. Although we acknowledged in Chapter 1 that the monoclausal approach seems to be on the right track for functional embedding verbs (i.e., auxiliaries), we find it unconvincing for cases where the embedding verb is lexical, especially in clitic climbing in ECM-style perception verbs and causatives. We previously discussed in Chapter 2, in section 2.7, how a monoclausal approach does not explain how three clitic arguments can be licensed for structural objective Case by a single-agreeing verb, assuming that there is only one accusative Case slot available to a single predicate in (45a). Nor can it explain where the verb moves to in cases of inversion of the embedded infinitive in examples like (45b), where T_{def} seems to be a natural site to host the inverted verb. The presence of T, however, signals the presence of two clauses. Finally, biclausality explains why an anaphoric reflexive clitic cannot move to the higher clause, even with inversion of the verb in (45c):

- (45) a. Lo hice escribírselo.
 him.ACC.MASC I made write.INF her.DAT lo.ACC.MASC
 “I made him write it to her.”

b. Pedro se lo hizo leer a Juan. (lo= *el libro* ('the book'))

Pedro him.DAT it.ACC.MASC made read.INF to Juan

“Pedro made Juan read it.”

c. *Juan se_i hizo [afeitar a los muchachos_i t_{se}]

Juan SE.REFL made shave.INF to the boys

“Juan made the boys shave themselves.”

Remember that (45c) is OK if the clitic surfaces enclitically on *afeitar*. Hence the ungrammaticality of (45c) does not result from the movement of the anaphoric clitic above its antecedent *los muchachos* ('the boys). Rather, (45c) is out because the anaphor *se* is bound within the clausal domain of its antecedent, and hence cannot move higher than T_{def}.

Finally, we depart from Roberts's otherwise convincing analysis in the derivation of dative arguments generally, and not just dative clitics. As we mentioned above, Roberts assumes that all dative arguments are generated with the help of functional categories called applicatives (i.e., vappIP). The applicative approach was most famously applied to Spanish indirect objects by Cuervo (2003). Although Roberts follows Cuervo in base-generating dative clitics as agreement morphemes in the functional applicative head, he diverges from her by moving dative clitics from their base-generated position. We outline a derivation of IO-DO clitic clusters in simple sentences such as *Se lo dio* ("She gave him it"), based on the structures utilized in Roberts's approach (2010a: 138-140), in Figure 4.7¹⁴:

Figure 4.7: Derivation of IO-DO Clusters with the Applicative

¹⁴ Although Roberts posits clitics as ϕ -elements, we label them as 'D' in Fig. 3.6, in line with our own assumptions. Also, note that in Figure 3.6 the dative clitic is depicted as *le*, as we assume that post-syntactic, morphological processes are responsible for spelling out the third person IO clitic in a cluster as 'spurious' *se*.

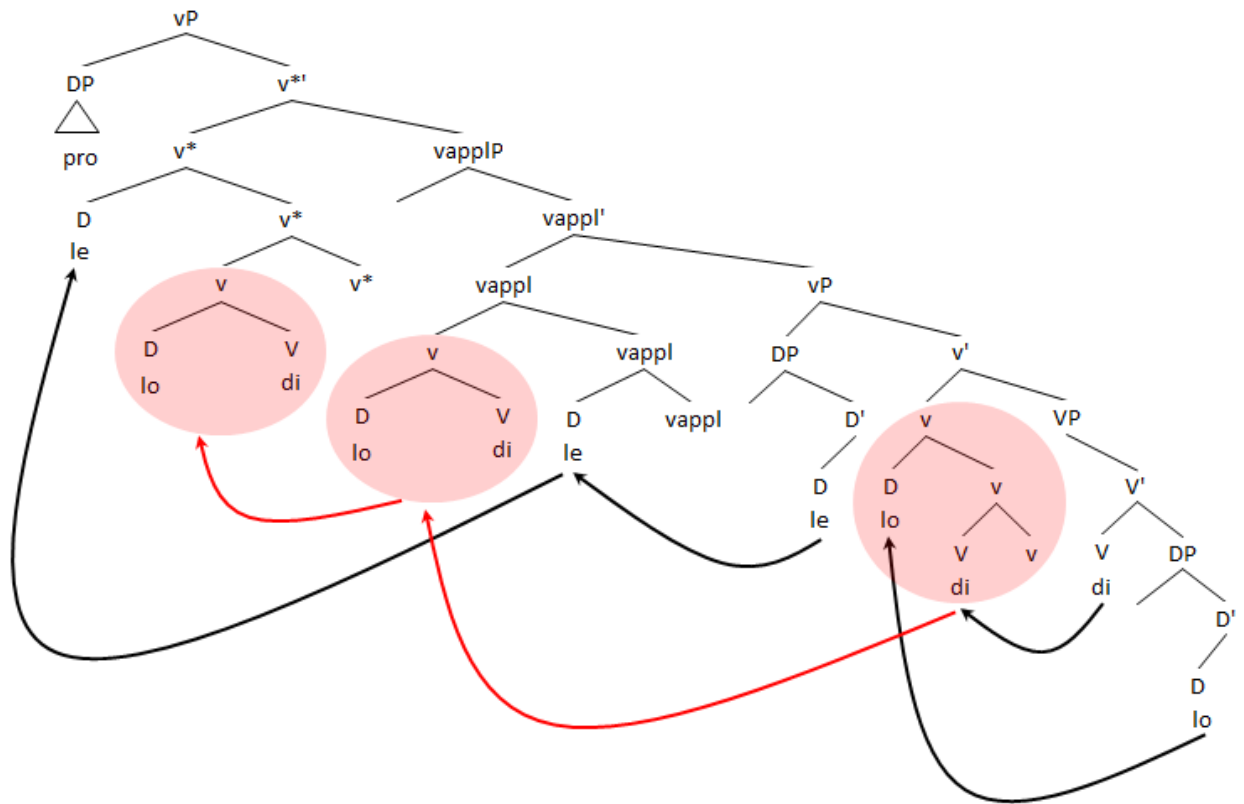

In Roberts's set-up in Figure 4.7, the verbal phase headed by v^* contains a phrase dedicated to introducing the dative argument (' $vapplP$ ') and a lower vP that introduces the Root V and its sister, the direct object clitic. Roberts first instantiates head movement of the DO clitic *lo* to the non-phase head v , where, via roll-up in the complex head containing $V-v$, it then undergoes head movement to $vappl$. $vappl$ also generates the dative clitic morpheme *le*. As the $v/V/DO$ complex head continues rolling-up, next landing in the phase head v^* , the dative clitic subsequently incorporates as a head into the left edge of v^* , adjoined to the complex head containing the DO clitic. The clitics then make their way to T (not shown in Figure 4.7), via $v-T$ movement.

Despite the success of Roberts's approach in deriving the correct order of clitics and verb in Fig. 4.7, we feel that the introduction of the applicative needlessly complicates matters. We maintain that the basic Larsonian shell, with the IO externally merged in $[Spec, VP]$ and the DO as the sister to V , is conceptually simpler and more elegant than the structure with the applicative,

although we understand that our configuration may not meet the desiderata of current assumptions regarding verbal argument structure (cf. Marantz 2013). Our model can be adapted easily enough though to meet the specifications of applicative approaches, if need be. However, we will leave this matter for future research.

4.12 Concluding Remarks

We conclude our final chapter of literature review by observing that all of the necessary assumptions are in place to present our original analysis. In this chapter we have reviewed the main pillars of Phase Theory and Relativized Minimality (RM). The latter is crucial for clitic movement, which can span intermediate heads. This is possible under current assumptions where minimality respects features, and not positions, as relevant interveners. As we will see in detail in the following chapter, the Phase Impenetrability Condition (PIC), along with RM, are sufficient to account for locality effects that both verbs and clitics obey when they move as minimal elements. This observation allows us to dispense with the Head Movement Constraint (HMC), which was problematic for movement accounts of clitics in the Government and Binding period, as clitics often appear to skip intervening head positions in their movement trajectory.

We have also reviewed the arguments for and against syntactic head movement, and concluded, along with Ian Roberts, that syntactic head movement does exist, and is the operation responsible for verb, auxiliary, and clitic movement in languages like Spanish. In our summary of his lengthy account of the topic, we found many points of convergence with Roberts in the relevant details of his head movement analysis of clitics in Romance. For example, we agree with his argument that clitics are minimal nominal elements that move from argument position to the phase head v^* , an operation triggered by agreement of matching phi features. We are further

indebted to Roberts's technical implementation of the head movement operation itself, in which the goal head is a featural subset of its agreeing probe, allowing head-to-head adjunction to project a label in the syntax, in line with bare phrase structure.

However, we depart from his account when he claims that clitics are structurally deficient, lacking a Case feature (following Cardinaletti and Starke 1999). As we have argued throughout this work, there are many empirical arguments for making clitics determiners. Our move to put Case on clitics nicely assimilates these elements into the grammar, and circumvents the postulation of special categories for clitics. With regard to this aspect of our analysis, we acknowledge the influence of Boeckx and Gallego (2008). In a brief but thorough discussion of clitics in Phase Theory, they make a convincing argument for putting Case on clitics. As we have previously mentioned, the intuition that Spanish clitics are determiners has existed since the time of Bello (1847), and has been recently revived by Torrego (1987) and Uriagereka (1988). We have shown that there are good reasons to retain this intuition. The main motivation in Roberts's framework for making clitics ϕ Ps is so that they will serve as 'defective goals,' i.e., goals that contain a featural subset of the agreeing probe, which will enable the mechanism that triggers and facilitates head movement. We demonstrated that this problem can be circumvented by putting matching uninterpretable Case features on the probes that assign Case. In our account, structural Case assignment follows through a complete match of features on the probe and goal.

These points of divergence from Roberts's account, though few in number, have major implications, as we will see in Chapter 4, when we seek Phase Theoretic explanations for clitic movement in clusters and ECM constructions in particular. The presence and absence of Case features on clitics will play a crucial role in the array of structures to be considered. However, we will ultimately find Roberts's idea of 'defective goals' to be crucial in distinguishing instances in

which clitics move as heads (and hence are ‘defective’) and when they move as maximal elements, XPs. Thus, the mechanism that triggers head movement in our account is essentially the one posited by Roberts, while our introduction of Case onto the clitic allows us to expand the number and complexity of clitic constructions to be accounted for in Spanish, and furthermore, yields an explanation of a myriad of intervention effects involving clitics and their doubles that have not been discussed in great detail in the current framework.

CHAPTER 5

Clitics by Phase: Move D Heads!

5.1 Role of Case: Prefacing the Analysis

In this chapter we will present our analysis of the derivation of pronominal clitics in Spanish. After we derive the basic clitic constructions, we move onto more complicated examples involving auxiliaries, passives, and clitic climbing. We then turn to further empirical arguments in support of our move to put Case features on object clitics, as we observe that the placement of clitics in complex ECM configurations (with two clitics raising to object) must be tied to Case assignment. We will also observe how head movement figures crucially into this account, where multiple minimal arguments are able to enter into a configuration that is not permitted to the XP doubles of these elements. To be precise, two clitic arguments may raise to object in Spanish ECM constructions, while only one DP may raise to object under the same conditions. This is predicted by our analysis in which clitics are terminal elements whose movement relates to the valuation of Case on a higher finite verb. In complex ECM constructions, the embedded direct object clitic raises and gets valued with accusative Case on the higher verb, and the embedded subject clitic raises and is valued with the remaining structural Case available to it, dative Case. When the element that moves is an XP, it may only pick up one object Case,

but cannot move with another argument, whose would-be transit to the main clause is blocked. The observed intervention effects are explained by Relativized Minimality—interveners still carrying Case features block other Case-bearing elements seeking to value and delete their uninterpretable Case features. This will explain why a clitic and a full DP cannot both raise to object—the predicate-internal subject of the higher phase in [Spec, v*P] acts as a barrier to movement of the embedded maximal expression (XP).

While we will observe in detail how Relativized Minimality (RM) is the principle at work with intervention effects involving clitics, we will also discover that the Phase Impenetrability Condition (PIC) explains other island effects induced by clitic movement, including *wh*-islands and those involving clausal negation. These two principles of locality work in tandem to filter out the kinds of illicit derivations with clitics observed by Kayne (1975) and Quicoli (1976). We use the PIC and RM to provide an explanation of abstract conditions on clitic movement that extends upon the original observations made in that work to a larger domain of possibilities with clitics in Spanish, where two-clitic and even three-clitic clusters are easily controlled by most native speakers in a variety of constructions suggestive of movement.

In the next section, we will introduce the technical specifications suggested by our approach, including step-by-step derivations of all the relevant constructions. With these desiderata in place, we can conclude by addressing unresolved questions:

- (1)
 - a. Why do basic clitic clusters NOT violate Relativized Minimality?
 - b. Why must clitics move as maximal AND minimal elements?
 - c. Why can embedded IO clitics not raise to object in ECM constructions?
 - d. How can we distinguish between the movement of doubles and clitics?

e. What role does the PIC play in filtering out bad clitic constructions?

5.2 Basic Clitic Constructions

We are now ready to spell out the details of our own proposal, building on the classic accounts of clitic movement and the leading ideas at the frontiers of Phase Theory. As we have argued in the previous chapters, argument clitics are syntactically licensed as nominal elements (Ds) that enter the derivation looking to value and delete their Case features. Once they agree with a probe that can satisfy this condition, they should be rendered inert and unable to participate in further syntactic operations. The basic setup, before movement, for a simple clitic construction, such as the sentence in (2), is sketched in Figure 5.1:

- (2) Yo la veo.
 I her._{ACC.FEM} see
 “I see her.”

Figure 5.1: Direct Object Clitic in Base Configuration

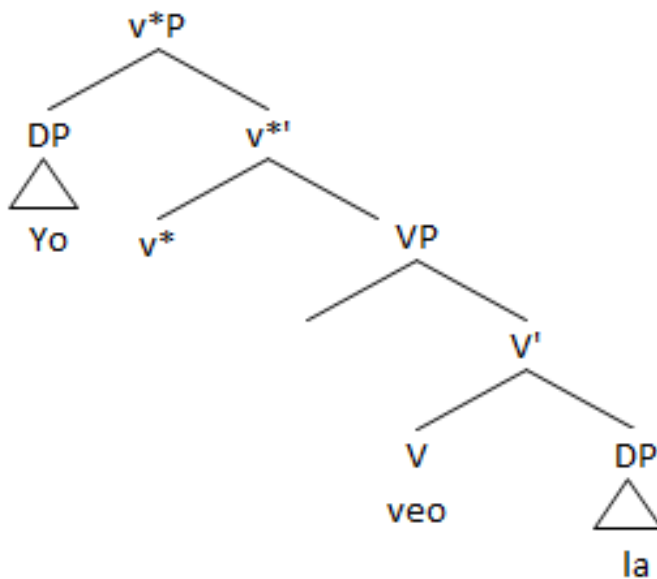

As we can see in Figure 5.1, the accusative clitic is generated as the DP internal argument of the root verb V, *veo*, and the subject *Yo* ('I') is generated in the predicate-internal subject position, [Spec, v*P]. In figure 5.2, we add the feature distributions to this basic setup, and expand the view of the derivation to include the inflectional region (i.e., T and TP), for sentence (2):

Figure 5.2: Feature Distribution for Single Clitic Agreement

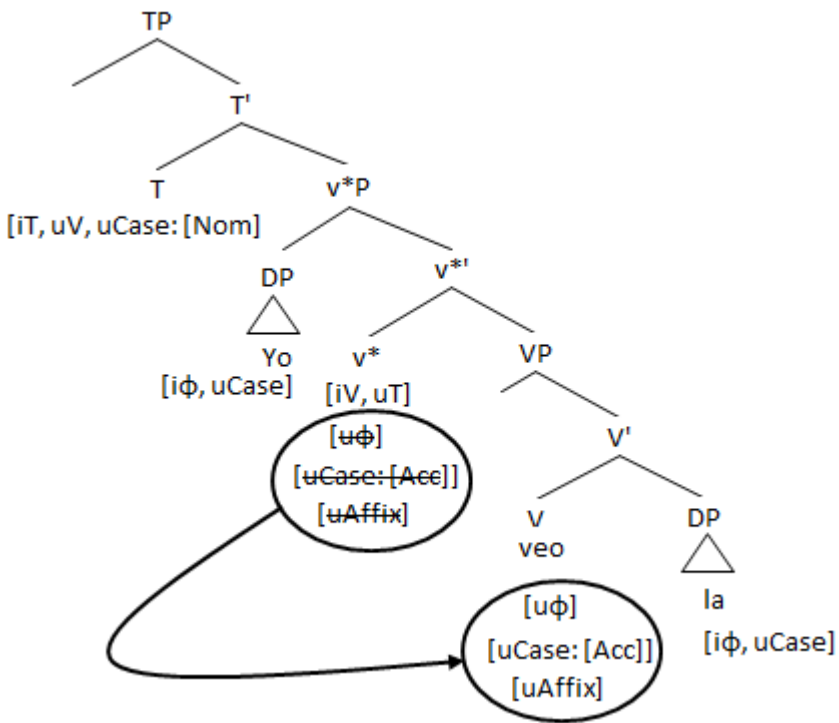

As we can see in Figure 4.2, after the v* phase is built up, v* must then hand down its phi-, Case, and affix features to the lexical item it selects, V, via the operation of Inheritance. Note that the uninterpretable Case feature coming from v* is valued, +Acc. All that v* is left with after Inheritance is an uninterpretable T feature and an interpretable V feature related to full argument structure—this last feature has an uninterpretable match on T (Roberts 2010: 161). Upon Inheritance of relevant features from v*, the V probe searches its immediate local domain and finds the active DP clitic goal *la*, which is active by virtue of carrying an uninterpretable Case

feature. As a result of being probed, the clitic enters into an Agree relation with V, valuing the uninterpretable phi-features of V. Upon a match of Case features, the clitic is assigned structural accusative Case. As V also inherits v^* 's affix feature, agreement between V and the naturally affixal clitic triggers head movement of *la* to the edge of V, via head-to-head incorporation. Following Roberts, we posit that cliticization via incorporation is possible because the clitic's features represent a proper subset of the features on the probe. This is the essence of Roberts's notion of a 'defective goal', restated in (3):

- (2) A goal G is defective iff G's formal features are a proper subset of those of G's Probe P.

(Roberts 2010a: 62)

Although the clitic has lost its uninterpretable features at this point in the derivation, and is hence 'frozen' in place, it can move via 'roll up' when V then undergoes head movement to v^* . According to Roberts, the v^* probe is still active by virtue of carrying an uninterpretable T feature. Finding no suitable goals below it, v^* must wait until the next phase is built, where it can resume its search for a goal that can delete its uT feature. When v^* does eventually find a matching goal in T, where tense is naturally interpretable, it undergoes v-T movement, carrying the accusative clitic along with it, where it surfaces in sentence (2). The sequence of movements involved in the derivation of sentence (2) is depicted in Figure 5.3:

Figure 5.3: Derivation of *Yo la veo* ('I see her')

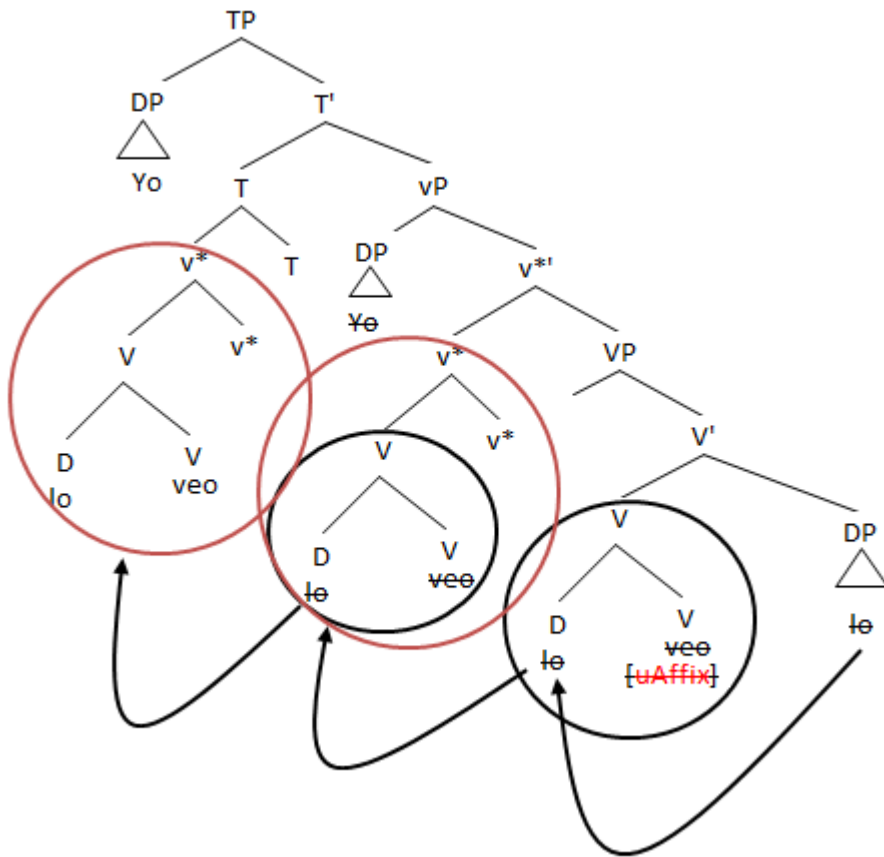

In Figure 5.3, we can clearly see that the clitic *la* first moves as a head into the edge of V. Then V to v head movement carries the clitic and the root V to the edge of v*. Finally, v to T head movement transports the contents of v* to T.

5.3 Dative Clitic Constructions

Now let us turn our attention to sentences with dative clitics. Start with a sentence an indirect object clitic and full DP direct object, such as the construction in (4):

- (3) Juan le dio el libro.
 Juan her._{DAT} gave the book
 “Juan gave her the book.”

Recall from the discussion of dative constructions in Chapter 1 that constructions with a dative clitic in Spanish are double object constructions. Also recall that in the basic Larsonian-shell approach to these sentences, we generate the direct object as the sister to V, as usual, and the indirect object in [Spec, VP]. Observe the base configuration of (4) in Figure 5.4:

Figure 5.4: Basic Setup of a Double Object Construction (IO clitic + DO DP)

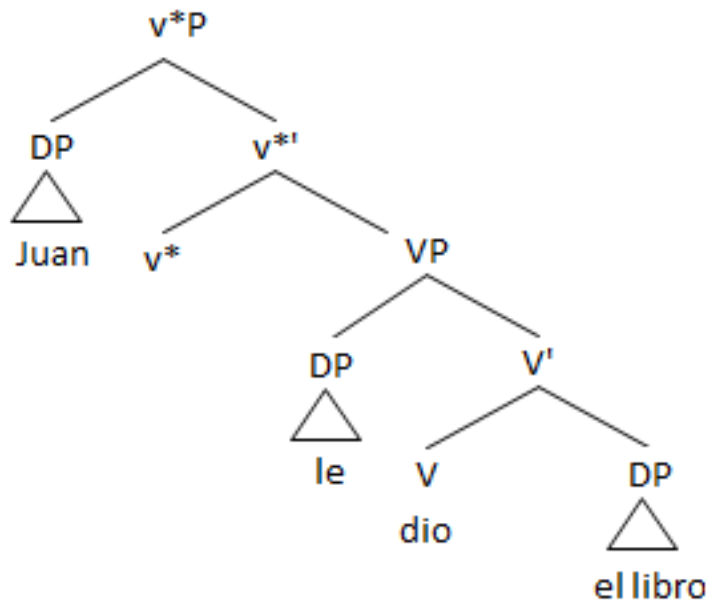

The feature distribution for this sentence is in Figure 5.5:

Figure 5.5: Feature Distribution for a Double Object Construction

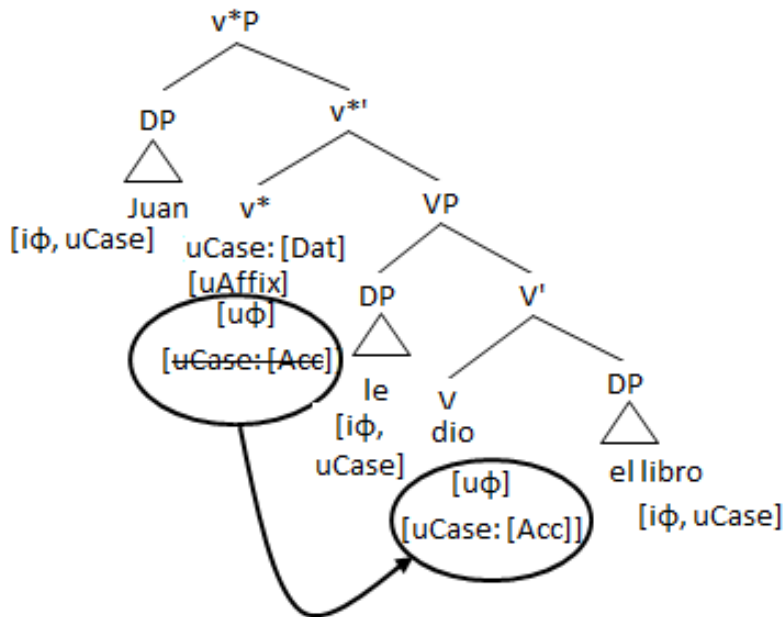

In Figure 5.5 above, the DO *el libro* merges with the root V, *dio*. The resulting projection then merges with the IO clitic *le*. The phase head v^* then merges with the VP, and the subject *Juan* merges with the phase head. Upon the construction of the entire phase, v^* passes down phi-features and the Accusative Case feature. Notice that in this derivation, v^* keeps a set of phi-features for itself, and it does not pass down the Affix feature to V. Furthermore on v^* , there is an uninterpretable Case feature valued +Dat. Phase-level operations then commence, with V the first head to probe. V agrees with the DP *el libro* in the relevant features, assigns it accusative Case, and uninterpretable features get deleted. Without an affix or EPP feature on V, *el libro* can stay in its theta-position, *in situ*. The next head to probe is v^* . v^* searches in its immediate domain and finds the dative clitic *le*. Due to the presence of the uninterpretable Affix feature on the phase head, agreement of v^* with the IO results in movement of the dative clitic. The clitic moves as a head to the edge of v^* . Upon the construction of the next phase, v to T movement proceeds as usual (once again thanks to the uT feature on v^* and the uV feature on T), and the

dativ e clitic finally makes its way to T, via movement of the light verb to T. The series of movements involved in the derivation of sentence (4) is sketched in Figure 5.6:

Figure 5.6: Derivation of *Juan le dio el libro* ('Juan gave her the book')

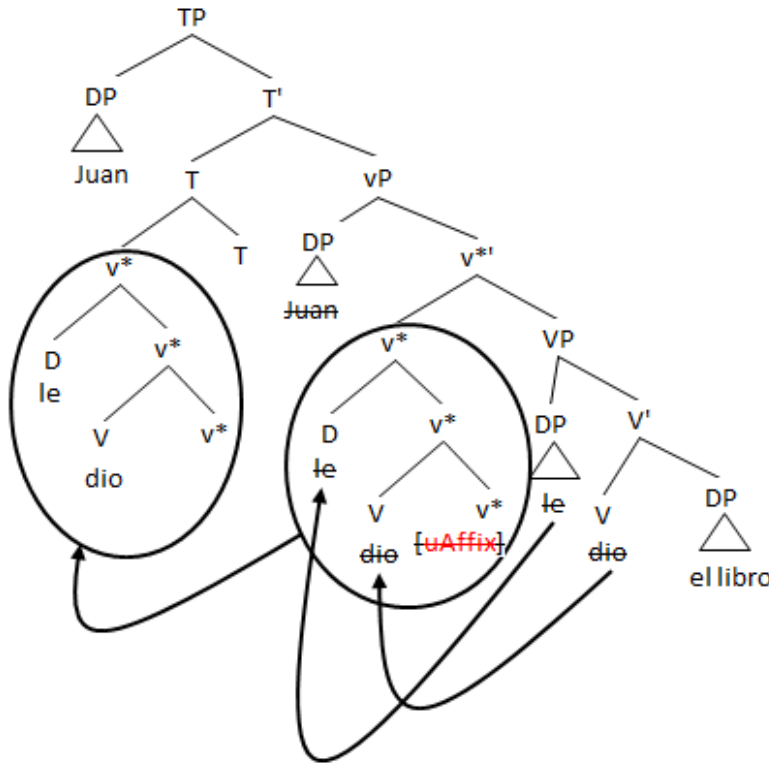

We are now ready to derive a simple clitic cluster, with both DO and IO clitics, such as in (7):

- (7) Juan me lo dio.
 Juan me.DAT it.ACC.MASC gave
 "Juan gave me it."

The feature setup for the construction in (7) is in Figure 5.7:

Figure 5.7: Feature Distribution for a Clitic Cluster

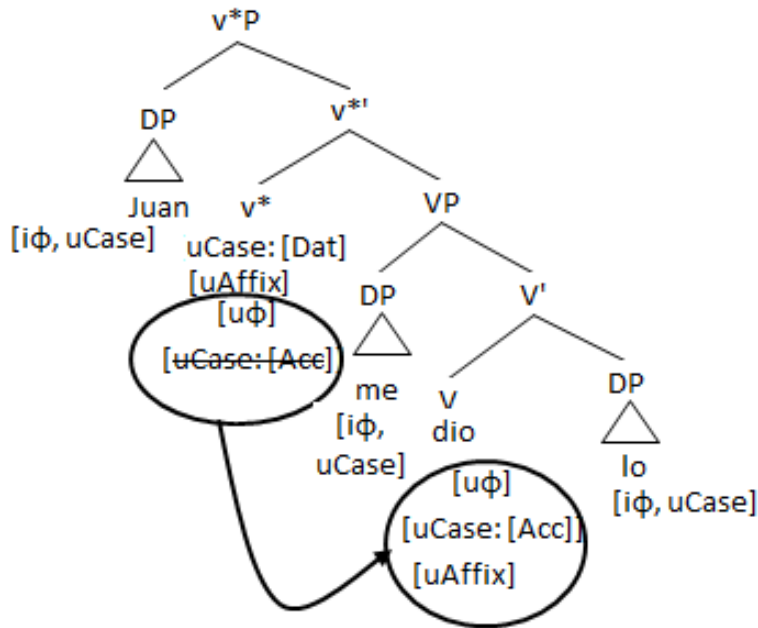

The clitic cluster setup in Figure 5.7 is identical to the setup of the double object construction in Figure 5.5, except that in Fig. 5.7 the DO DP is replaced with a clitic (*lo*), and, more importantly, the phase head v^* passes down a copy of its Affix feature to V. This will be crucial in attracting the clitic. However, the observant reader will surely note that the structure depicted in Fig. 5.7 poses a potential problem for the approach outlined here. If we assume that the DO clitic starts as the sister to V and the IO clitic in [Spec, VP], then to obtain the correct surface order of the sentence in (7) (i.e., IO-DO-V), then the DO and IO should cross over each other when they move to the edge of the verb. Minimality should forbid this set of movements, since we assume that the IO and DO are both determiners carrying Case features. Hence, we are already undone in one of the most basic configurations to be outlined!

Not exactly—our posited order of movements is actually fine, under the new theoretic assumptions provided by Phase Theory. The key technical innovation of the theory that allows this order of movements to proceed is Chomsky’s Inheritance operation. Recall that feature

Inheritance gives V the features with which it probes and agrees with the DO clitic. If v^* did not pass down its features, then the v^* probe would not initially find the DO because of the intervening IO, which would get valued/moved first, and then the DO would move second, yielding the wrong surface order to yield a bad string such as:

- (8) *Juan lo me dio.
Juan it._{ACC·MASC} me._{DAT} gave
*“Juan gave it me.”

But given the operation of Inheritance, there is no longer an intervening element between the V probe and the DO. In our model, the DO gets its Case feature deleted at the same time it moves into the edge of V to delete V's $u\text{Affix}$. The c-commanding IO in [Spec, VP] fails to act as an intervener, since the DO clitic free rides on V to the light verb. Since V at this point is just a Root looking to incorporate into the light verb, verb movement proceeds naturally and the clitic on V passes by the IO undetected. Alternatively, it may be that the IO clitic does not act as an intervener for the DO clitic because the IO is only specified for number and person features, but not gender. As such, the IO would not be as fully specified in terms of interpretable phi-features as the DO. Under either scenario, locality is respected and the derivation continues.

After the CL/V complex moves into v^* , v^* is still an active probe. Not only does it carry an uninterpretable T feature (which it needs to move to T), but in the case of double object constructions, it must also carry a copy of the same phi features that it handed down to V. Recall from the discussion of Phase Theory in Chapter 4 that there is evidence that phase heads can keep a copy of their phi-features, even after Inheritance. This comes from complementizer-subject agreement, found in languages such as West Flemish (Haegeman 1992: 47). We argued

that Haegeman’s facts can be interpreted to suggest that feature Inheritance is sometimes a copying operation, in which C’s agreement features are copied onto T. We suggested that feature Inheritance on the v^* phase head should work in a similar fashion, to develop even further Chomsky’s symmetric analysis of the two phase heads (i.e, v^* and C). If Inheritance may involve copying, then the ‘double agreement’ observed in double object constructions is explained. Therefore, we conjecture that even after V-v movement, v^* is still an active probe carrying a complete set of ϕ -features and an Affix feature, as shown in Fig. 5.7. These steps can be visualized in the derivational sketch of the sentence in example (7), in Figure 5.8:

Figure 5.8: Derivation of *Juan me lo dio* (‘Juan gave me it’)

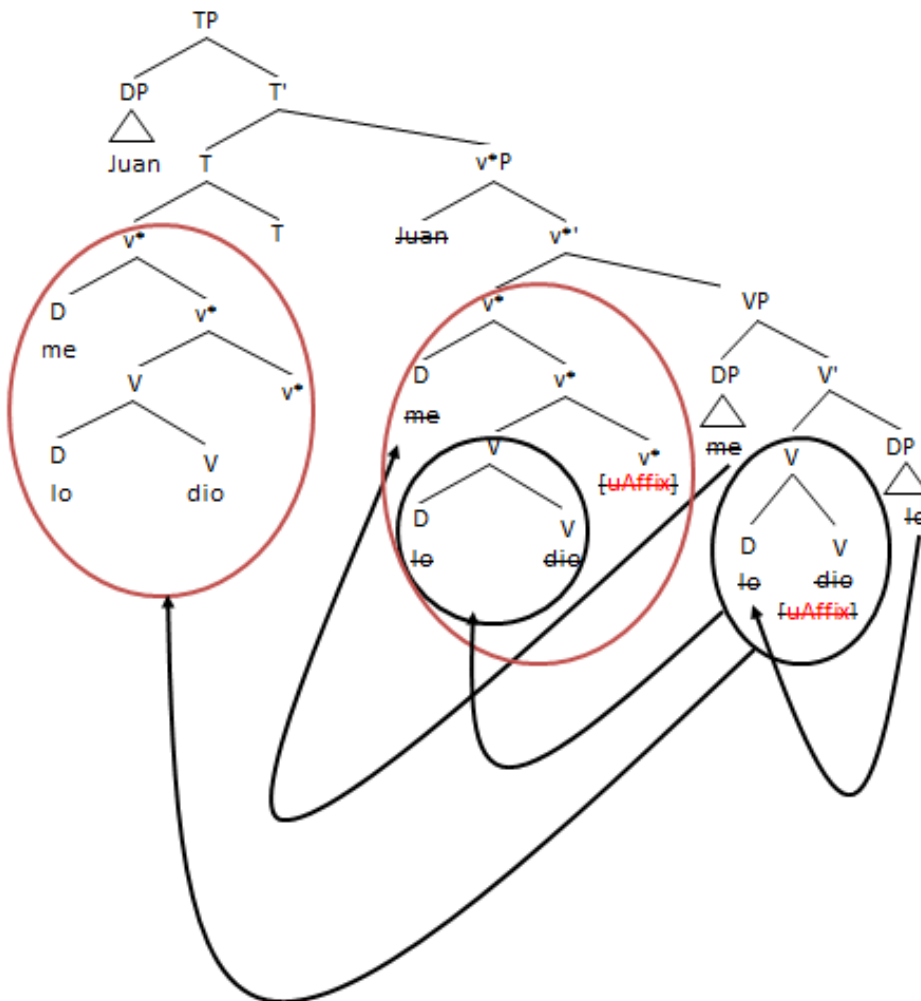

As we can see in Figure 5.8, the first set of movements involve head movement of the DO clitic into the edge of V (triggered by the uAffix feature on V), and then movement of the complex head in V to the edge of v*, as in V-v* movement. When v* then probes into its immediate search domain, it finds the dative clitic. The Case feature of v* values the uninterpretable Case feature of the dative clitic, and upon Agree, the dative clitic moves as a head into v*. This movement is forced by the presence of the affix feature on v*. Agreement with the clitic values and deletes that feature from the light verb. The dative clitic incorporates into the periphery of the complex head already in v*, to the left of the accusative clitic. The observant reader might well ask again--why does THIS not violate Minimality? Since the IO clitic moves by itself into the edge of the DO, without a verb to ride on, should it not be blocked from adjoining to the DO? If head movement is to be completely assimilated to XP movement, as this analysis intends, then the element in the left edge of the head to be adjoined to should count as an intervener. Once again we are faced with a challenge in the form of Minimality.

Recall, though, that Relativized Minimality requires that the intervening element be FULLY specified in terms of features to induce a violation. At the point the IO must adjoin to the complex head in v*, however, the DO no longer has a Case feature. That feature was deleted upon Agreement with V. This leaves the IO clitic with one extra feature with which to move around the DO. And dative Case valuation only renders the IO inactive for further operations once it has already moved, since movement and Case deletion occur simultaneously. And thus a serious conceptual problem that has left many researchers hesitant to postulate movement of both IO and DO clitics is circumvented. This also gives us an answer to the question proposed in (1a), namely why the order of movements in clitic clusters does not violate Relativized Minimality.

5.4 Phrasal Movement of Clitics

Now consider a clitic construction with an auxiliary and a past participle, such in (9):

- (9) Yo lo he visto. (Spanish)
I them._{ACC·MASC} have seen
“I have seen it.”

One problem that the analysis of such a construction raises is the fact that in other Romance languages, such as French and Italian, the participle shows overt gender and number agreement with the accusative clitic:

- (10) L’ho vista/*o (Italian)
her._{ACC·FEM} I have seen._{PPRT·FEM}
“I have seen her”

- (11) Gli ho visti/*o (Italian)
them_{ACC·PLUR} I have seen._{PPRT·PLUR}
“I have seen them”

Although equivalent expressions in Spanish do not show overt agreement on the past participle, passive participles involving clitics in Spanish do, as in (12):

- (12) Yo las vi ser atacadas.¹
I them._{ACC·PLUR·FEM} saw be._{INF} attacked._{PPRT·PLUR·FEM}
“I saw them get attacked”

¹ I am indebted to Carlos Quicoli (p.c.) for bringing this construction to my attention.

These facts suggest that the clitic enters into an Agree relation with the participle at some point in the derivation. Recall that in Phase Theory, (Chomsky 2001: 18), participial-object agreement is adjectival in nature. As such, it is characterized by agreement in number and gender features, but not in person. Thus, as we observed in Chapter 3, Prt-Obj agreement does not render the object goal inactive, in accordance with Chomsky’s Completeness Condition. As we will see, this condition will be crucially relevant to our account of clitics as well.

First, let us see how the Completeness Condition applies with a simple periphrastic sentence involving an auxiliary and a past participle, as in example (9), sketched in Figure 5.9:

Figure 5.9: Derivation of *Lo he visto* (‘I have seen it’)

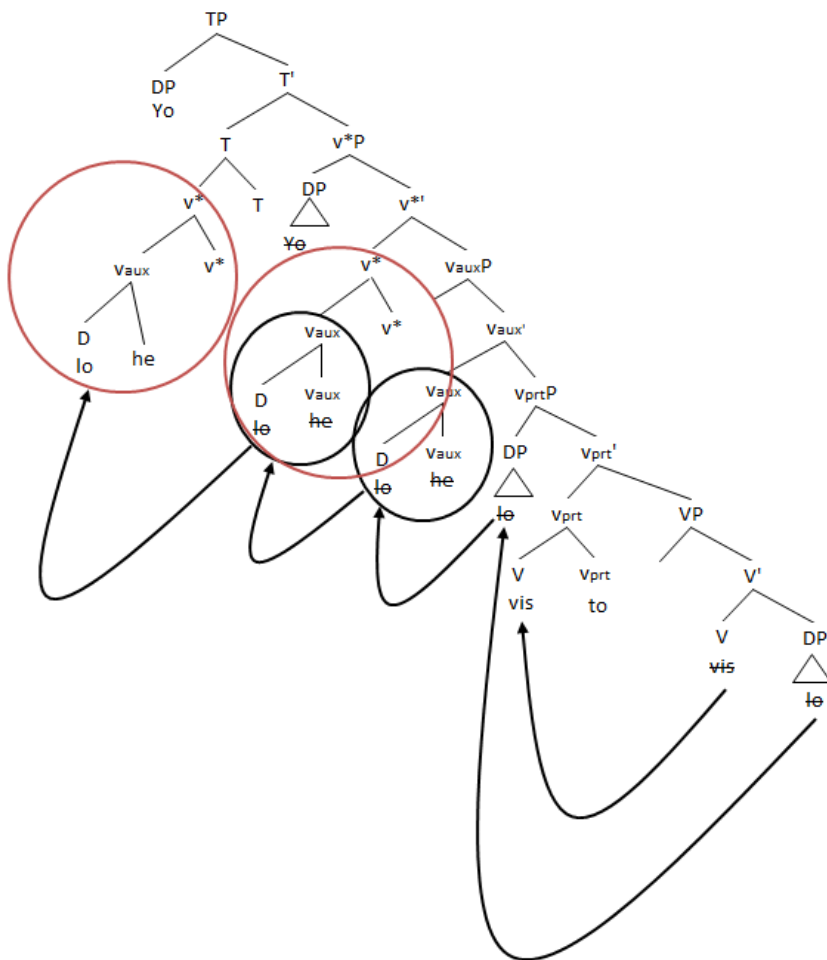

In Figure 5.9, the verbal phase is headed by v^* , since this is a transitive sentence with full argument structure. But assume that in periphrastic sentences v^* does not select the Root VP, but instead selects the auxiliary, ‘vauxP’. Why not make *vaux* the phase head? We assume that auxiliaries do not project external arguments, that only main verbs do so (Solà 2002). As such, we maintain that the light verb v^* retain phase head status. Next, we retain Chomsky’s generalization that the LI that v^* selects inherits a copy of its features. In this derivation, *vaux* then becomes the beneficiary of Inheritance. The consequences of this will be explained in a moment. *vaux* then selects *vp_{prt}*, the participle head, which in turn selects the Root VP.

After the Root combines with the participle (which we take to be an inherent property of roots), the head of *vp_{prt}* probes and finds the clitic *lo*, with which it agrees. Since *vp_{prt}* only has number and gender features, it cannot value the Case feature of the clitic. Thus, the clitic remains active after Agree. Unlike the cliticization operation, which is head movement to a ϕ -complete probe, assume that agreement of the clitic with the participle results in phrasal movement of the clitic to [Spec, *vp_{prt}*]. This follows straightforwardly from Roberts’s contention that only ‘defective goals’ are candidates for head-to-head incorporation. In this case, the goal clitic is not defective, since it has more features than the participle probe (i.e., Case and person features). Therefore, head movement cannot proceed, and the clitic must move as a maximal element, DP.²

Returning to the derivation, once the clitic moves into the specifier of the participle, the next active probe in the derivation should be *vaux*. It is ϕ -complete, courtesy of Inheritance from v^* . It finds the clitic in its immediate domain and agrees with it. As the clitic’s features are a proper subset of *vaux*, the clitic incorporates into *vaux*, get its accusative Case valued, and

² Actually, it has been well known that clitics move as both maximal and minimal elements since Sportiche (1996).

becomes inactive.³ In this construction, standard V to v movement is instantiated by movement of *vaux* to *v** (since the auxiliary is the tensed verb that must make it all the way to T). With CL/*vaux* in *v**, the derivation proceeds like a basic clitic construction, with an inert clitic riding to T via sequential verb movements.

From this point, clitic clusters in compound tenses with past participles are derived easily. Consider the following sentence with an auxiliary and IO-DO clitic sequence in example (13), with accompanying derivational diagram in Figure 5.10:

- (13) Juan me lo ha dicho.
Juan me._{DAT} it._{ACC-MASC} has told
“Juan has told me it.”

Figure 5.10: Derivation of *Juan me lo ha dicho* (‘Juan has told me it’)

³ Because our account predicts that object Case features can be picked up by *v** in the Numeration and handed down to whatever lexical item *v** selects, we posit that although uninterpretable, the Case features associated with *v** (dative) and V (accusative) enter the derivation valued, as +ACC or +DAT. Upon Agree, then, the +ACC feature on V (or *vaux*) values the uninterpretable, unvalued Case feature on the nominal, and in the process, both Case features on goal and probe get deleted.



As depicted in Fig. 5.10, when *vprt* begins to probe, the first goal in its immediate domain is the dative clitic *le*. Recall that *vprt* has number and gender, while the dative clitic only marks for number and person—with no gender. Thus, upon agree, neither *vprt* nor the dative clitic is inactivated—they mismatch in the feature they lack. The result is that *le* moves to the spec of *vprt* while *vprt* remains an active probe. It must then continue its search procedure and finds the accusative clitic, which has gender and thus can delete the final unvalued feature on the participle probe. The DO clitic moves to the edge of *vprt*, in a higher specifier of that category. It can be merged into the specifier above the landing site of the dative clitic because, again, we posit the dative clitic to lack a gender feature—as such, the DO at this point has one more

relevant feature than the IO and avoids Minimality when moving into higher specifier. Now we have a familiar configuration, analogous to simple clitic clusters. *vaux* agrees and attracts the DO to its head. Movement of the CL/*vaux* complex goes to v^* , which keeps a copy of its features with which it uses to attract the dative clitic. Now, both clitics and the auxiliary find themselves in the right order, and inside v^* , for a free ride to the inflectional region.

The one movement that we have not accounted for in our proposal is the movement of the dative clitic by itself, over the DO, to cliticize into *vaux*, in Figure 5.10 above. This movement passes two copies of the DO on the way to the edge of *vaux*. We earlier posited that upon full Agree, the clitic's Case feature is deleted—thus allowing for dative cliticization to avoid a minimality violation. In the derivation in Figure 5.10, though, the dative clitic must also move over the lower copy of the DO, which presumably still has Case—this would violate RM. As such, we assume that both copies of the DO—before and after cliticization—lack Case, since Case valuation/deletion is an instantaneous process, and should apply equally to both copies. Deletion of Case features, which is required before the structures are sent to LF, allows IO cliticization to proceed readily.

Finally, consider the derivation of clitic constructions with agreeing passive participles in Spanish, such as in the ECM sentence in (12) (*Yo las vi ser atacadas*). The lower clause headed by the passive participle *atacadas* ('attacked') is a 'defective phase'. Recall from our discussion of Phase Theory in Chapter 4 that the passive vP (like *vp_{prt}* in transitive periphrastic compounds) is not totally defective, but only partially so, containing gender and number features, but no person feature (cf. Richards 2012: 214). In our derivation of example (12), shown in Fig. 5.11, the phase head that introduces the participle is also *vp_{prt}*:

Figure 5.11: Derivation of *Yo las vi ser atacadas* ('I saw them get attacked')

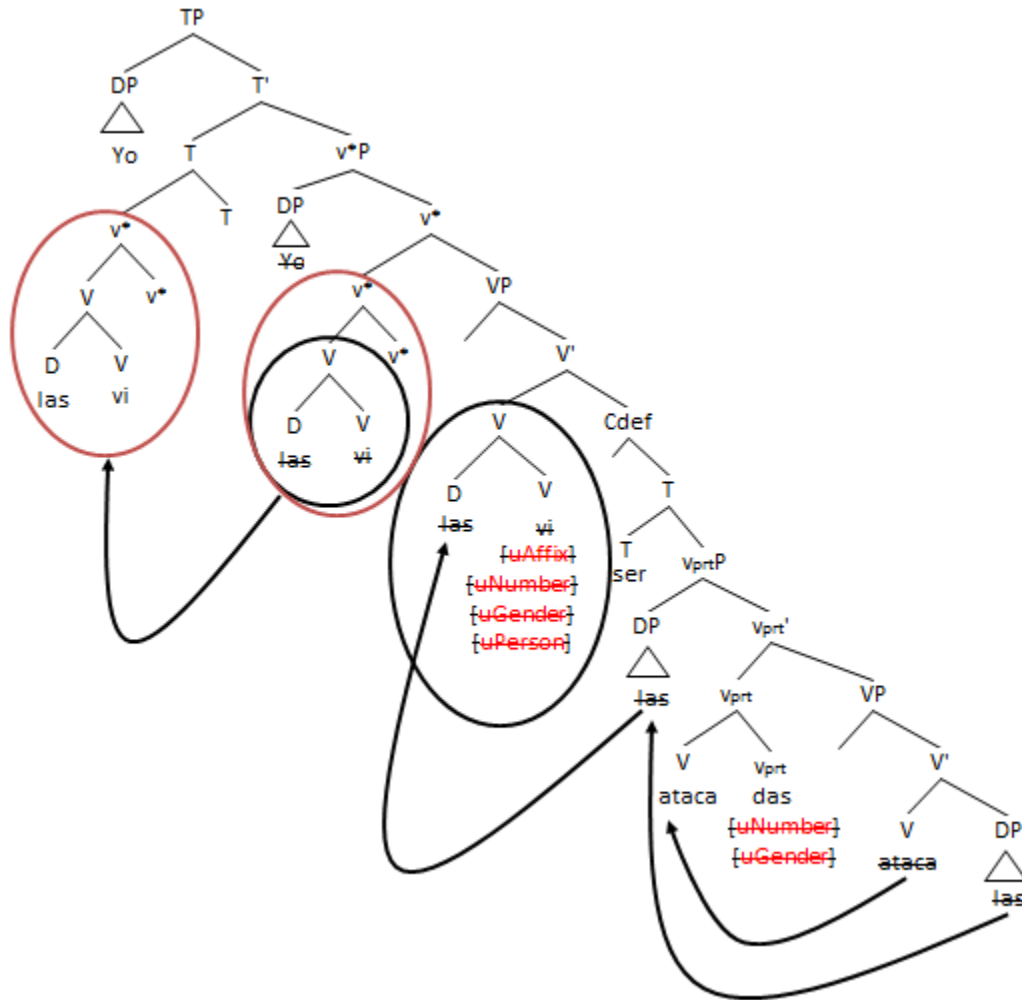

In Fig. 5.11, *vprt* selects root *V*. Since it is a defective phase head, *vprt* does not transmit its features to *V*. As a result, *V* has no ϕ -features to value with which to probe. It does, however, contain a feature that allows it to combine with the participle in *vprt*. After head movement of *V* into the participle, the next probe up is the phase head *vprt*. It finds the clitic *las*, with which it agrees. Since *vprt* only has number and gender features, it cannot value and delete the Case feature of the clitic. Thus, the clitic remains active after Agree. Once again, assume that agreement of the clitic with the participle results in phrasal movement of the clitic to spec of *vprt*. This position acts as an escape hatch. The next structure to be merged is the completely defective

Cdef (and specifierless T). Cdef lacks an active probe, since it contains no features. The only lexical item in Cdef's area is the nonfinite auxiliary, *ser*, base-generated in T. The next active probe is thus V of the matrix clause, which has inherited the features of v^* . Since Cdef is transparent, V can look through it and see *las* on the edge of $vprt$. V's feature set is complete and it can attract the clitic into its head. Now the clitic is finally rendered inert, having been assigned structural Case. It moves from V to v^* to T of the finite clause, via roll up.

5.5 Clitic Climbing

With the above assumptions in place, we can account for clitic climbing (CC), whereby the clitic moves from an embedded infinitive to a finite matrix verb, as in the example in (14):

- (14) Ella lo quiere hacer.
she it._{ACC-MASC} wants do._{INF}
“She wants to do it.”

As we postulated for the derivation of the passive/ECM example (12) in Fig. 5.11, we assume the embedded clause in (14) is selected by the fully defective and featureless category Cdef. Like participles, we assume that infinitives in Spanish are defective in that they lack a grammatical feature. Instead of the person feature, which participles lack, we assume that Spanish infinitives lack Case features, and the climbing of the clitic to the matrix clause is triggered by the need to value and delete the Case feature on the finite verb. This is represented in Figure 5.12, where we set up the derivation for the climbing of single clitic with features:

Figure 5.12: Feature Distribution for Clitic Climbing

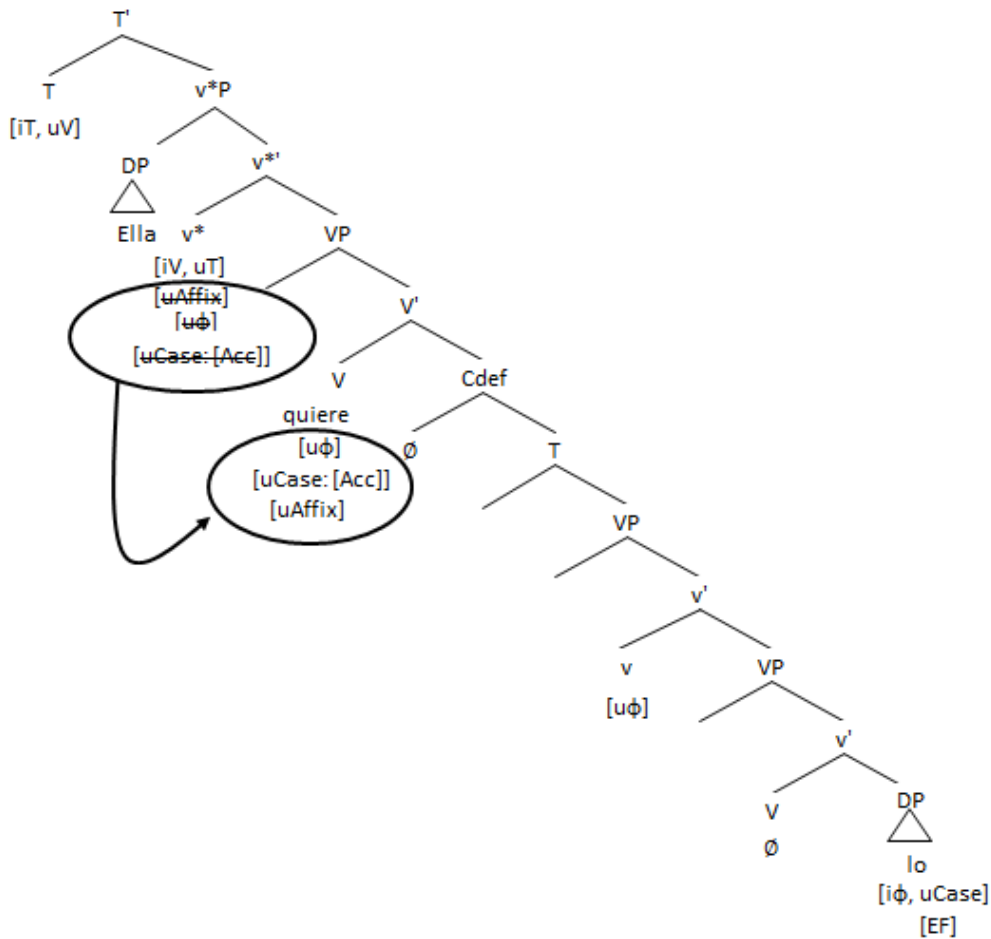

In Fig. 5.12, the lack of a Case feature on the embedded infinitive thus becomes the trigger for clitic climbing. Without a Case feature, the clitic in *v*'s domain receive Case, nor cliticize, given Roberts's notion of 'defective goals'. With that in mind, we consider how to approach a sentence like (14). As shown in Fig. 5.12, the lower phase head *v* associated with the infinitive *hacer* ('make, do') does not hand over its ϕ -features to *V* via feature Inheritance, since without Case it is defective, just as we saw with the passive phase head derivation in Fig. 5.11.⁴ As such, *v* probes first, and finds the closest goal in *lo*, sister to *V*. *v*'s two ϕ -features get valued and deleted in the process, but the Case feature of the clitic remains unvalued. Upon 'partially'

⁴ We will use the notation *v* for the embedded infinitive of clitic climbing predicates to distinguish it from featurally complete *v**. This is the head of a partially defective, weak phase. As it still introduces arguments, we assume that this is not a totally defective structure like *C_{def}*. As such, we assume *v* obeys the PIC, and that its complement undergoes Transfer.

agreeing with *v*, assume that the clitic DP moves to the left edge of the partially defective phase.

This is visualized in the derivational sketch of (14) in Figure 5.13:

Figure 5.13: Derivation of *Ella lo quiere hacer* ('She wants to do it')

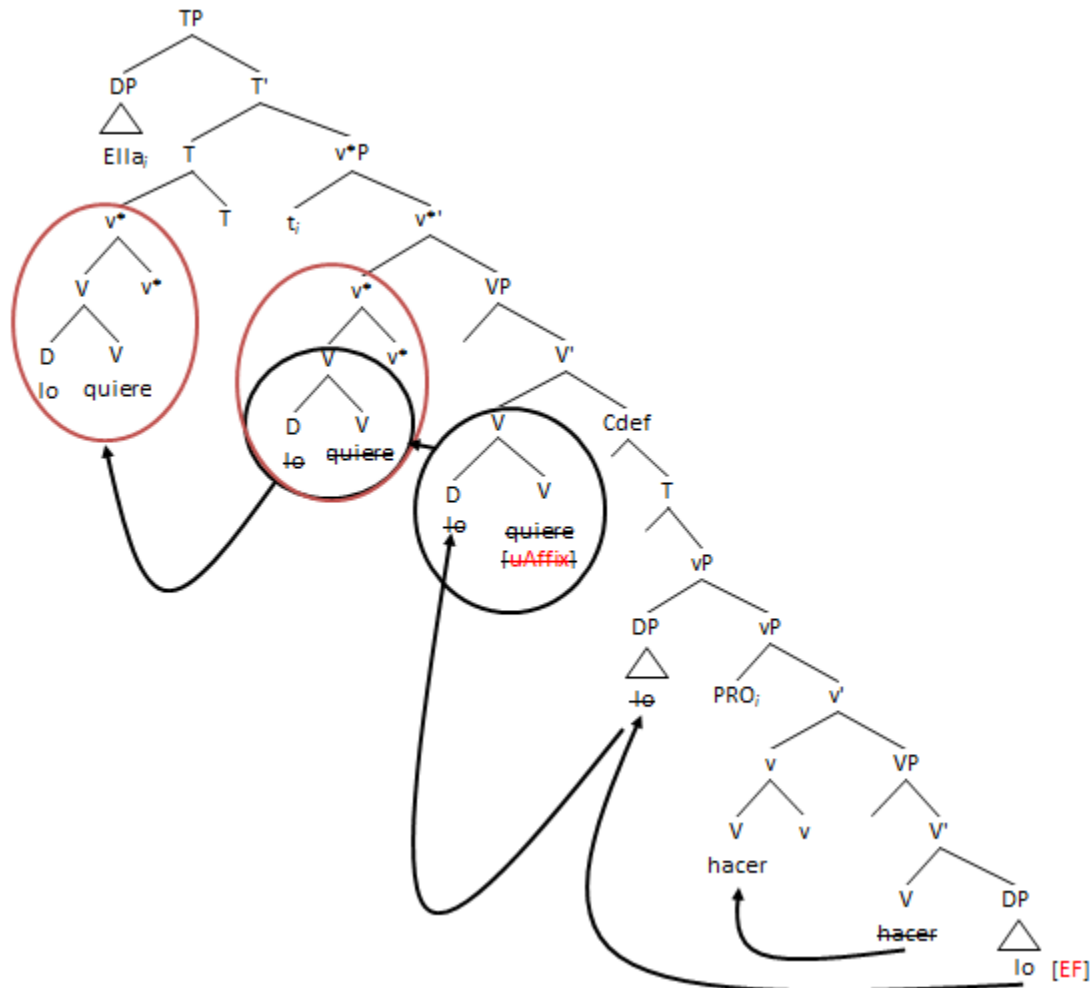

Via the Edge of spec vP, the clitic becomes visible to the higher, finite, *v** probe. Upon Agreement, the clitic incorporates into the left edge of V. V to *v** movement then puts the clitic and *quiere* in *v**. Upon the formation of the higher C phase, which hands down its ϕ -features to T, v-T movement commences, as does movement of the subject *Ella* into the specifier of TP, where it receives nominative Case.

Clitic climbing sentences with two clitics, such as in example (15) readily follow from the derivational steps outlined in Fig. 5.13:

- (15) Ella me las desea dar.
 she me.DAT them.ACC-FEM give-INF
 “She wants to give me them.”

In the derivation of (15) both the IO and DO clitic must move to the Edge of the lower infinitive, to escape the PIC, as in Figure 5.14:

Figure 5.14: Derivation of *Ella me las desea dar* (‘She wants to give me them’)

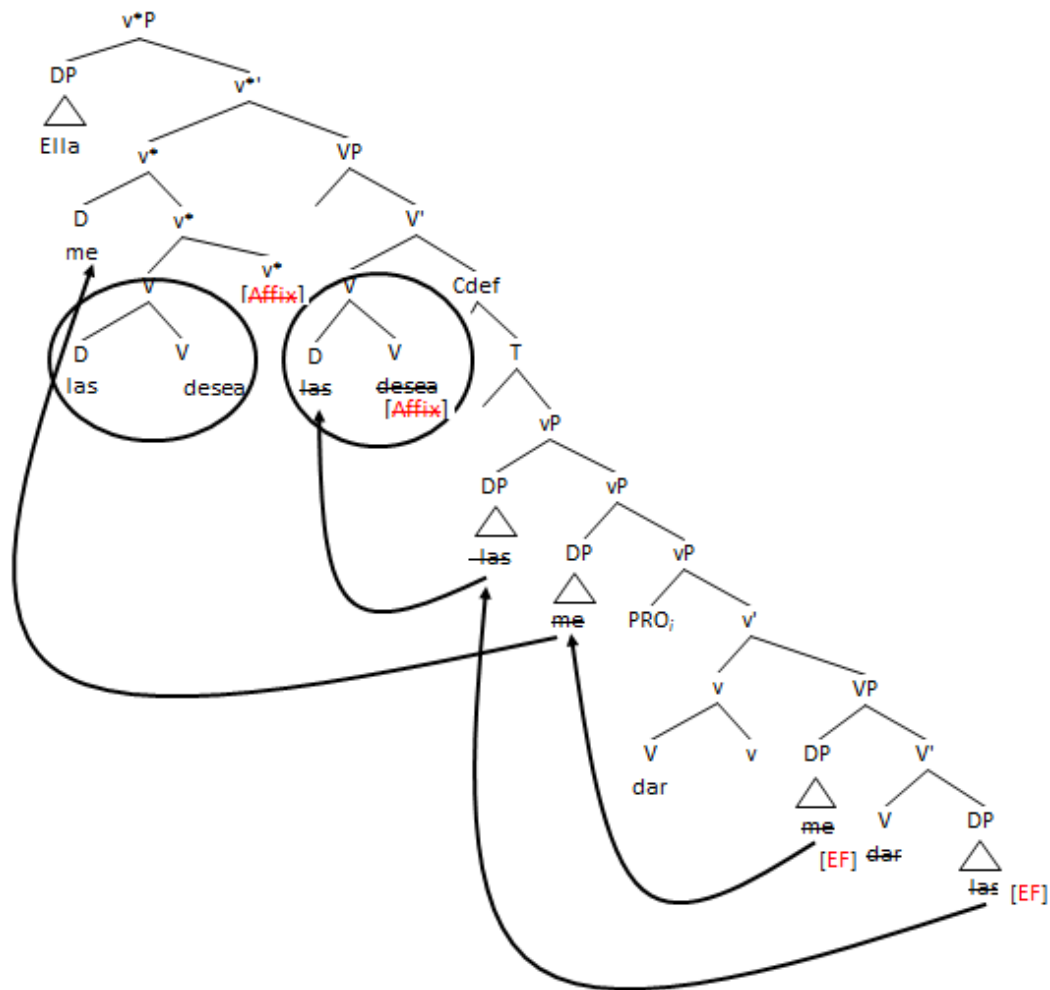

The key step highlighted in Fig. 5.14 is that the DO clitic occupy the highest Edge position in the lower phase. This happens because the DO is the second goal probed by the lower *v*, and consequently the first goal probed by the finite verb. It thus assigned accusative Case.⁵

5.6 Enclisis

One question that naturally arises from the phase-based analysis of clitic climbing posited above (Sec. 4.5) is how to derive the non-clitic climbing versions of the two sentences in (14) and (15), that is, the corresponding enclitic forms in (16):

(16) a. Ella quiere hacerlo.

She wants do._{INF} it._{ACC-MASC}

“She wants to do it.”

b. Ella quiere dármelas.

She wants give._{INF} me._{DAT} them._{ACC-FEM}

“She wants to give me them.”

One recently postulated solution to enclisis within the framework of Phase Theory is found in Roberts’s (2010a) analysis of clitics in Romance, reviewed in depth in Chapter 4 of the present work. According to Roberts, movement of the clitic (i.e., cliticization via incorporation) should be an obligatory operation, even when the clitic surfaces enclitically (Roberts 2010a: 64). As such, to derive enclisis, he must posit subsequent movement of the infinitive over the moved clitic(s). He attributes the original implementation of this operation to Kayne (1991), who assumes that enclisis obtains via ‘long movement’ of the infinitive over the clitic(s), just below T.

⁵ Recall that *v* has full phi-features but no Case feature. Partial Agreement with the IO values *v*’s number and person features, while subsequent Agreement with the DO’s gender feature fully deletes that lower probe’s uninterpretable features.

Roberts further speculates that infinitives can move over *v* since they represent a ‘neutralized category’, not ‘true verbs’ (Roberts 2010: 84)—hence avoiding a Minimality violation. This would yield the following structure in (17), for the embedded clause after movement of the clitic to the edge of the *v** phase in example (16a), with the moved Root/infinitive in bold⁶:

(17) [Cdef [T [**V_i** + **Inf** [*v**P lo_j[*v**P Ella [*v** [VP [_i]]]]]]]]]

(Roberts 2010a: 84).

As long as the clitic reaches the edge of the phase, it is in position to be seen by the higher finite verbal probe and assigned Case, via Long Distance Agreement. Hence, under Roberts’s (2010a) approach, clitic climbing remains optional, but clitic movement to the phase Edge is not. We assume that his analysis in (17) can be repeated for intervening verbs, such as in (18):

(18) Ella desea poderlo hacer.

She wants able._{INF} it._{ACC-MASC} do._{INF}

“S/he wants to be able to do it.”

As the most embedded clause is defective, so are higher intermediate verbs in a clitic climbing sequence. As such, their phase heads can partially agree with and attract the clitic to their Edge, but not deactivate it (since they too lack the Case feature). In (18), the infinitive *intentar* moves over the clitic and Case is assigned as normal by the matrix *v**. However, what happens when the clitic does not climb to the intervening verb in a three main-verb string? Consider (19):

(19) Ella desea intentar hacerlo.

⁶ It should be noted that in Roberts’s (2010a) analysis, enclisis involves incorporation of the clitic on to infinitival *v**, as where the bracketed structure in (17) reflects the assumption of this work that clitics move as DPs to first reach the phase edge and become visible to finite verbs, to which they then incorporate upon Case valuation.

She wants try._{INF} do._{INF} it._{ACC·MASC}

“S/he wants to try to do it.”

Here, the clitic *lo* could only make it overtly to the edge of the lower phase, with the intervening phase head associated with *intentar* standing between it and the matrix *v**. The clitic must make it to the edge of the intermediate verb though to be visible to the finite probe. As such, we would need to posit silent movement to the edge of the second infinitive (akin to cyclic wh-movement in which intermediate copies are not pronounced). Regardless of where the clitic is pronounced, it must end in a structural position where it can be assigned Case for the derivation to go through.

A second, alternative approach to enclisis is to assume that infinitives can sometimes enter the derivation with Case features on them. When they possess Case, they are not defective, can Agree with the clitics in their domain, and thus license them *in situ*. Under this second approach, clitics need not move if they can be valued for Case and deactivated in argument position. We find the non-movement alternative to enclisis conceptually simpler and more elegant, and will for that reason adopt it here. Therefore, we posit the structure in Fig. 5.15, for the derivation of the sentence in (20), where the clitic does not climb:

- (20) Ella desea hacerlo.
she wants do._{INF} it._{ACC·MASC}
“She wants to do it.”

Figure 5.15: Derivation of Enclisis in *Ella desea hacerlo* (‘She wants to do it’)

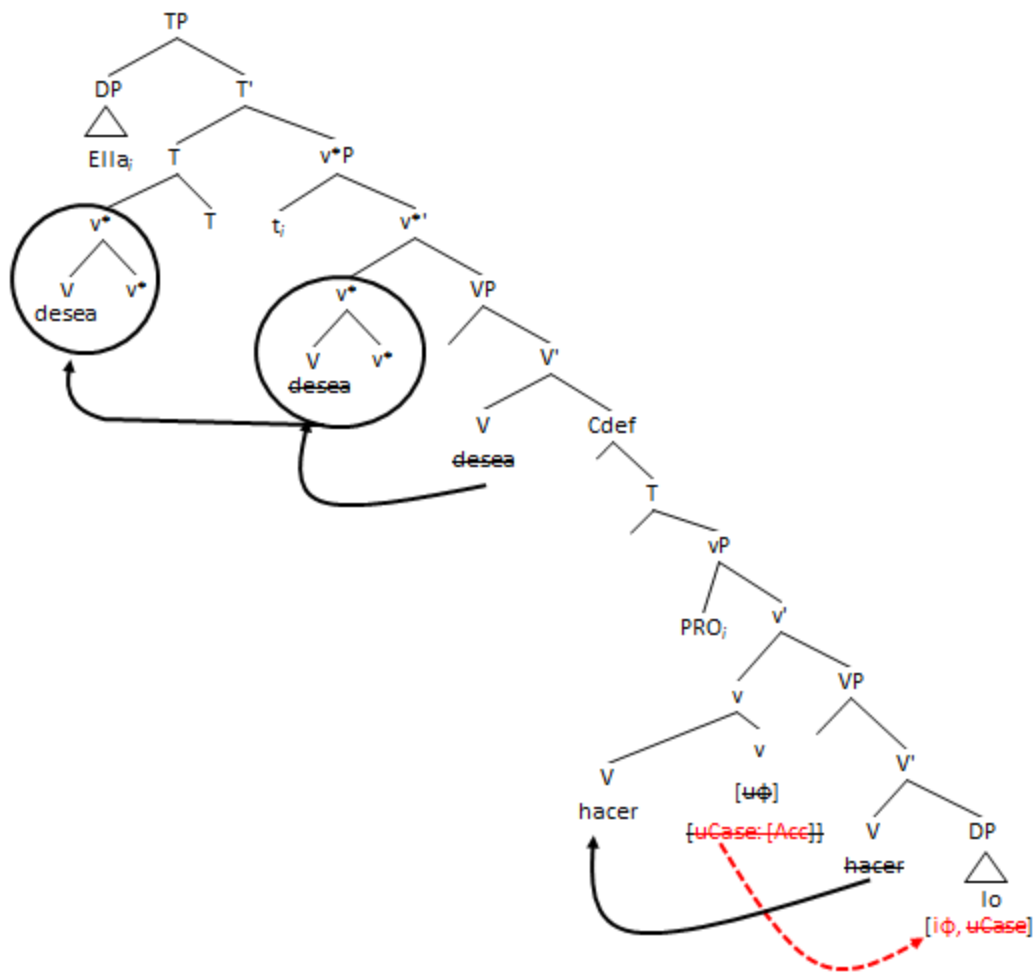

In Figure 5.15, the embedded infinitive *hacer* ('do') enters the derivation with an uninterpretable Case feature valued +Acc. It can, therefore, license the clitic *lo* in its domain by valuing the Case feature of the pronoun. With its Case already assigned in the lower v-phase, it need not escape to the Edge of the phase to become visible to higher probes. Furthermore, we assume the infinitives in Spanish may not take the feature of +Affix from the numeration into the derivation. Therefore, upon Agreement with the infinitive, the clitic stays *in situ*, as the motivation for clitic movement in our proposal is to value and delete the +Affix feature on verbs. To derive enclisis on the middle verb of a three-verb sequence, such as in the example in (18) above, we posit the following structure, outlined in Figure 5.16:

Figure 5.16: Derivation of *Ella desea poderlo hacer* ('She wants to be able to do it')

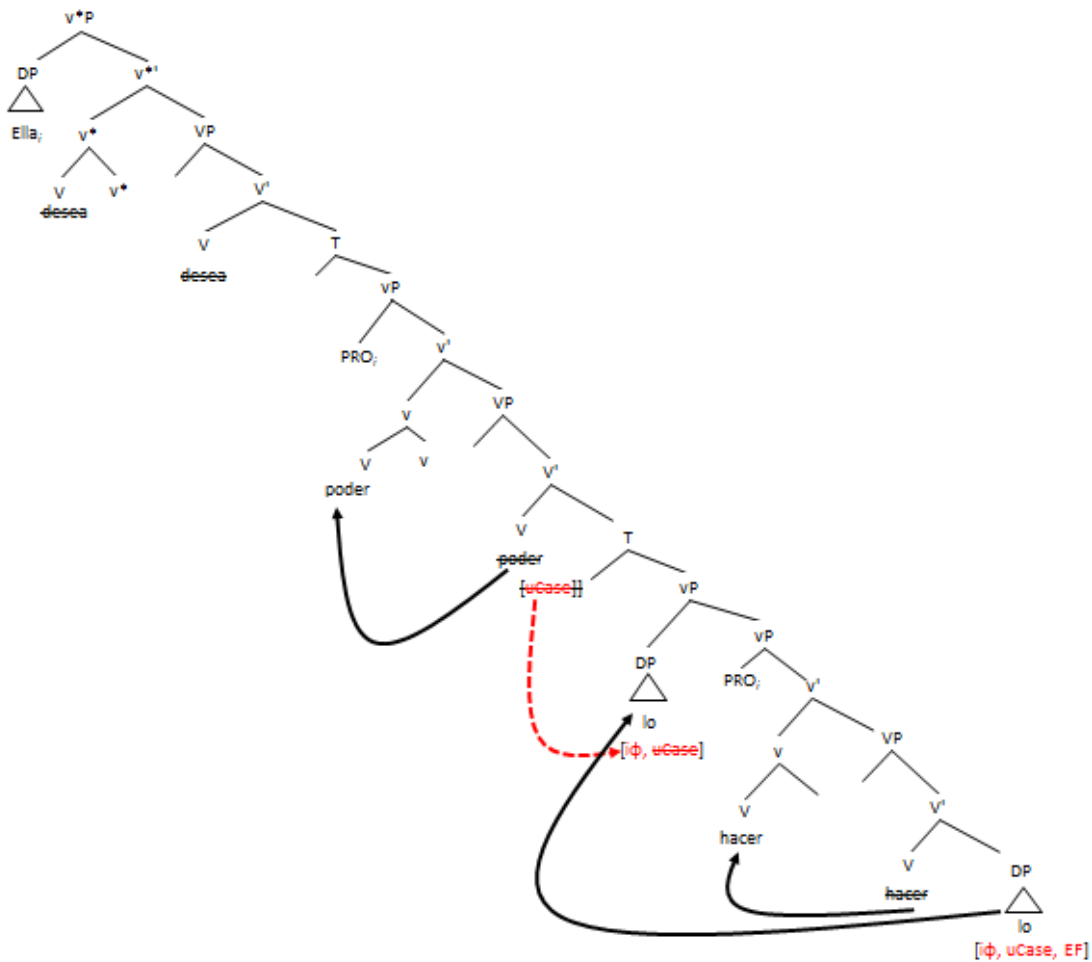

In Figure 5.16 above, the clitic *lo* moves as a maximal element to the edge of the lower phase. This is because the verb *hacer* carries no Case feature with which to value the clitic. Hence, the clitic must enter the derivation with an Edge feature to escape the bottom v-phase. The middle infinitive *intentar* ('try') takes the Case feature from the numeration and thus is able to enter into an Agree relation with the clitic, which now sits in [Spec, vP] of the lower phase. The Case feature on *intentar* sees through defective C/T, and Agrees with the clitic, assigning it accusative Case. As there is no Affix feature on infinitives in Spanish, the clitic stays in the position it receives Case, and PF requirements on the clitic force it to be pronounced at the end

of the adjacent infinitive, *intentar*. Enclisis under this account thus involves no special mechanisms or the postulation of new categories such as Inf Phrase, but rather follows from the fact Spanish infinitives may or may not select Case features from the numeration. When they take Case features, enclisis obtains, as we can see in the derivation in Fig. 5.16. With the mechanisms responsible for clitic climbing in place, let us finally return to the core arguments for putting Case features on object clitics. As we will see in section 5.5, the postulation of Case features on these elements is most convincingly suggested by clitic behavior in a complex array of ECM/causative constructions in Spanish.

5.7 Clitic Climbing in ECM Constructions: The Case for Case

Recall that one strong empirical argument in favor our syntactic approach to clitics involved sentences with three clitics, in which ‘spurious *se*’ was not allowed to occupy the position of genuine, inherently reflexive *se*. This was observed by Cuervo (2013), who created the following hypothetical exchange between two speakers to illustrate the point:

- (21) –Me le llevé el auto (a Emilio)
me._{REFL} him._{DAT} I took the car to Emilio
“I took Emilio’s car for myself.”
--*¿En serio, se te lo llevaste?
in seriousness, him._{DAT} you._{REFL} it._{ACC-MASC} you took
“You really took it from him for yourself?”
(Cuervo 2013: 198)

I made him_{.DAT} write_{.INF} the letter

“I made him write the letter.”

In accordance with the Uniform Theta Assignment Hypothesis (UTAH) of Baker (1988), which maintains that each theta-role assigned by a particular kind of predicate is canonically associated with a specific syntactic position, the clitic *lo* in (23) should originate as the agentive predicate-internal subject of *escribir* in [Spec, v*P]. From its External Merge position, the clitic raises to object to attach to the higher ECM verb. We thus sketch (23) in Fig. 5.17:

Figure 5.17: Derivation of *Yo lo hice escribir la carta* (‘I made him write the letter’)

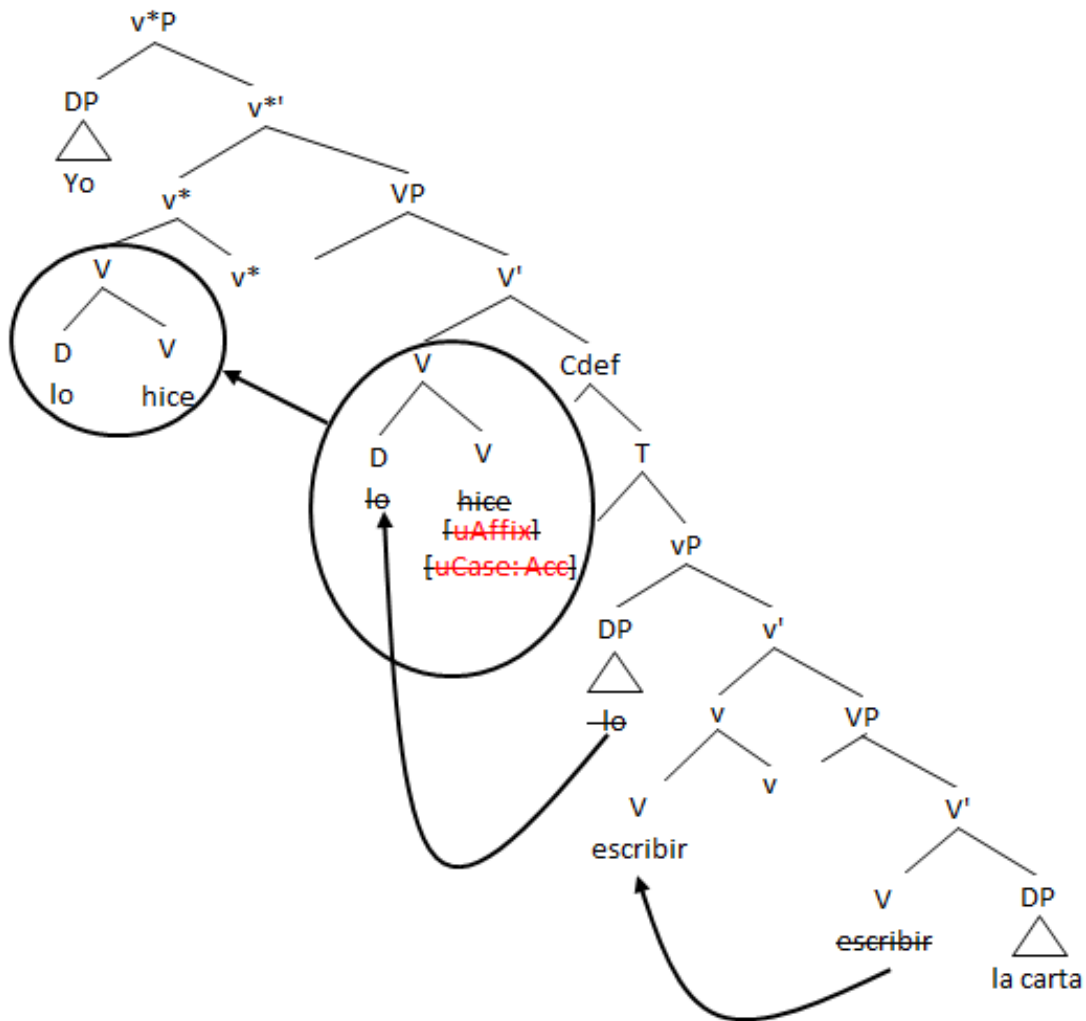

Fig. 5.17 above shows the embedded subject clitic raise to incorporate as a head into the finite causative verb *hice* ('I made'). *Hice* not only enters the derivation carrying a +Acc Case feature, but also carries the +Affix feature needed to attract the clitic. Obviously, the clitic cannot stay in its theta position, because of the phonological requirement that object clitics attach to verbal hosts in order to be licensed at PF (cf. Raposo and Uriagereka 2005). In addition to the PF requirement, we predict that the clitic in this construction must also move to value its abstract Case feature on the higher finite verb. This prediction seems to be borne out when we add another clitic to the ECM mix in Spanish. Observe the examples in (25):

- (25) (a) Yo lo hice lavarla. (la= *la alfombra*, 'the carpet')

I him_{.ACC-MASC} made wash_{.INF} it_{.ACC-FEM}

"I made him wash it."

- (b) Yo se la hice lavar.

I him_{.DAT} it_{.ACC-FEM} made wash_{.INF}

"I made him wash it."

(Strozer 1976: 363)

As we can see from the above alternation, a crucial distinction between clitic climbing in 'restructuring' sentences (see section 5.5) and ECM constructions is that in the former, accusative and dative clitics must move or remain *in situ* together. In the latter, embedded subject clitics can move up and leave the object clitic(s) below. It must be noted, however, that a configuration like (25b), where both clitics move to the higher verb, is only possible when one clitic is marked for dative case and the other accusative—our first indication of a Case theoretic constraint. We derive (25b) in Figure 5.18 below:

Figure 5.18: Derivation of *Yo se la hice lavar* ('I made him wash it')

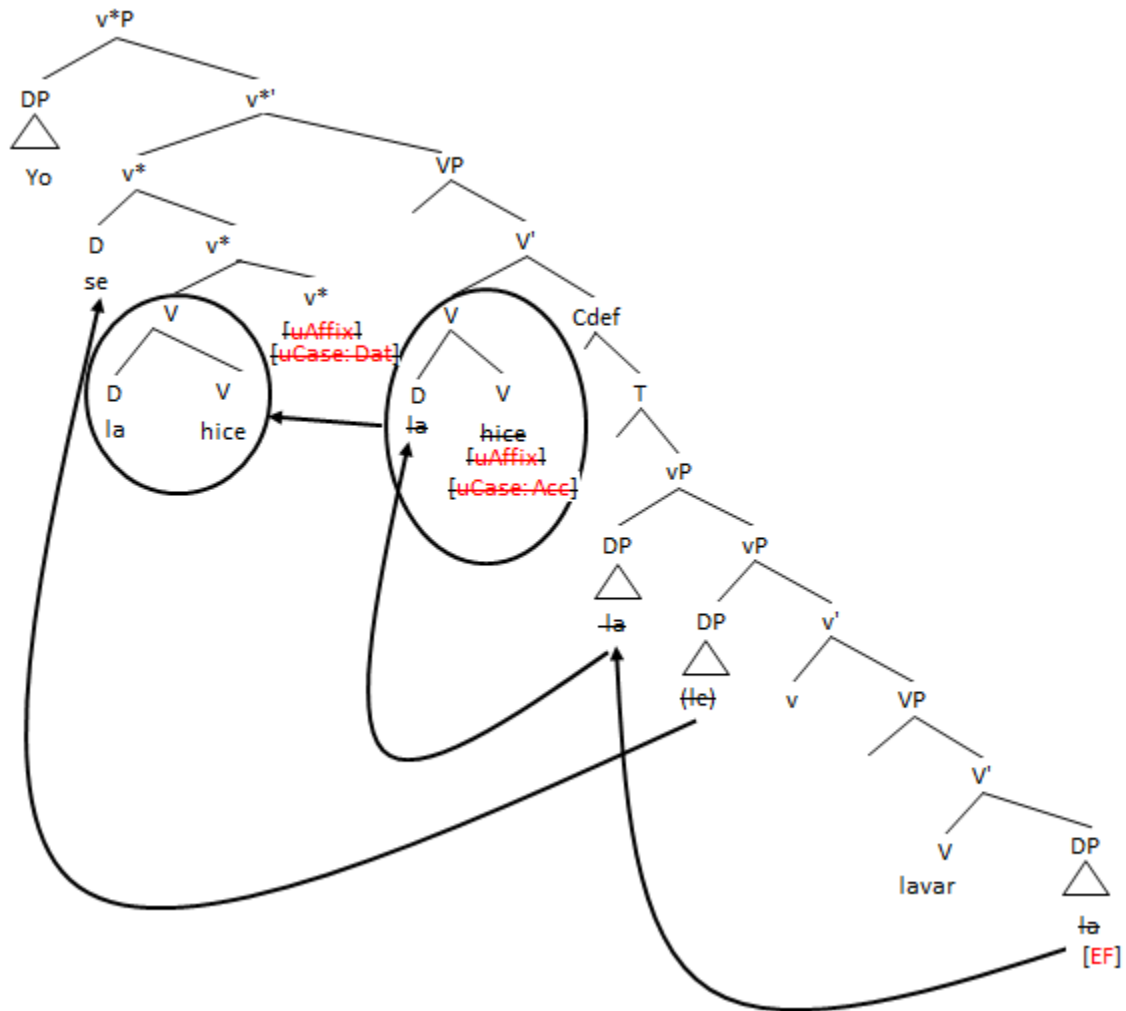

In Fig. 5.18, the embedded object clitic *la* first moves to the Edge of the lower v-phase, because the infinitive *escribir* ('write') has no Case feature with which to value it. The embedded object clitic thus gets internally merged into a position structurally higher than the theta position of the embedded subject clitic before finite v*-level operations take place. Upon the construction of the causative verb phase, Inheritance of features by the finite V from v* makes that Root the first head to probe. Accordingly, the first goal it finds in its domain is the object clitic *la*, which it assigns accusative Case to and attracts via the Affix feature. Once the DO clitic gets valued by the higher finite verb, its Case feature gets deleted from all accessible copies, allowing the clitic

subject of the embedded vP to be seen by higher probes. The next head to probe is v*. This head enters the derivation with uninterpretable phi and affix features, as well as an uninterpretable +Dat Case feature, which it must delete by LF. v* searches its domain and finds the embedded subject clitic, which still carries a uCase feature. These two heads enter into an Agree relation, the embedded subject is valued with dative Case, and is attracted to v* by the Affix feature. In the derivation outlined in Fig. 5.18, we assume that there is only one dative Case slot on the verb and one accusative Case slot, v* and V, respectively. Accordingly, (26b), where both clitics in the cluster are valued for accusative Case, is ungrammatical.

- (26) (a) Yo lo hice lavarla.
 I him.ACC.MASC made wash.INF it.ACC.FEM
 “I made him wash it.”
- (b) *Yo lo la hice lavar.
 I him.ACC.MASC it.ACC.FEM made wash.INF
 “I made him wash it.”

Two accusative-marked clitics cannot agree with and cliticize to the same verb—as structural accusative Case cannot be assigned twice by the same verb (cf. Richards 2013). Nevertheless, the illicit string in (25b) is equally ruled out by the morphology, since two accusative clitics never appear pronounced together. Spanish morphology, on the other hand, has no problem yielding clitic clusters with two dative forms, as in sentences with ‘speaker’ ethical datives:

- (27) Me le_i dieron un helado (al niño_i) (*a mí).
 me.SPK him.DAT they gave an ice cream to the boy to me
 “‘They gave the boy an ice cream on/for me.’”

As we observed in Chapter 2, there are good reasons to assume that speaker dative clitics lack abstract Case, since they cannot be doubled or replaced by a strong DP. Observe what happens though when we try to lift the embedded dative argument clitic in (28b):

- (28) (a) Yo le hice escribirle.
I her.DAT made write.INF him.DAT

“I had him write to her.”

- (b) *Yo se le hice escribir.
I him.DAT her.DAT had write.INF

“I had him write to her.”

(Strozer 1976: 366).

(28b) appears to show that abstract dative Case cannot be assigned to both clitics by the finite verb. This is expected if dative Case is a feature on the verb that can only be assigned to one internal argument. In the sentences where two clitics raise to object, the embedded object occupies the accusative slot on the finite verb, while the embedded subject takes the remaining dative Case. This is confirmed by ECM constructions with multiple embedded objects. When there is an embedded IO present in the structure, it must stay below:

- (29) (a) Él te hizo lavármela.
He you.CL made wash.INF me.DAT it.ACC.FEM

“He made you wash it for me.”

- (b) *Él te me la hizo lavar.
He you.CL me.DAT it.ACC.FEM made wash.INF

“He made you wash it for me.”

(Strozer 1976: 366)

(c) Me hizo devolvérselo.

me.CL made return.INF her.DAT it.ACC.MASC

“He made me return it to her.”

(d) *Se me lo hizo devolver.

her.DAT me.DAT it.ACC.MASC made return.INF

“He made me return it to her.”

(*Nueva gramática de la lengua española* 2009: 1240)

The fact that embedded subject and indirect object clitics are in complementary distribution suggests that they target and agree with the same feature in the higher clause. That feature, as we have suggested, is dative Case. Therefore, in all constructions in which two clitics move to the higher clause, an embedded subject and an embedded IO both vie for dative Case. And since dative Case is an uninterpretable feature on nouns, then we can likewise conclude that there is only one dative Case position (or feature) per agreeing verb to value that Case on nouns, as there is only one accusative feature to value/delete that Case.⁷ We formalize this in (30):

- (30) Each type of structural Case (e.g. accusative, dative) may only be assigned once per agreeing verb.

This provides a principled explanation to extend upon the descriptive generalization of the *Real academia* that two referring clitics in a cluster cannot be of the same grammatical case: (cf. *Nueva gramática de la lengua española* 2009: 1239).⁸ Interestingly, though, there is a further restriction on these structures that slightly complicates matters. That is, the embedded IO clitic is

⁷ In constructions where both embedded object clitics stay below, such as (29c), *Me hizo devolvérselo*, we put Case features on the embedded infinitive, to license the lower clitics *in situ*, as explained in section 5.4 in the discussion of enclisis.

⁸ “*No pueden formar parte de un grupo de pronombres atónos dos pronombres con el mismo caso, sea cual sea el verbo al que modifiquen.*” (There cannot be in a group of weak pronouns two pronouns with the same case, regardless of which verb they modify).

banned altogether from appearing on the higher verb, even when it accompanies an accusative-marked subject clitic, as in (31b), or when it moves with the DO over a lexically unspecified subject (i.e., PRO), as in (31d):

- (31) (a) Yo la hice escribirle.

I her_{.ACC.FEM} made write_{.INF} him_{.DAT}

“I made her write to him.”

- (b) *Yo se la hice escribir.

I him_{.DAT} her_{.ACC.FEM} made write_{.INF}

“I made her write to him.”⁹

(Strozer 1976: 364)

(*Nueva gramática de la lengua española* 2009: 1241)

- (c) Oí (a alguien) decírselo.

I heard (to someone) say_{.INF} her_{.DAT} it_{.ACC.MASC}

“I heard someone say it to her.”

- (d) *Se lo oí decir.

her_{.DAT} it_{.ACC.MASC} I heard PRO say_{.INF}

“I heard someone say it to her.”

(*Nueva gramática de la lengua española* 2009: 1241)

What our proposed rule in (30) fails to explain is why an IO clitic in these sentences cannot move into the higher clause under any conditions. If the only restriction on this set of movements is related to available Case assignments, then there should be no problem lifting the

⁹ As was observed above, (31b) is grammatical on the reading corresponding to *Yo le hice escribirla* (“I made him write it.”)

clitics together in (31). We leave this puzzle unsolved for the moment, since we have not yet finished the case for Case. Now we turn to the famous SSC effects involving clitics.

5.8 Object Clitics and Minimality Effects

Observe what happens when we try to raise the embedded object clitic when the embedded subject is a full DP (*el médico* ‘the doctor’). The result is Kayne’s well-known observation that an SSC violation is incurred in such constructions:

- (32) *Pedro lo hizo a Juan leer *t_{lo}*.
Pedro *it*._{ACC.MASC} made to Juan read._{INF}
“Pedro made Juan read it.”

In current theoretical terms, the SSC reduces to Minimality. The DP *a Juan* counts as an intervener since, given our Case-based assumptions, it is as richly specified as the clitic in terms of features. Recall Rizzi’s formulation of Relativized Minimality:

- (33) Relativized Minimality (revised): in the configuration
...X...Z...Y...

A local relation (e.g., movement) cannot hold between X and Y if Z intervenes and Z fully matches the specification of X in the relevant morphosyntactic features.

(Rizzi 2013: 179).

Given the definition in (33), we expect that the intervening *a Juan* and the clitic *lo* are specified for nominal phi-features and a Case feature. Movement of *lo* over the intervening subject thus yields a minimality violation. Recall that SSC effects can be circumvented though, in

constructions where the lower verb appears in front of the embedded subject. Verb inversion seems related then to the fact that the clitic can move to the higher clause, as in (34):¹⁰

- (34) Pedro lo hizo leer a Juan $t_{leer} t_{lo}$.
 Pedro it._{ACC.MASC} made read._{INF} to Juan
 “Pedro made Juan read it.”

A similar pattern obtains with clitic phenomena involving *+wh*-elements in ECM constructions.

Take the sentence in (35):

- (35) ¿A quién María nos vio examinar?
 To whom María us._{CL} saw examine._{INF}
 “Who did María see us examine?”/
 *“Who did María see examine us?”
 (Quicoli 1976: 212)

The above sentence is only grammatical if the clitic *nos* is the embedded subject of the lower infinitive *examinar*. The reading in which the *wh*-phrase is the embedded subject is impossible. Quicoli attributes this to the SSC as well. In his outline of the derivation, the clitic cannot move past an intervening *a quién* in argument position. Only when *nos* starts in subject position, and the *+wh* in embedded object position, are the movements entailed in (36) licit:

- (36) ¿A quién María nos vio t_{CL} examinar t_{WH} ?

To reformulate Kayne’s original insights within a framework of features, we posit that the *wh*-word values and deletes its Case feature in embedded object position, and then moves around the clitic, since it contains a *+wh* feature not possessed by the clitic (RM allows this), and then successive-cyclically from phase edge to phase edge. The embedded subject, the clitic, still needs

¹⁰ Recall that this order is permitted in some dialects, such as Mexican Spanish. In standard Spanish, the dative-marked clitic must accompany the accusative-marked embedded DO clitic on the higher verb, e.g., *Yo se la vi examinar al médico*.

Case, but can move around intervening copies of the question word, since its Case feature was deleted below, in External Merge position. In order for reading to obtain where *María* is seeing someone examine us, the clitic must stay below in the embedded clause, as in (37):

- (37) ¿A quién_i *María* vio [t_i examinarnos]?
 to whom *María* saw examine._{INF} us._{CL}
 “Who did *María* see examine us?”

This follows naturally from Relativized Minimality if the intervening trace copy of the *wh*-word still has a Case feature to be valued—at that point, it IS as richly specified as the clitic that would try to move around it to value Case on the ECM verb. Since Relativized Minimality blocks this move, the clitic must instead get Case from the infinitive. In sum, the classic clitic examples involving the SSC can be explained via the featural definition of Relativized Minimality, including relative clauses in configurations that mirror the *wh*-questions above:

- (38) a. El hombre que *María* nos vio t_{CL} examinar t_{que} desapareció.
 the man that *María* us._{CL} saw examine._{INF} disappeared
 “*The man that María saw us examine disappeared.*”/
 * “*The man that María saw examine us disappeared*”
 b. El hombre que_i *María* vio t_i examinarnos desapareció.
 The man that *María* saw examine us._{CL} disappeared
 “*The man that María saw examine us disappeared.*”

This set of data adheres to the same principles enumerated above—*que* is a strong relative pronoun (determiner) that carries a Case feature which it must value and delete, and thus is capable of yielding RM effects with clitics. Our Case-based account thus appears on the right track, as it captures the complex set of clitic facts related not only to their distribution in Spanish

in raising to object constructions (where at most three arguments need to be assigned object Case), but also in configurations in which Minimality is standardly considered applicable (i.e., SSC examples). None of these facts can easily be accounted for if clitics in Spanish are base-generated verbal agreement morphology.

Furthermore, we are now in a position to answer the question proposed in (1b), why clitics must move as minimal and maximal elements. In our model (exemplified visually in Figure 5.18), clitics must move as maximal elements when the verb in their immediate domain is partially defective, hence lacking a Case feature. If the object clitic has more features than a c-commanding verbal probe, cliticization cannot occur, following Roberts's (2010a) implementation of head movement in bare phrase structure. Therefore, in cases where the clitic's Case feature is not matched and valued by the infinitive, the clitic must move to the phase Edge as a maximal element, since the incorporation operation is blocked. Clitics only incorporate when they are a featural subset of the probe they agree with, and this only happens when the verb enters the derivation with a Case feature, to match the clitic. In this way, we have preserved Roberts's notion of defective goals and explained why clitics only incorporate when defective. However, this still does not explain why embedded IO's cannot move to the higher clause in ECM/causative structures, as we observed in the examples in (31). This mystery, it turns out, is also tied to Case and Minimality considerations.

5.9 The Clitic Left Below: Out-Dative

Recall from the clitic climbing data discussed in section 5.7 that under no conditions may an embedded indirect object clitic move up in an ECM construction, as in (39b):

- (39) (a) Yo la hice escribirle.
 I her_{.ACC.FEM} made write_{.INF} him_{.DAT}
 “I made her write to him.”
- (b) *Yo se la hice escribir.
 I him_{.DAT} her_{.ACC.FEM} made write_{.INF}
 “I made her write to him.”
- (Strozer 1976: 364)

When we first considered these sentences, the ban on the raising of the IO clitic was a puzzle. But with the aid of additional technical assumptions spelled out since, we can now account for the impossibility of (39b), where *se* refers to the embedded IO, in Fig. 5.19:

Figure 5.19: Failure of Accusative Case Assignment to an IO¹¹

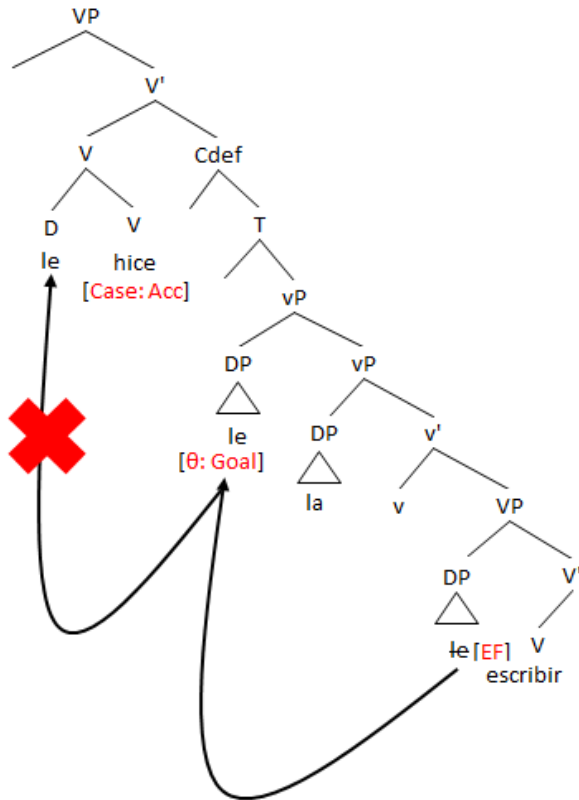

¹¹ This only applies to abstract Case assignment, a narrow syntactic mechanism. Morphologically, of course, indirect objects can be marked with accusative case, as in the English double object constructions and *laísta* dialects of Spain.

Starting with the derivational steps in the embedded clause in Fig. 5.19, assume that the IO clitic has an Edge feature and can make it to the Edge of the vP, above the embedded subject (in 39b). Also assume that the possession of an Edge feature renders RM inapplicable in this case, and there is no blocking effect triggered by passing the embedded subject clitic. Now, given the model of Inheritance outlined in our proposal, the first category to probe is the higher V. V has a Case feature, but can in principle only assign structural accusative Case. Consequently, there is a probe/goal mismatch when V probes the domain of vP and can only see the indirect object. Valuing the embedded indirect object with accusative Case would result in a failure of the Case-assigning mechanism, and the derivation would crash, assuming there is a relationship between abstract Case assignment and the theta roles of the nouns being assigned Case. We can formalize this constraint on Case assignment by syntactic position in a principled manner, in (40):

- (40) Case valuation of direct objects is tied to Probe V, while Case valuation of indirect objects is tied to Probe v*.

This further motivates the existence of each active probe in a framework of Inheritance. Each type of object is associated with a specific probe, in the same way that subjects in finite clause are associated with T, and *+wh* words are associated with C. In our model, each of the four main probes is thus responsible for agreeing with and attracting a different sort of element. This adds to the conceptual elegance and symmetry of the Inheritance approach. Just as *+wh* words are not attracted by T, indirect objects are not attracted by V, nor are direct objects attracted by v*. This explains why the embedded IO cannot raise to object under any circumstances—as the first element that needs to be valued with Case, it must take accusative Case from V or no Case at all. The dative Case feature selected by v* is inaccessible to the lower IO, because Minimal Search doesn't allow V to probe any further than the IO. The embedded subject, on the other hand, can

absorb Dative Case, since it is not thematically identified with Dos or IOs. Unlike true objects, the embedded subject can get valued with either accusative or dative Case. Again, this implies that the theta feature on DOs and IOs figures in Case valuation, preventing a theme from being valued with abstract Accusative Case, and a goal from being valued with dative Case.

5.10 Distinguishing Clitic Movement from that of Doubles

In addition to embedded IO clitics, there is another element that cannot raise to object in structures where multiple elements Agree with the ECM verb. These are the DP doubles, about which much has been written in the literature. However, to our knowledge, no one in the literature has discussed constructions where the movement of the double to a higher ECM-style clause is banned. That is, when the subject of the lower clause in an ECM/causative sentence is a full DP, it cannot move up with a DO clitic:

- (41) (a) *Pedro a Juan lo hizo leer. (lo= *el libro*, ‘the book’)
- Pedro to Juan it._{ACC.MASC} made read._{INF}
- “Pedro made Juan read it.”
- (b) *A Juan Pedro lo hizo leer.
- to Juan Pedro it._{ACC.MASC} made read._{INF}
- “Pedro made Juan read it.”

Nonetheless, when the embedded DP subject is a clitic, as we already know, both clitics move up readily (with verb inversion):

- (42) (a) Pedro se lo hizo leer. (se = le = a Juan)
- Pedro him._{DAT} it._{ACC.MASC} made read._{INF}
- “Pedro made Juan read it.”

That both clitics are allowed to raise to argument position, but not a clitic and a DP, is explained readily by the assumptions entailed in our approach in Figure 5.20, a sketch of the bad derivation that would yield the ungrammatical sentence in (41b):

Figure 5.20: Full Noun Phrase Banned from Raising to Object with Clitic

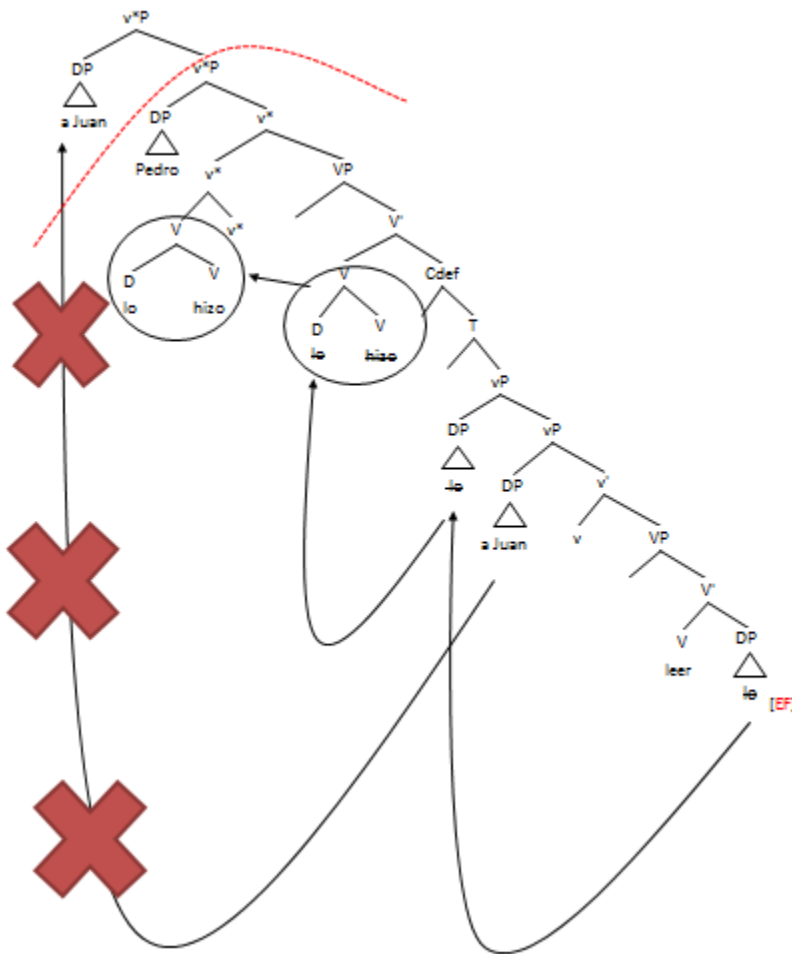

In Fig. 5.20 above, the embedded subject DP cannot move and target [Spec, v*P] of the higher clause because of, once again, Relativized Minimality. Recall that in Phase Theory, each phase is built up before the operations performed in that phase apply. Hence, before v* can establish an Agree relation with the embedded DP and attract it, there is already a predicate-internal subject sitting in [Spec, v*P]. This element IS as richly specified in terms of phi-features as the

embedded DP that would raise to subject upon dative Case valuation. This is an obvious violation of Minimality. Only minimal elements can raise together then, because they only reach the edge of v^* , below the already merged subject of the higher clause. This in turn demonstrates the necessity of the head movement approach (see Figure 5.18). That is, if both embedded subject and object clitics move as maximal elements here, they would likewise be blocked from the upper clause by the subject's $u\text{Case}$ feature, as highlighted in Fig. 5.20.

Furthermore, the ungrammaticality in (41) provides us with another justification of the movement analysis of clitics, as we cannot rely on movement of the double alone to instantiate displacement effects tied to clitic placement (cf. Sportiche 1996, 1999). Raising of the embedded subject double into the matrix [Spec, v^*P], necessarily XP movement, is ruled out in the sentences in (41). This in turn gives us a plausible answer to (1d)—how to distinguish between the movement of these two elements. Clitics, as heads, can target incorporation into v^* , below the offending intervening subject DP in its source position in the matrix clause. Doubles, however, do not have the option of head-to-head incorporation, and their movement into a derived object Case position in the constructions in (41) triggers a Minimality violation. The embedded subject must receive Case *in situ* then when a DO clitic raises to object by itself, as in (43), sketched in Fig. 5.21:

- (43) Pedro lo hizo leer a Juan.
 Pedro *it*._{ACC.MASC} made read._{INF} to Juan
 “Pedro made Juan read it.”

Figure 5.21: Derivation of *Pedro lo hizo leer a Juan* (‘Pedro made Juan read it.’)

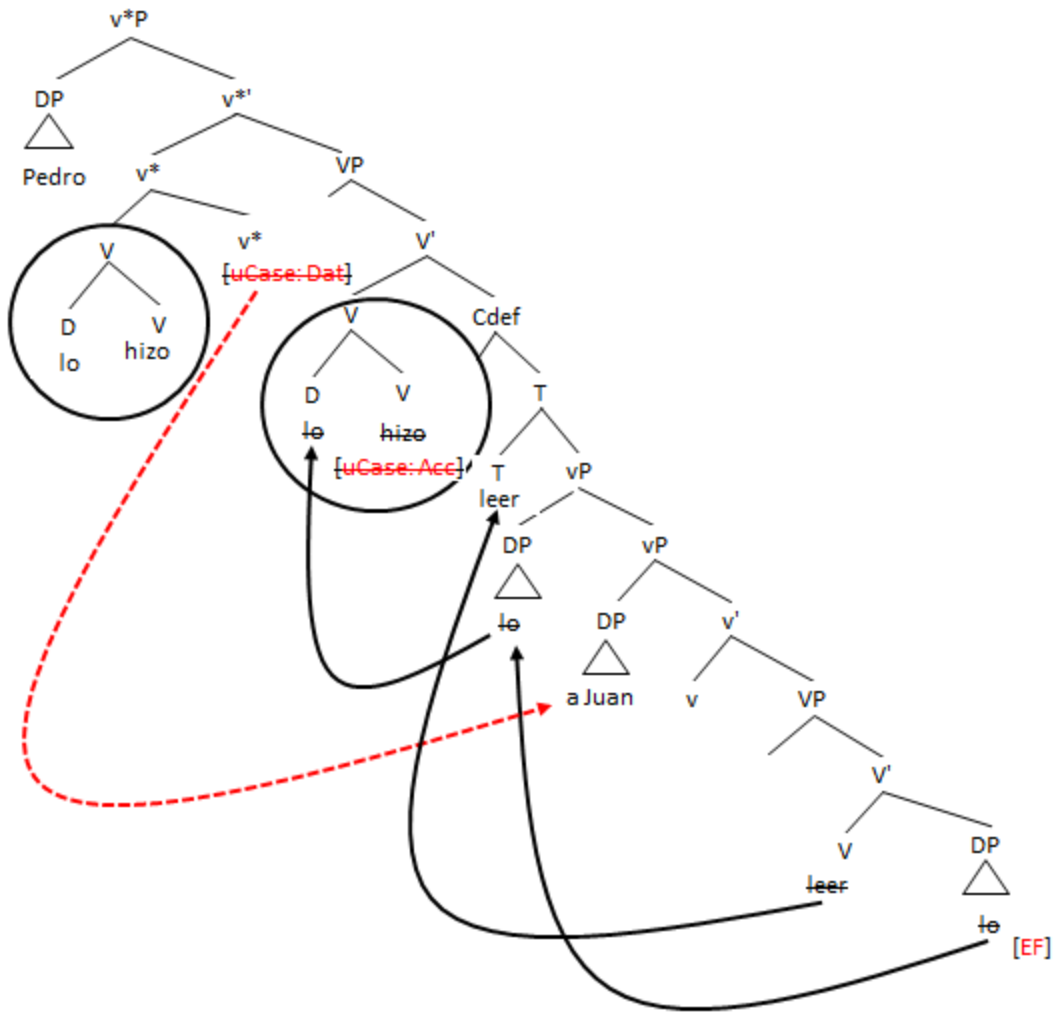

In Fig. 5.21, once the embedded DO clitic receives and deletes accusative Case and incorporates into finite V, the higher v^* probe searches and finds the DP in the embedded clause. As it cannot attract a maximal element into its specifier position, Case valuation proceeds without movement. In other dialects of Spanish, where (43) is unacceptable (cf. Strozer 1976: 371), the embedded subject must raise to object, as a dative-marked clitic, along with the embedded DO clitic:

- (44) Pedro se_i lo hizo leer a Juan $_i$.
 him.DAT it.ACC.FEM I saw examine.INF to the doctor
 “I saw the doctor examine it.”

In these dialects, the embedded subject must raise, and hence be realized as a clitic. Nothing of substance changes though from one dialect to the other, in this case. The crucial observation, which is that the double cannot raise to object with a clitic, is maintained across all dialects.

5.11 When Clitics Block Clitics

The Minimality approach not only allows us to distinguish head movement of clitics from XP movement of doubles, but it also serves to explain intervention effects unrelated to SSC-style configurations. A feature-based Relativized Minimality can account for why clitics cannot cross clitics subcategorized by other verbs, like in examples of the type illustrated in (45)¹²:

- (45) a. Ella me seguía gritándolo.
She me-CL followed shouting it-ACC-MASC
- b. *Ella me lo seguía gritando.
She me-CL it-ACC-MASC followed shouting
“She followed me shouting it.”
(Strozer 1976: 283)

The clitic *lo* is unable to move up to the higher verb in (46b) due to what should now be familiar reasons. In order for *lo* to move to a position where it could get valued with accusative Case by *seguir* would constitute an Relativized Minimality violation, since intervening *me* is as richly specified in terms of features as the moving element. We can clearly visualize how this movement would constitute an RM violation with the sketch in Figure 5.22:

Figure 5.22: Clitic over Clitic Movement Banned by Minimality

¹² Recall that the starred example in (45) is grammatical under the auxiliary ‘continue’ meaning of *seguir*, but not with the main verb meaning ‘follow.’ When *seguir* means ‘continue’, both clitics originate on the lower verb, and move up via the series of movements proposed above for clitic clustering with auxiliaries, like for *Se lo he dicho* (‘I have told her it.’)

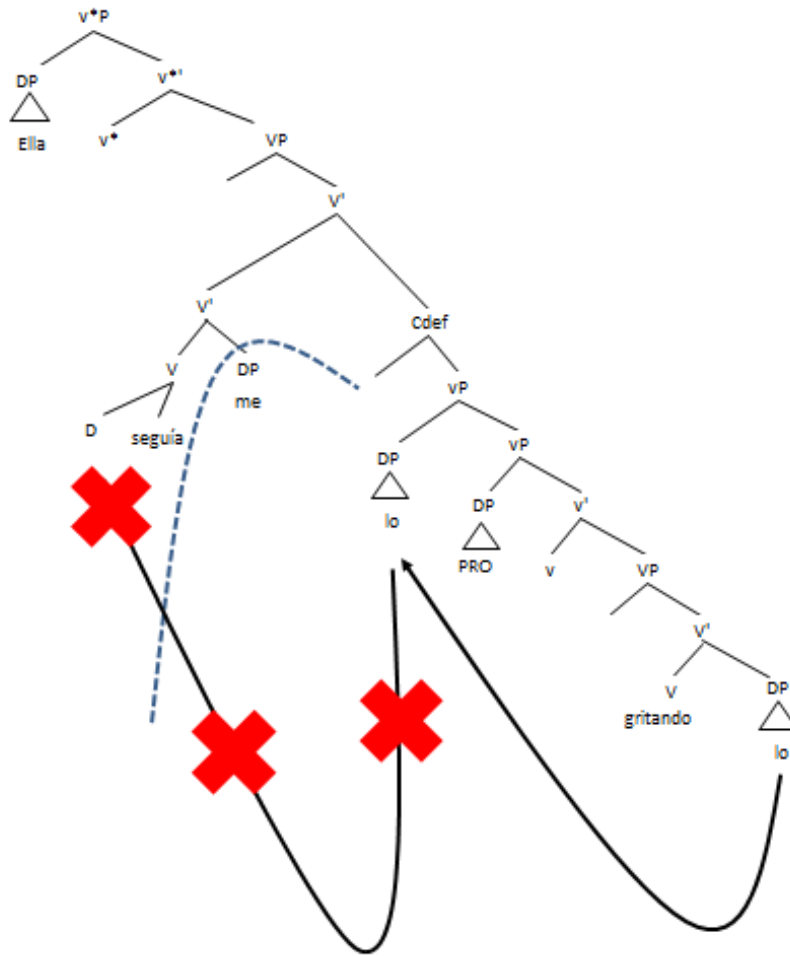

Relativized Minimality explains the intervention effect entailed by the x'ed-out movement in Fig. 5.22 above. The intervening DO *me* has a Case feature and a full set of phi-features. In derivational terms, this configuration is blocked by locality constraints on Search. That is, the Search mechanism on the higher V probe would not even be able to see the lower clitic *lo* because of the intervening clitic *me* in its own domain. Thus, *lo* is impenetrable to the higher accusative Case-assigning probe, and the Agree relation between them is blocked. Regardless of whether we portray the failure of clitic movement in (45b) as an intervention or impenetrability effect, we get the same outcome—the presence of intervening element *me* blocks the movement of *lo*.. In the next section, we will conclude our study of barriers to clitic movement by

discussing configurations that are purely due to impenetrability effects, in each case ruled out by the Phase Impenetrability Condition.

5.12 A Phase Apart: The PIC and Island Effects

The Phase Impenetrability Condition also explains why clitics cannot raise to object when there is an intervening *wh*-word or negative operator. The relevant examples are reproduced from Chapter 2 in (46) and (47) below:

- (46) a) No te sé decir.
pro no you I know tell_{INF}
“I don’t know how to tell you.”
- b) *No te sé qué decir.
pro no you_{CL} I don’t know what tell_{INF}
“I don’t know what to tell you.”
- (47) a) Lo intenta leer.
pro it_{ACC.MASC} intends read_{INF}
“S/he intends to read it.”
- b) *Lo intenta no leer.
pro it_{ACC.MASC} intends no read_{INF}
“S/he intends not to read it.”

These island effects are attributable to the Phase Impenetrability Condition. In our analysis, the (a) sentences are good because the embedded clause is completely defective. Accordingly, C_{def} does not constitute a phase head, nor does it project specifiers. It is completely transparent, has no features, and allows for the clitics on the Edge of the lower infinitive to be probed by the

finite verb above. However, the introduction of a *wh*-word in (46b) and a negative word in (47b) suggests a more complex structure. For the *wh*-word to be licensed, there must be an available [Spec, CP] in the embedded clause. As such, we posit that the embedded clause in (46b) is not defective, but rather a functioning phase head. This is where the PIC comes into play. Upon the merger of the phase head v^* , elements in the complement of C, including T and the clitic in lower phase Edge [Spec, vP], are sent to Transfer.

As we see no mechanism for motivating movement of the clitic to [Spec, CP], there is no way for the higher verb probes to find the clitic and attract it to the finite verb. As such, the PIC mandates that the v^*/V probes can only see as far down as phase head C. Everything below the dotted line in Figure 5.23 is invisible to the verb that would otherwise be able to attract the clitic to value its Case feature, derivation of the ungrammatical (46b):

Figure 5.23: No Clitic Climbing out of a *wh*-Island

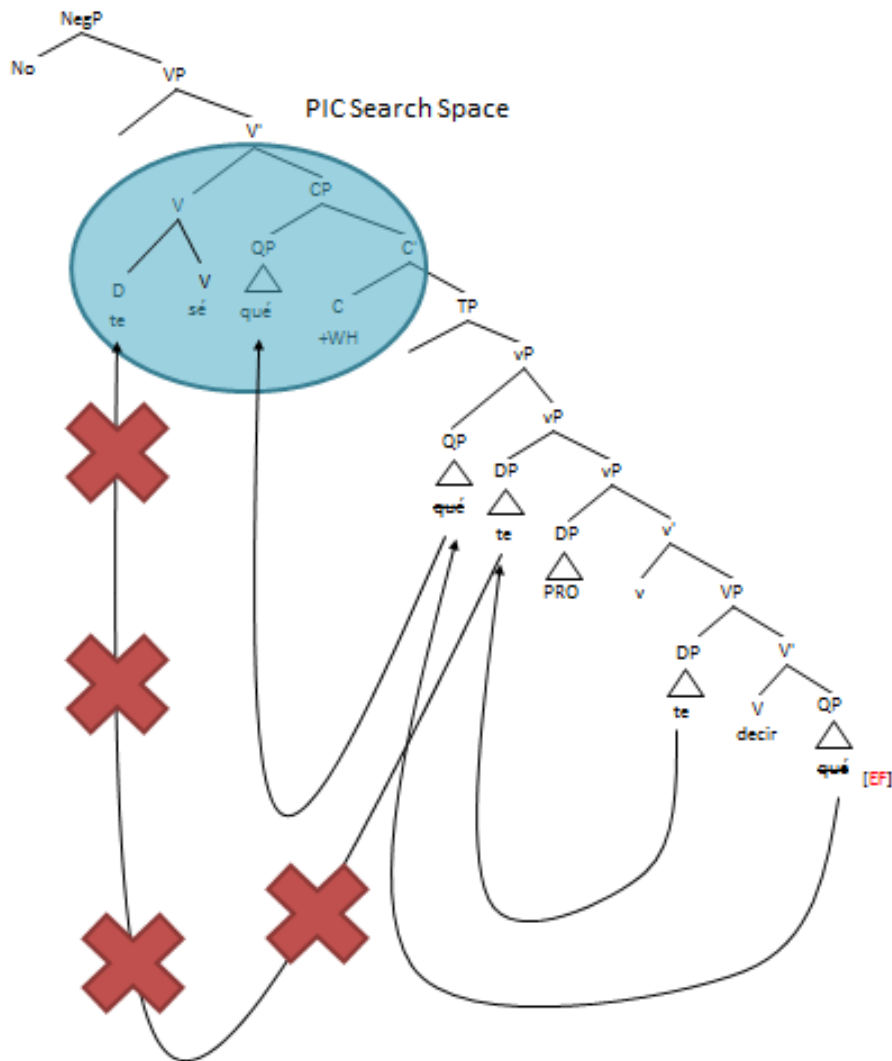

Although the clitic *te* can make it to the edge of the lower phase via partial agreement with *v* in Fig. 5.23 above, there is no feature provided by the grammar of Spanish to allow the clitic to make it to [Spec, CP] in the search space of the matrix V. Consequently, in the good derivation in (46a), there must be Case on the embedded infinitive, to license the clitic *in situ*.

Likewise, the existence of a negative clausal operator in the embedded clauses in the sentences in (47) is tied to the presence of an embedded CP. In Chomsky's account of Inheritance (2008), all of T's tense and agreement features originate on phase-head C, including

negation. This is evident in languages like Spanish which feature negative concord (NC).

Observe the sentences with negation in Spanish in (48) and (49):

(48) a. Nadie salió.

No one left

“No one left.”

b. No salió nadie.

no left no one

“No one left.”

(49) a. María no canta nunca.

María no sing never

“María never sings.”

b. María nunca canta.

María never sings

“María never sings.”

c. *Nadie no canta nunca.

No one no sing never

“No one ever sings.”

d. *Nunca no canta nadie.

never no sing no one

“No one ever sings.”

(Zagona 2002: 23)

These sentences are standardly interpreted to indicate that instead of two negation elements, there is only one locus of negation, *no*, that acts as an operator, binding the negative

element that it c-commands, such as *nunca, nadie*. Negative concord is thus licensed by ‘negative agreement’ between the negative operator and the negative polarity item it licenses. Although the negative operator sometimes appears below the subject, it can also appear above, and it must always precede the verb. Laka (1991) accounts for negation in languages like Spanish by projecting a functional category called NegP above T and below C. Roberts and Biberauer (2011) adapt these observations into a modern framework, and place the interpretable Neg-feature in C (Roberts and Biberauer 2011: 42). Via the operation of Inheritance, T receives the Neg-feature and spells out *no* in Spanish in the inflectional region, explaining the word order in (49a).¹³ If, as Roberts and Biberauer speculate, phase-head C is the locus of clausal negation, then we can explain why clitic climbing is not permitted in a sentence like (50):

- (50) *Ella lo intentaba no comer. (lo= *el perro caliente*, ‘the hot dog’)
She it._{ACC.MASC} tried no eat._{INF}
“She tried not to eat it.”

Figure 5.24: No Clitic Climbing out of a Neg-Island

¹³ Unlike English negation elements *not/n’t* which must always be present to make a negative sentence, Roberts and Biberauer posit that Spanish/Italian *no* is a *PF spellout element*, which need not always be present in the Numeration, such as in *María nunca canta* (‘María never sings’) (Roberts and Biberauer 2011: 42).

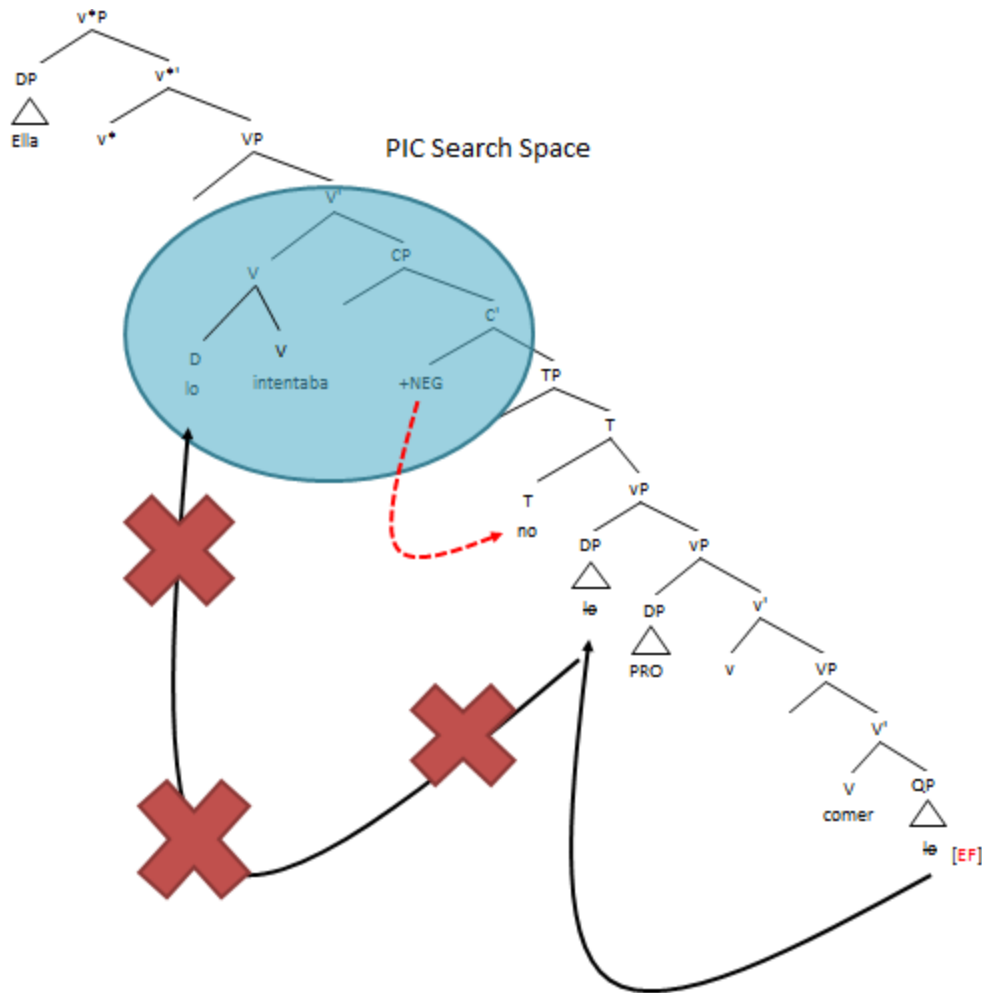

In Fig. 5.24, we see that negation in the embedded clause starts in C and is then inherited by T. However, the clitic is invisible to the higher v^* probe and hence unable to climb because of the intervening CP that must be present to license the negative operator in the embedded clause. This is once again attributable to the Phase Impenetrability Condition, as the Search space of the higher finite verb only extends to the closest phase-head below, phase head C. The negative island forces derivations in which the clitic is valued for Case by the infinitive, such as in (51):

- (51) Ella intentaba no comerlo.
 She tried no eat._{INF} it._{ACC.MASC}
 “She tried not to eat it.”

5.13 Binding of Reflexive Clitics by Phase

The final type of clitic construction discussed in Chapter 2 that needs to be analyzed involves the placement of reflexive anaphor clitics in causative constructions, as in (52):

- (52) a. Juan hizo a los muchachos_i afeitarse_i.
Juan made to the boys shave._{INF} themselves._{CL}
“Juan made the boys shave themselves.”
- b. Juan hizo afeitarse_i a los muchachos_i.
Juan made shave._{INF} themselves._{CL} to the boys
“Juan made the boys shave themselves.”
- c. ?/*Juan se_i hizo afeitarse a los muchachos_i.
Juan made themselves._{CL} shave._{INF} to the boys
“Juan made the boys shave themselves.”

The first construction above in (52a) is derived easily since it involves no movement, with the exception of a possible vacuous raising of the embedded subject *los muchachos* to object position. (52b), on the other hand, requires explanation. How is it, for example, that the anaphor clitic raises above the subject that binds it (i.e., *los muchachos*)? One explanation is the need to value Case. If the embedded infinitive does not enter the derivation carrying a +Acc Case feature, then the embedded anaphor needs to move into the domain of a Case-bearing verb. If we put a Case feature on the matrix verb *hizo* (‘made’), then we can explain why the clitic must raise above the embedded subject. However, as we can see in (52b), the clitic does not make it all the way to the main verb. It apparently stops short, which makes sense if, as an anaphor, the reflexive clitic must be bound in the domain of its antecedent. Assume then that the clitic stays in

the domain of the embedded subject, the embedded clause, but nevertheless becomes visible to the higher Case-assigning verb, shown in Figure 5.25:

Figure 5.25: Derivation of *Juan hizo afeitarse_i a los muchachos_i* (‘Juan made the boys shave themselves’)

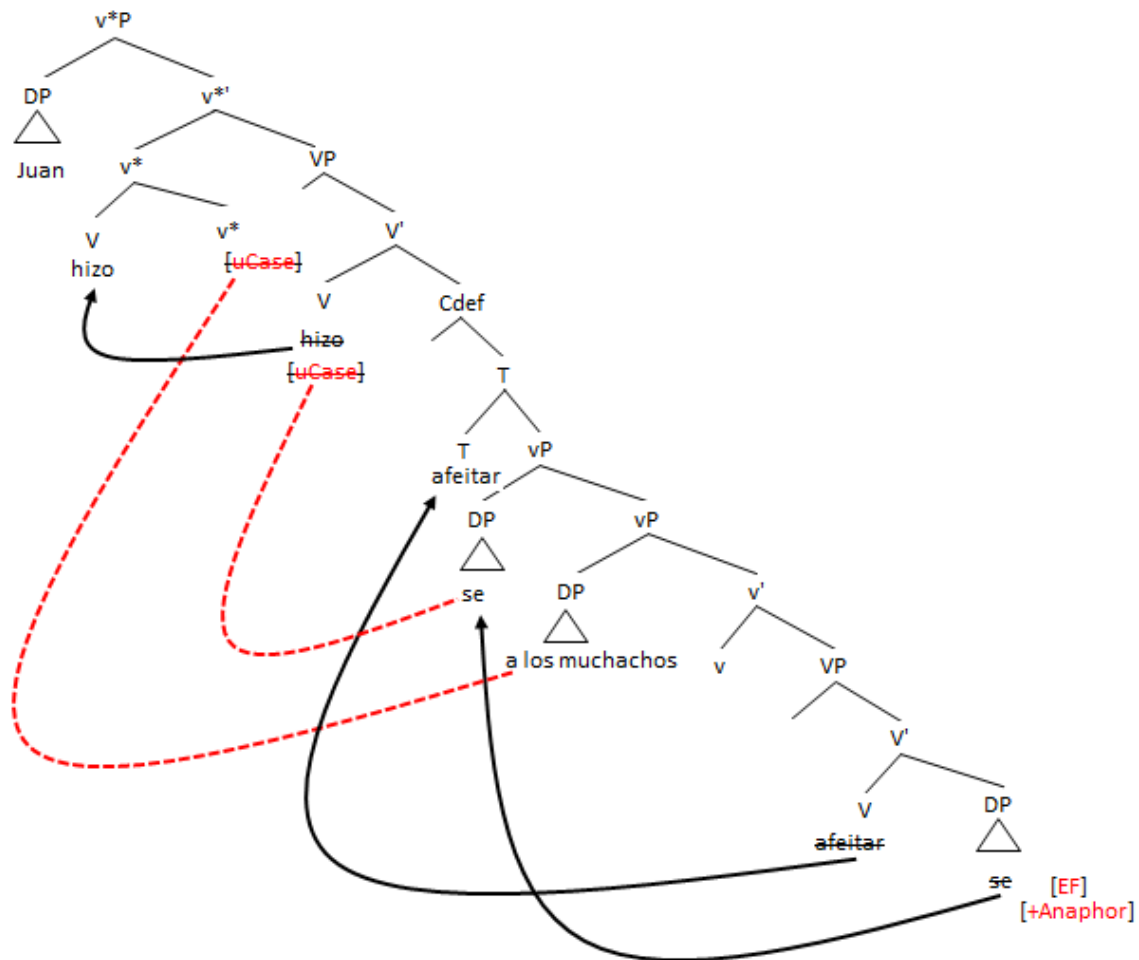

In Figure 5.25, the reflexive clitic *se* moves to the Edge of the lower phase, to become visible to its Case assigner in the main clause. However, it does not move beyond the Edge of the lower clause when there is no uAffix feature on the higher verb. Since the affix feature is the key feature that forces clitic movement, Case assignment to the clitic takes place at a distance. Furthermore, movement of the embedded verb *afeitar* (‘shave’) is necessary for morphological

reasons, for when the embedded clause is Transferred to Phonological Form. That is, movement of *afeitar* is a Last Resort operation, ensuring that the clitic has a phonological host at PF.

Finally, (52c), where the reflexive clitic appears attached to the finite verb, has been dialectally attested, despite being unacceptable in standard dialects. Chomsky (1987) explains the ungrammaticality of (52c) for most speakers by arguing that the anaphor clitic must be bound in the domain of its antecedent subject. However, given the possibility of (52c) in certain dialects, we argue that even if binding takes place in the lower clause, the presence of Case AND affix features on the higher verb facilitates clitic movement there, shown in Figure 5.26:

Figure 5.26: Derivation of ?/Juan se_i hizo afeitar a los muchachos_i* ('Juan made the boys shave themselves')**

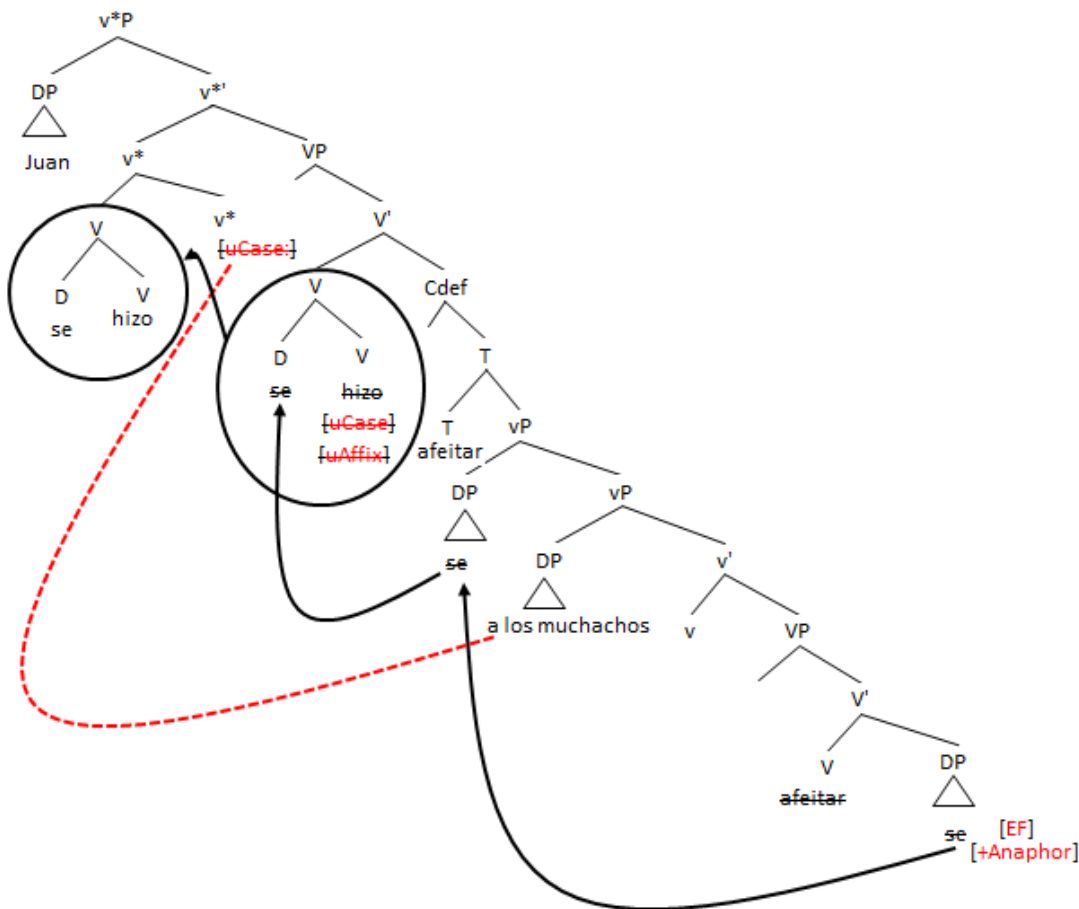

The dialectally attested (52c), as derived in Fig. 5.25, further highlights the need for a movement account of object clitics, as there is no empty category for anaphors under current standard Minimalist assumptions. Therefore, it must be a copy of the reflexive clitic itself that is first bound in the lower clause, and then moves up to value its own Case feature, and then finally the affix feature of the main verb, which can only be valued locally, naturally. The movement of the anaphor clitic beyond the domain of its antecedent parallels movement of ‘picture noun’ anaphors embedded in quantifiers, such as in (53):

(53) Which pictures of himself_i did Mary say that John saw *t_i*?

We assume that the picture phrase in (53) is bound in the first phase in the domain of *John*, and then moves up cyclically, phase by phase, all the way to the CP of the higher clause where it values/deletes its Edge (+*wh*) Feature (cf. Quicoli 2008). As movement of anaphors beyond the domain of their antecedent is obviously possible with *wh*-expressions, we assume that this possibility also exists for anaphoric clitics, to yield structures like (52c).

5.14 Verb Feature Inventory in Clitic Constructions

The object clitic constructions analyzed in this chapter leave us then with the combinatorial possibilities specified in Table 5.1 below, with regard to the features that must or may be selected in the Numeration by probing heads upon entering derivations with clitics:

Table 5.1: Features Selected in the Numeration by Verbs in Clitic Constructions

Verb Type	Subcategorization	Case	Affix	Example
Infinitive	Θ =clitic	+/-	-	(1) Quiero verlo (+Case, -Affix) (2) Lo quiero ver (-Case, -Affix)
	Θ ≠clitic	+/-	-	(1) Deseo poder hacerlo (- Case, -Affix) (2) Deseo poderlo hacer (+Case, -Affix)
Finite	Θ =clitic	+	+	(1) Lo veo (+Case, +Affix)

	$\Theta \neq \text{clitic}$	+/-	+/-	(1) Lo quiero ver (+Case, +Affix) (2) Quiero verlo (-Case, -Affix) (3) Juan hizo afeitarse a los muchachos (+Case, -Affix)
--	-----------------------------	-----	-----	---

The first row in Table 5.1 explains that an infinitive verb head that subcategorizes a clitic may or may not enter the derivation with a Case feature. However, it may never pick up an affix feature from the Numeration, and thus Case-assigning infinitives do not trigger clitic movement. The second row deals with infinitives that do not subcategorize a clitic—that is, the middle infinitive in a clitic climbing sequence.¹⁴ As an infinitive, it may not pick up an affix feature, but it may or may not possess Case. When it does enter the derivation with the object Case feature, it forces the clitic to move to the Edge of the lower verb phase. The next row shows that finite verbs that subcategorize clitics must assign the clitics Case and enter the derivation with the affix feature. Cliticization is thus obligatory on these verbs. Finally, there are finite verbs that do not subcategorize clitics. These verbs may assign Case and attract the clitic, or do neither. Finally, there is the third possibility, discussed in section 5.14, where the finite verb in the matrix clause assigns Case to the clitic, but does not have an affix feature to force cliticization. In these examples, the clitic moves to the Edge of the lower infinitive to get Case, but no higher.

5.15 Concluding Remarks

We have seen in this chapter how by using two simple mechanisms, Relativized Minimality, and the Phase Impenetrability Condition, we can account for all of the conditions on clitic climbing. SSC effects reduce to more general conditions on the movement of any category over an intervening element that is as richly specified as it in terms of features. Relativized Minimality accounts for all such intervention effects—and we observed that clitics, as DPs, are

¹⁴ Assume that *poder* here is a main verb, ‘able to’, rather than auxiliary *can*.

subject to these effects. We demonstrated this fact through a careful study of complex clitic configurations in ECM sentences in Spanish. We also saw that when multiple arguments raise to object, these elements must both be minimal. Non-clitic DPs that raise to object only have one possible landing site, [Spec, VP], associated with the V (accusative) probe. If the stressed DP tries to raise to object with a clitic DO, the intervening subject in [Spec, v*P] blocks the operation, keeping the embedded subject in the lower clause. This provides a justification for implementing cliticization through head-to-head incorporation, and for distinguishing the movement of clitics from the movement of their doubles. Also, our Case-theoretic model built on the Roberts's principle of 'defective goals,' showing that when the clitic has more features than its attractor, movement of the clitic triggered by that probe is maximal (XP). When the clitic's features are a subset of the features on the probe, head movement ensues, as predicted by Roberts (2010a). This nicely explained the types of movements involved in standard clitic climbing and ECM constructions.

Furthermore, it was discovered with ECM sentences that due to the order of Case assignment on the higher probe, the embedded DO clitic must be probed first, followed by the embedded subject, which can receive abstract dative Case. Because there is only one dative Case feature allowed by agreeing probe, the embedded object that raises with the subject cannot be an IO. This creates a failure of the Case assigning mechanism, whereby an IO cannot be valued with abstract accusative Case. This also explains why three clitics cannot raise to object—both the embedded subject and the embedded IO would be vying for one available dative Case feature.

Finally, it was shown that other island effects that prevent clitic climbing are readily explained by the Phase Impenetrability Condition. The presence of *wh*-elements and negative clausal operators in the embedded clause signals the presence of phase head C, which is the locus

of +WH and +NEG features in Phase Theory. For these elements to be present in the derivation, there must be a phase head C, rather than a defective C_{DEF}, which ordinarily allows for clitic climbing. The ban on raising to object in these cases is due to the PIC, which renders the clitics in the edge of the lower vP phase invisible to the probing heads in matrix v*P. Phase head C is the cutoff point for the higher verbal probe, and everything below is sent to Transfer. As such, the clitics in these sentences must be licensed *in situ* by the embedded infinitive.

In the next chapter, we will make a few concluding remarks, and reflect on the advantages of the type of approach outlined in these pages for future research on the topic of clitics and head movement within syntactic theory.

CHAPTER 6

Conclusions

In this work we hope to have convincingly demonstrated that the DO and IO clitics of Spanish are DP arguments that move to their derived positions in the syntax. The fact that these clitics are sensitive to general abstract conditions on movement suggests that a syntactic approach to the study of these elements is still well motivated, especially with all of the advances in syntactic theory since the early and pioneering transformational accounts. The principles outlined by Minimality, Case, and Phases, as well as the operation of narrow syntactic head movement, are all needed to explain the restricted placement of argument clitics in most dialects of Spanish. The behavior of clitics in these dialects, as well as those of the standard dialects enumerated upon by *la Real Academia Española*, is best explained by the movement hypothesis, first outlined for Romance clitic pronouns by Kayne (1975) and Quicoli (1976). Despite the growing influence of Base Generation approaches in recent decades, such non-movement hypotheses cannot fully account for island, intervention and Case-assignment effects observed with clitics, including but not limited to the well-known SSC and TSC effects. Although it could be well argued that our approach is assimilable to a sophisticated base generation analysis, such as an updated version of Sportiche (1996, 1999), by replacing the source copy of the clitic with *pro*, we ultimately find movement to be more in line with minimalist assumptions. As a major

desideratum of Minimalism is to dispense with unnecessary empty categories and projections, we opt for movement in part to do away with the postulation of object *pro* in clitic constructions, as well as the creation of separate projections for clitic placement. Furthermore, in Minimalism, there is no empty anaphor category, yet such a category would be needed for base generation of reflexive anaphor clitics, of the type discussed at the end of Chapter 5. A movement analysis of reflexive object clitics avoids the unnecessary creation of yet another empty category.

On the other hand, base generation appears to be a useful approach for understanding dialects of Spanish in which clitics no longer appear to function as pronouns. Base generation accounts are especially appropriate when considering data from dialects like *Andino* Spanish and Los Angeles Vernacular Spanish (LAVS), where Kayne's Generalization does not hold and doubling is permitted across the board. Furthermore, in these latter dialects, there need be no overt agreement between double and clitic, further suggesting separate origins for clitic and double. Non-agreeing object clitics appear to be of a different category than DO and IO clitics in standard Spanish. In conclusion, the movement approach outlined in this work is not intended to invalidate agreement approaches that have usefully explained dialectal variation where clitics are best understood as verbal morphemes.

Nor do the findings of the present work invalidate morphological approaches to the placement of clitics in clusters, such as those offered by Bonet (1991), or much more recently, Cuervo (2013). There are undoubtedly post-syntactic and base-generating mechanisms that explain certain aspects of clustering and the placement of non-argument clitics, such as inherent reflexives and speaker ethical dative clitics discussed by Strozer (1976). What the present work does strongly suggest, however, is that a syntactic explanation is still needed in addition to the

morphological approaches mentioned above, and that many phenomena related to clitic placement cannot be merely reduced to morphological processes. What makes clitics such a fascinating topic of study is the complexity of their distribution, and this is directly related to the fact they are sensitive to the dictates of both syntax and morphology. Another complication that makes clitics worthy of attention is the fact that they are syntactically hybrid elements, needing to move at times as maximal elements (phrases) and at other times as minimal elements (heads). The study of object clitics from a movement perspective allows us to tease apart XP movement from the movement of terminals, and to ascertain the conditions under which each species of movement can possibly take place.

For all of the above reasons, clitics are truly a unique grammatical element, one that needs to be studied from multiple theoretical vantage points. Studies of clitics not only shed light on the nature of movement, but they also provide insights into the workings of the syntax-PF interface in Phase Theory. The approach outlined in this work is intended to inspire renewed interest in the topics of head and clitic movement and to pave the way for future investigation.

Dialectal variation is another fascinating topic for future research, as in depth studies of the use of clitics in many vernacular dialects of Spanish, such as LAVS, have not yet been done, and hold great appeal. Explaining the function and distribution of expletive clitics in Mexican and other dialects of Latin American Spanish should also be on the research agenda for Phase Theorists, in addition for how to account for base-generated clitics, including inherent reflexives and speaker datives, in a principled manner.

We look forward to exploring all of these avenues in the future, as well as making further connections between the morphological and syntactic components of grammar that together completely regulate the behavior of clitics. To the work that lies ahead, we say: ¡Órale!

BIBLIOGRAPHY

- Alvar, Manuel (ed). 1972. *Cuestionario para el estudio coordinado de la norma lingüística culta de las principales ciudades de Iberoamérica y de la Península ibérica II: Morfosintaxis*. Madrid: Consejo Superior de Investigaciones Científicas.
- Anderson, Stephen R. 2005. *Aspects of the Theory of Clitics*. New York: Oxford University Press.
- Anagnostopoulou, Elena. 2003. *The Syntax of Ditransitives: Evidence from Clitics*. Berlin, New York: Mouton de Gruyter.
- Anagnostopoulou, Elena. 2006. Clitic Doubling. In Martin Everaert and Henk van Riemsdijk (eds.) *The Blackwell Companion to Syntax*. Volumes I-V (Volume I, Ch. 14). Blackwell Publishing. 519-580.
- Anagnostopoulou, Elena. 2012. Variation in Clitic Doubling. Minicourse presented at Leiden University, September 5, 2012.
- Baker, Mark C. 1988. *Incorporation: A Theory of Grammatical Function Changing*. Chicago: University of Chicago Press.
- Barss, A. and H. Lasnik. 1986. A note on anaphora and double objects. *Linguistic Inquiry* 17: 347-354.
- Bello, Andrés. 1847. *Gramática de la lengua castellana, destinada al uso de los americanos*. Rpt.:1981. Instituto Universitario de Lingüística Andrés Bello: Cabildo Insular de Tenerife.
- Belletti, Adriana. 1982. Morphological passive and pro-drop: the impersonal construction in Italian. *Journal of Linguistic Research* 2(4): 1-34.
- Bernstein, Judy B. 2008. Reformulating the Determiner Phrase Analysis. *Language and Linguistics Compass* 2/6: 1246-1270.
- Biberauer, Theresa, and Ian Roberts. 2011. Negative words and related expressions: A new perspective on some familiar puzzles. In Pierre Larrivé and Richard P. Ingham (eds.), *The Evolution of Negation: Beyond the Jespersen Cycle*. 23-60.
- Bleam, Tonia M. 2000. *Leísta Spanish and the Syntax of Clitic Doubling*. Ph.D. dissertation, University of Delaware.
- Boas, Frans. 1911. *Handbook of American Indian Languages*, 1. Bureau of American Ethnology, Bulletin 40.

- Bobaljik, Jonathan D. Floating Quantifiers: Handle with care. In Lisa Cheng and Rint Sybesma (eds.) *The Second Glot International State-of-the-Article Book*. Mouton de Gruyter, pp. 107-148.
- Boeckx, Cedric and Norbert Hornstein. 2005. A Gap in the ECM Paradigm. *Linguistic Inquiry*, 36. 437-441.
- Boeckx, Cedric. 2006. *Linguistic Minimalism: Origins, Concepts, Methods, and Aims*. New York: Oxford University Press.
- Boeckx. 2008. *Understanding Minimalist Syntax: Lessons from Locality in Long-Distance Dependencies*. Oxford, UK: Blackwell Publishing.
- Boeckx, Cedric and Ángel J. Gallego. 2008. Clitic Climbing by (Long Distance) Agree. Linguistic Institute in the Old World. Workshop on explanatory proposals of clitics. Universitat Pompeu Fabra, Barcelona, 18-29 August 2008.
- Boeckx, Cedric. 2012. *Syntactic Islands*. Cambridge, UK: Cambridge University Press.
- Bonet, Eulalia M. 1991. Morphology After Syntax: Pronominal Clitics in Romance. PhD dissertation: MIT.
- Borer, Hagit. 1984. *Parametric Syntax: case studies in Semitic and Romance languages*. Dordrecht: Foris.
- Bosque, Ignacio (ed.) 2009. *Nueva gramática de la lengua española*. Madrid: Real Academia Española.
- Bosque, Ignacio, and Javier Gutiérrez-Rexach. 2009. *Fundamentos de sintaxis formal*. Madrid: Ediciones Akal, S.A.
- Burzio, Luigi. 1986. *Italian Syntax: A Government- Binding Approach*. Holland: D. Reidel Publishing Company.
- Cardinaletti, Anna, and Michal Starke. 1999. The typology of structural deficiency: On the three grammatical classes. In Henk van Reimsdijk (ed.) *Clitics in the Languages of Europe*. Berlin: Mouton de Gruyter: 145-233.
- Cardinaletti, Anna, and Uri Shlonsky. 2004. Clitic Positions and Restructuring in Italian. *Linguistic Inquiry* 35: 519-557.
- Carnie, Andrew. 2013. *Syntax: A Generative Introduction*. Third Edition. Oxford, UK: Wiley-Blackwell.

- Cinque, Guglielmo. 2006. *Restructuring and Functional Heads. The Cartography of Syntactic Structures (vol. 4)*. Oxford: Oxford University Press.
- Chomsky, Carol. 1969. *The Acquisition of Syntax in Children from 5 to 10*. Cambridge, MA: MIT Press.
- Chomsky, Noam. 1957. *Syntactic Structures*. The Hague: Mouton.
- Chomsky, Noam. 1973. Conditions on transformations. In Anderson, S. and Kiparsky, P. (eds.) *A Festschrift for Morris Halle*. New York: Holt, Rinehart, and Winston. 232-286.
- Chomsky, Noam. 1986a. *Barriers*. Cambridge, MA: MIT Press.
- Chomsky, Noam. 1986b. *Knowledge of Language: Its nature, origin, and use*. New York: Praeger.
- Chomsky, Noam. 1987. *Language and Problems of Knowledge: The Managua Lectures*. Cambridge, MA: MIT Press.
- Chomsky, Noam. 1993. A minimalist program for linguistic theory. In Hale, Kenneth L. and S. Jay Keyser (eds.) *The view from Building 20: Essays in linguistics in honor of Sylvain Bromberger*, pp. 1-52. Cambridge, MA: MIT Press.
- Chomsky, Noam. 1995a. Bare Phrase Structure. In Gert Webelhuth (ed.) *Government and Binding Theory and the Minimalist Program*. Oxford: Blackwell: 383-439.
- Chomsky, Noam. 1995b. *The Minimalist Program*. Cambridge, Mass.: MIT Press.
- Chomsky, Noam. 2000a. Minimalist Inquiries: The Framework, in Roger Martin, David Michaels, and Juan Uriagereka (eds.) *Step by Step: Essays on Minimalism in Honor of Howard Lasnik*. Cambridge, MA: MIT Press: 89-155.
- Chomsky, Noam. 2001. Derivation by Phase. In M. Kenstowicz (ed.), *Ken Hale: a Life in Language*. Cambridge, MA: MIT Press. 1-52.
- Chomsky, Noam. 2004. Beyond Explanatory Adequacy. In Adriana Belletti (ed.), *Structures and Beyond: The Cartography of Syntactic Structures, Volume 3*. Oxford University Press: 104-131.
- Chomsky, Noam. 2008. On Phases. In Robert Freidin, Carlos Peregrín Otero and Maria Luisa Zubizarreta (eds.), *Foundational Issues in Linguistic Theory. Essays in Honor of Jean-Roger Vergnaud*, pp. 133-166. Cambridge, MA: MIT Press.
- Chomsky, Noam. 2013. Problems of Projection. *Lingua*, 130. 33-49.

- Collins, Chris. 1997. *Local Economy*. Cambridge, MA: MIT Press.
- Cuervo, Rufino José. 1895. Los casos enclíticos y proclíticos del pronombre de tercera persona en castellano. In *Obras: Segunda edición, Tomo III*. Rpt.: 1987. Bogotá: Instituto Caro y Cuervo-Biblioteca Colombiana. 167-239.
- Cuervo, María Cristina. 2003. Datives at Large. Ph.D. dissertation, MIT.
- Cuervo, María Cristina. 2010. Against ditransitivity. *Probus*, 22. 151-180.
- Déchaîne, Rose-Marie., and Martina Wiltschko. 2002. Decomposing pronouns. *Linguistic Inquiry* 33: 409-442.
- Demonte, Violeta. 1995. Dative alternation in Spanish. *Probus* 7: 5-30.
- Dobrovie-Sorin, Carmen. 1998. Impersonal *se* constructions in Romance and the passivization of unergatives. *Linguistic Inquiry* 29 (3). 399-438.
- Emonds, Joseph E. 1971. Root, structure-preserving and local transformations. PhD Dissertation: MIT.
- Emonds, Joseph E. 1976. *A transformation approach to English syntax: Root, structure-preserving and local transformations*. New York: Academic Press.
- Emonds, Joseph E. 1978. The verbal complex V²-V in French. *Linguistic Inquiry* (9): 151-175.
- Emonds, Joseph E. 1999. How clitics license null phrases: A theory of the lexical interface. In Henk van Riemsdijk (ed.) *Clitics in the Languages of Europe*. Berlin: Mouton de Gruyter. 291-367.
- Fabb, Nigel. 1984. *Syntactic Affixation*. Ph.D. dissertation, MIT.
- Fernández-Ordóñez, Inés. 1999. Leísmo, láismo y loísmo. In Ignacio Bosque and Violeta Demonte (eds.), *Gramática descriptiva de la lengua española*. Madrid: Editorial Espasa Calpe: 1317-1397.
- Fernández Soriano, Olga. 1993. Los pronombres átonos en la teoría gramatical: Repaso y balance. In Olga Fernández Soriano (ed.) *Los pronombres átonos*. Buenos Aires: Taurus Universitaria. 13-62.
- Gallego, Ángel J. 2010. *Phase Theory*. Amsterdam: John Benjamins Publishing Company.
- García, Erica C. 2009. *The Motivated Syntax of Arbitrary Signs: Cognitive constraints on Spanish clitic-clustering*. Amsterdam: John Benjamins Publishing Company.

- González-López, Verónica. 2008. Spanish Clitic Climbing. PhD Dissertation: The Pennsylvania State University.
- Gutiérrez-Rexach, Javier. 2001. Interface conditions and the semantics of argument clitics. In Javier Gutiérrez-Rexach and Luis Silva-Villar (eds.) *Current Issues in Spanish Syntax and Semantics*. New York: Mouton de Gruyter. 107-142.
- Haegeman, Liliane. 1992. *Theory and Description in Generative Syntax: A Case Study of West Flemish*. Cambridge, UK: Cambridge University Press.
- Hornstein, Norbert, Jairo Nunes, and Kleanthes K. Grohmann. 2005. *Understanding Minimalism*. Cambridge, UK: Cambridge University Press.
- Huang, James. 1982. Logical relations in Chinese and the theory of grammar. PhD Dissertation: MIT.
- Jaeggli, Osvaldo. 1982. *Topics in Romance Syntax*. Foris: Dordrecht, Netherlands.
- Jaeggli, Osvaldo. 1986b. Three Issues in the Theory of Clitics. In Hagit Borer (ed.) *Syntax and Semantics 19: The Syntax of Pronominal Clitics*. Orlando, Florida: Academic Press. 15-42.
- Kayne, Richard. 1975. *French Syntax: The Transformational Cycle*. Cambridge, MA: MIT Press.
- Kayne, Richard. 1991. Romance clitics, verb movement and PRO. *Linguistic Inquiry* 22: 647-686.
- Kayne, Richard. 1994. *The antisymmetry of syntax*. Cambridge, MA: MIT Press.
- Koizumi, Masatoshi. 1993. Object agreement phrases and the split VP hypothesis. In *Papers on Case and Agreement I: MIT working papers in linguistics* 18, 99-148.
- Koizumi, Masatoshi. 1995. Phrase structure in minimalist syntax. Phd dissertation: MIT.
- Koopman, Hilda. 1984. *The Syntax of verb-movement: From verb movement rules in in the Kru languages to Universal Grammar*. Dordrecht: Foris.
- Laka, Itziar. 1990. Negation in Syntax: On the Nature of Functional Categories and Projections. PhD dissertation: MIT.
- Lasnik, Howard, and Mamoru Saito. *Move α : Conditions on Its Application and Output*. Cambridge, Massachusetts: MIT Press.
- Larson, Richard K. 1988. On the Double Object Construction. *Linguistic Inquiry* 19: 335-391.

- Larson, Richard K. 1990. Double Objects Revisited: Reply to Jackendoff. *Linguistic Inquiry* 21: 589-632.
- Lechner, Winfried. 2005. Interpretive effects of head-movement. Manuscript: University of Tübingen. On Ling Buzz: (ling Buzz/000178).
- Legate, Julie. 2003. Some Interface Properties of the Phase. *Linguistic Inquiry* 34: 506-516.
- Legate, Julie Anne. 2008. Morphological and abstract Case. *Linguistic Inquiry* 39: 55-101.
- Leonetti, Manuel. 2007. Clitics do not encode specificity. In Georg A. Kaiser and Manuel Leonetti (eds.), *Proceedings of the Workshop Definiteness, Specificity and Animacy in Ibero-Romance Languages*. Universidad de Alcalá: 111-140.
- Lipski, John M. 1994. *Latin American Spanish*. London and New York: Longman.
- Longobardi, Giuseppe. 2008. Reference to individuals, person, and the variety of mapping parameters. In Henrik Høeg Müller and Alex Klinge (eds.) *Essays on Nominal Determination: From morphology to discourse management*. Amsterdam: John Benjamins:189-211.
- Luján, Marta and Claudia Parodi. 2001. Clitic-doubling and the acquisition of agreement in Spanish. In Javier Gutiérrez-Rexach and Luis Silva-Villar (eds.) *Current Issues in Spanish Syntax and Semantics*. New York: Mouton de Gruyter. 193-217.
- Luján, Marta. 1993. La subida de clíticos y el modo en los complementos verbales del español. In Olga Fernández Soriano (ed.), *Los pronombres átonos*. Madrid: Taurus Universitaria: 235-284.
- Mann, Daniel. 2012. Chilean Clitic Reduplication: Implications for Morphology and Syntax. *Columbia University Working Papers in TESOL and Applied Linguistics*. Vol. 12, No. 2: 17-37.
- Marantz, Alec. 2013. Verbal argument structure: Events and participants. *Lingua* 130: 152-168.
- Martins, Ana Maria. 2000. A Minimalist Approach to Clitic Climbing. In João Costa (ed.) *Portuguese Syntax: New Comparative Studies*, pp. 169-190. New York: Oxford University Press.
- Marantz, Alec. 2013. Verbal argument structure: Events and participants. *Lingua* 130: 152-168.
- Masullo, Pascual J. 1992. Incorporation and Case Theory in Spanish: A crosslinguistic perspective. PhD Thesis: University of Washington.

- Mateu, Victoria Eugenia. 2014. Object Clitic Omission in Child Spanish: Evaluating Representational and Processing Accounts. *Language Acquisition* 00: 1-45.
- McCawley, J.D. 1971. Tense and time reference in English. In C. Fillmore and D. Langendoen (eds.), *Studies in Linguistic Semantics*. New York: Holt, Rinehart, and Winston. 95-113.
- Mendikoetxea, Amaya. 1992. On the nature of agreement: the syntax of ARB SE in Spanish. PhD Dissertation: University of York.
- Mendikoetxea, Amaya. 2008. Clitic impersonal constructions in Romance: syntactic features and semantic interpretation. In Anna Siewierksa (ed.), *Impersonal constructions in grammatical theory*. Special Issue of the *Transactions of the Philological Society* 106(2). Oxford, UK: Blackwell. 290-336.
- Mendikoetxea, Amaya. 2012. Clitics in Spanish. In José Ignacio Hualde, Antxon Olarrea, and Erin O'Rourke (eds.), *The Handbook of Hispanic Linguistics*. Blackwell Publishing Ltd. 477-502.
- Montalbetti, Mario M. 1984. *After Binding: On the Interpretation of Pronouns*. PhD Dissertation: MIT.
- Moyna, María Irene. 1999. Pronominal clitic stress in Río de la Plata Spanish: an optimality account. *The SECOL Review*, 23. 15-44.
- Narita, Hiroki. 2011. *Phasing in Full Interpretation*. PhD Dissertation: Harvard University.
- Nevis, Joel A., Brian D. Joseph, Dieter Wanner, and Arnold M. Zwicky. 1994. *Clitics: A Comprehensive Bibliography 1892-1991*. Amsterdam: John Benjamins Publishing Company.
- Nunes, Jairo. 2004. *Linearization of Chains and Sideward Movement*. Cambridge, Massachusetts: The MIT Press.
- Ormazabal, Javier and Juan Romero. 2013. Object Clitics, agreement and dialectal variation. *Probus*, 25. 301-344.
- Ordóñez, Francisco. 2012. Clitics in Spanish. José Ignacio Hualde, Antxon Olarrea, and Erin O'Rourke (eds.), *The Handbook of Hispanic Linguistics*. Oxford, U.K.: Blackwell Publishing Ltd. 423- 451.
- Otero, Carlos. 1986. Arbitrary subjects in finite clauses. In Irene Bordelois, Heles Contreras, and Karen Zagana (eds.), *Generative studies in Spanish syntax*. Dordrecht: Foris. 81-110.
- Parodi, Claudia. 1991. *Aspect in the Syntax of Spanish Psych-Verbs*. Ph.D. dissertation, UCLA.

- Parodi, Claudia. 2009a. *El español de Los Ángeles: Koineización y diglosia*. Paper presented at the ALFAL: Cuestiones lingüísticas en relación con la diáspora latinoamericana. Graduate Center, CUNY.
- Parodi, Claudia. 2011. El otro México: Español chicano, koineización y diglosia en Los Ángeles, California. In Rebeca Barriga Villanueva & Pedro Martín Butragueño (Eds.), *Realismo en el análisis de corpus orales: Primer coloquio de cambio y variación lingüística* (pp. 217-243). Mexico, D.F.: El Colegio de México.
- Parodi, Claudia, Kenneth V. Luna, and Ángela Helmer. 2012. El leísmo en América y en España: bifurcación de una norma. *Bulletin of Hispanic Studies*, 89.3: 217-236. Liverpool, UK: Liverpool University Press.
- Penny, Ralph. 2002. *A History of the Spanish Language*. Cambridge, UK: Cambridge University Press.
- Pollock, Jean-Yves. 1989. Verb movement, Universal Grammar and the structure of IP. *Linguistic Inquiry* 20: 365-424.
- Postal, Paul M. 1977. On Raising: One Rule of English Grammar and Its Theoretical Implications. *Language* 53 (3): 621-654.
- Postan, Lawrence. 1953. The Redundant Object Pronoun in Contemporary Spanish. *Hispania* 36: 263-272.
- Pylkkänen, Liina. 2008. *Introducing Arguments*. Cambridge, MA: MIT Press.
- Quicoli, Carlos. 1976. Conditions on clitic movement. *Linguistic Analysis*, 2. 199-224.
- Quicoli, A. Carlos. 1996. Inflection and parametric variation: Portuguese vs. Spanish. In Robert Freidin (ed.), *Current issues in comparative grammar*. Netherlands: Springer. 46-80.
- Quicoli, Carlos. 2008. Anaphora by Phase. *Syntax* 11(3):299-329.
- Radford, Andrew. 2009. *Analysing English Sentences: A Minimalist Approach*. Cambridge, UK: Cambridge University Press.
- Raposo, Eduardo P. and Juan Uriagereka. 2005. Clitic Placement in Western Iberian: A Minimalist View. In Guglielmo Cinque and Richard S. Kayne (eds.) *The Oxford Handbook of Comparative Syntax*. Oxford University Press. 639-697.
- Reuland, Eric. 2001. Primitives of Binding. *Linguistic Inquiry*, 32.3: 439-492.

- Richards, Marc D. 2012. On feature Inheritance, defective phases, and the movement-morphology connection. In Ángel Gallego (ed.) *Phases: Developing the Framework*. Berlin: De Gruyter Mouton. 195-232.
- Richards, Norvin. 2013. Lardil ‘Case Stacking’ and the Timing of Case Assignment. *Syntax* 61:1: 42-76.
- Rizzi, Luigi. 1986. Null objects in Italian and the Theory of *pro*. *Linguistic Inquiry*, 17.3: 501-557.
- Rizzi, Luigi. 1990. *Relativized Minimality*. Cambridge, MA: MIT Press.
- Rizzi, Luigi. 2011. Minimality. In Cedric Boeckx (ed.), *Linguistic Minimalism*. Oxford, UK: Oxford University Press. 220-238.
- Rizzi, Luigi. 2013. Locality. *Lingua*, 130. 169-186.
- Rivas, Alberto Mario. 1977. *A Theory of Clitics*. PhD Dissertation: MIT.
- Rivero, María Luisa. 2002. On impersonal reflexives in Romance and Slavic and semantic variation. In Joaquim Camps and Caroline R. Wiltshire (eds.), *Romance syntax, semantics and L2 acquisition: Selected papers from the Thirtieth Linguistic Symposium on Romance Languages (LSRL)*. Amsterdam: John Benjamins. 169-195.
- Roca, Francesc. 1996. Morfemas objetivos y determinantes: los clíticos del español. *Verba* 23: 83-119.
- Roberts, Ian G.. 1991. Excorporation and minimality. *Linguistic Inquiry* (22): 209-218.
- Roberts, Ian G. 2001. Head movement. In M. Baltin and C. Collins (eds.), *Handbook of syntactic theory*. Oxford, UK: Blackwell. 113-147.
- Roberts, Ian G. 2010a. *Agreement and Head Movement. Clitics, Incorporation, and Defective Goals*. Cambridge, MA: MIT Press.
- Roberts, Ian G. 2010b. A deletion analysis of null subjects. In *Parametric Variation: Null Subjects in Minimalist Theory*. In Biberauer et al. (eds.) Cambridge, UK: Cambridge University Press. 58-86.
- Roberts, Ian G. 2011. Head Movement and the Minimalist Program. In Cedric Boeckx (ed.), *Linguistic Minimalism*. Oxford, UK: Oxford University Press. 195-219.
- Roberts, Ian G. 2012. Phases, head movement and second-position effects. In Ángel Gallego (ed.) *Phases: Developing the Framework*. Berlin: De Gruyter Mouton. 385-440.

- Roldán, Mercedes. 1971. The Double Object Constructions of Spanish. *Language Sciences* 15: 8-14.
- Romero, Juan. 2013. Accusative Datives in Spanish. In Beatriz Fernández and Ricardo Etxepare (eds.) *Variation in Datives: A Microcomparative Perspective*. New York: Oxford University Press: 283-300.
- Rosenbaum, P.S. 1967. *The Grammar of English Predicate Constructions*. Cambridge, MA: MIT Press.
- Ross, John Robert. 1967. *Constraints on Variables in Syntax*. PhD dissertation: MIT.
- Schroten, Jan. 2010. Clitic Doubling in Spanish. Agreement of the third kind. In Martin Everaert, Tom Lentz, Hannah De Mulder, Oystein Nilsen & Arjen Zondervan (eds.) *The Linguistic Enterpraise. From knowledge of language to knowledge in linguistics*. Amsterdam/Philadelphia: John Benjamins. 315–326.
- Silva-Corvalán, Carmen M. 1979. *An Investigation of Phonological and Syntactic Variation in Spoken Chilean Spanish*. Ph.D. dissertation, University of California, Los Angeles.
- Solà, Jaume. 2002. Clitic Climbing and Null Subject Languages. *Catalan Journal of Linguistics* 1: 225-255.
- Sportiche, Dominique. 1988. A theory of floating quantifiers and its corollaries for constituent structure. *Linguistic Inquiry*, 19. 425-451.
- Sportiche, Dominique. 1996. Clitic Constructions. In Johan Rooryck and Laurie Zaring (eds.), *Phrase Structure and the Lexicon*. Netherlands: Springer: 213-276.
- Sportiche, Dominique. 1999. Pronominal clitic dependencies. In Henk van Riemsdijk (ed.) *Clitics in the Languages of Europe*. Berlin: Mouton de Gruyter. 679-708.
- Sportiche, Dominique, Hilda Koopman, and Edward Stabler. 2014. *An Introduction to Syntactic Analysis and Theory*. Oxford, UK: Wiley Blackwell.
- Starke, Michal. 2001. Move dissolves into merge. PhD dissertation: University of Geneva.
- Stowell, Timothy. 1981. *Origins of Phrase Structure*. PhD dissertation: MIT.
- Strozer, Judith R. *Clitics in Spanish*. Ph.D. dissertation: University of California, Los Angeles.
- Suñer, Margarita. 1988. The Role of Agreement in Clitic-Doubled Constructions. *Natural Language and Linguistic Theory* 6. 391-434.

- Suñer, Margarita. 2000. Object-shift: Comparing a Romance language to Germanic. *Probus* 12: 261-289.
- Teomiro, Ismael. 2010. Anaphors at the interfaces. PhD Dissertation: Universidad Autónoma de Madrid.
- Torrego, Esther. 1985. Pronouns and Determiners: A DP Analysis of Spanish Nominals. Manuscript, UMass, Boston.
- Torrego, Esther. 1995. On the Nature of Clitic Doubling. In Héctor Campos and Paula Kempchinsky (eds.) *Evolution and Revolution in Linguistic Theory*. Georgetown University Press. 399-418.
- Travis, Lisa. 1984. Parameters and effects of word order variation. PhD Dissertation: MIT.
- Uriagereka, Juan. 1988. On Government. PhD Dissertation: University of Connecticut.
- Uriagereka, Juan. 1995. Aspects of the syntax of clitic placement in Western Romance. *Linguistic Inquiry*, 26. 79-124.
- Uriagereka, Juan. 2008. Syntactic Anchors: On Semantic Structuring. Cambridge, UK: University Press.
- Vicente, Luis. 2006. Towards a unified theory of movement: An argument from Spanish clefts. In M. Salzmann and L. Vicente (eds.), *Leiden Papers in Linguistics* 2 (3): 46-67.
- Vicente, Luis. 2007. *The Syntax of Heads and Phrases: A Study of Verb (Phrase) Fronting*. PhD Dissertation: Leiden.
- Wanner, Dieter. 1987. *The Development of Romance Clitic Pronouns. From Latin to Old Romance*. Amsterdam: Mouton de Gruyter.
- Zagona, Karen. *The Syntax of Spanish*. Cambridge, MA: Cambridge University Press.
- Zdrojewski, Pablo. 2008. *Por quién doblan los clíticos*. Master's Thesis, Universidad Nacional del Comahue.
- Zwicky, Arnold. 1977. *On clitics*. Bloomington, IN: Indiana University Linguistics Club.
- Zwicky, Arnold, and Geoffrey Pullum. 1983. Cliticization vs. Inflection: English N'T. *Language*, 59. 502-513.