

UC Irvine

SSOE Research Symposium Dean's Awards

Title

HyperXite 9

Permalink

<https://escholarship.org/uc/item/532817sx>

Authors

Antony, Jacob

Chin, Anthony

Whaley, Christopher

et al.

Publication Date

2024-03-15

Copyright Information

This work is made available under the terms of a Creative Commons Attribution License, available at

<https://creativecommons.org/licenses/by/4.0/>

Peer reviewed



Faculty Advisor: Professor Roger Rangel, Professor Sherif Hassaan Special Advisement: Professor David Copp, Professor Dave Dimas, Professor Keyue Smedley, Professor Mark Walter
Team Members: Jacob Antony, Anthony Chin, Allen Hsing, Christopher Whaley, Kaitlyn Nguyen, Marc Haddad, Ryan Mawlawi, Crew Parker, Dillon Kim, Rachael Koo, Daniel Pena, Harbour Li, Jefferson Ng, Aaron Eslava, Brigitte Chung, Max Stark, Angelina Licos, Calvin Kang, Ryan Quach, Andrew Tragger, Angel Diaz, Brian Chau, Riya Goja, Rye Scholin, Taesung Hwang, Sam Der, Syona Mehra, Vrushang Anand, Joshua Nguyen, Nicol Velaya, Timothy Ngo **Interns:** Kaydi Nomura, Oscar Ning, Michelle Ko, Diego Solorzano

Overview

U.S. transportation sector, which includes cars, trucks, planes, trains, and boats, emits 1.9 billion tons of CO2 annually [1]. The Hyperloop is a clean and sustainable alternative form of transportation, relying solely on electric power while being able to travel up to 670 MPH, about 3 times the speed of a high-speed passenger train. Established in 2015 at the University of California Irvine, HyperXite is a team of undergraduate students endeavoring to build a small-scale Hyperloop pod.

Safety Features

- Fail-safe braking mechanisms
 - Mechanical redundancy for rapid pressure loss or power loss
 - Relief valves protect components from over-pressurization
 - Implementation of LIDAR system as final stopping measure
- Protective Circuitry
 - Pre-Charge
 - Manual Isolation Disconnect (MID)
 - Reverse polarity and over-voltage
- Real-time state feedback
 - Pressure depletion tracking
 - High voltage battery monitoring

Cost

Static Structures	\$7,418.99
Braking	\$3,151.34
Dynamic Systems	\$802.03
Propulsion	\$7,167.74
Thermal Cooling	\$323.25
Power Systems	\$4,571.96
Control Systems	\$958.72
Total cost \$24,394.03	

Mechanical Subsystems

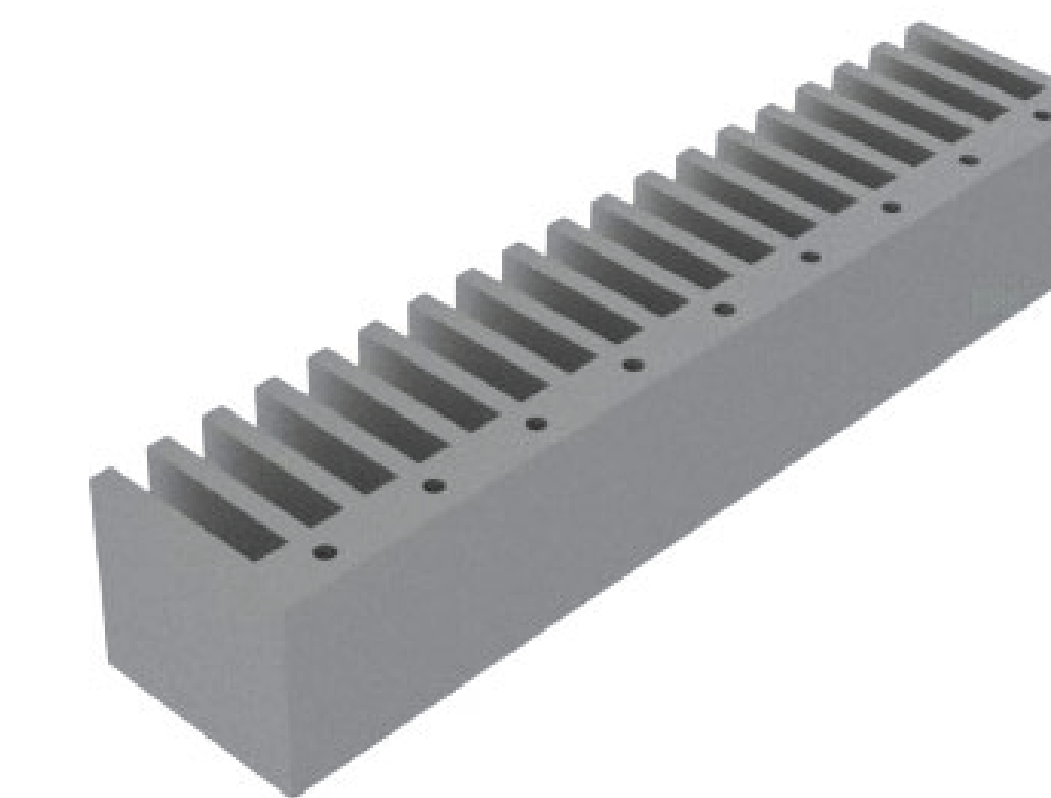

Propulsion and Thermal Cooling

Two Linear Induction motors provide 1250 N of combined thrust to propel the approximately 300 kg pod up to 20 m/s over a 200 ft distance. The thermal Cooling subteam will provide temperature control using an array of 4 fans to keep the maximum temperature of the coil at 160 F.

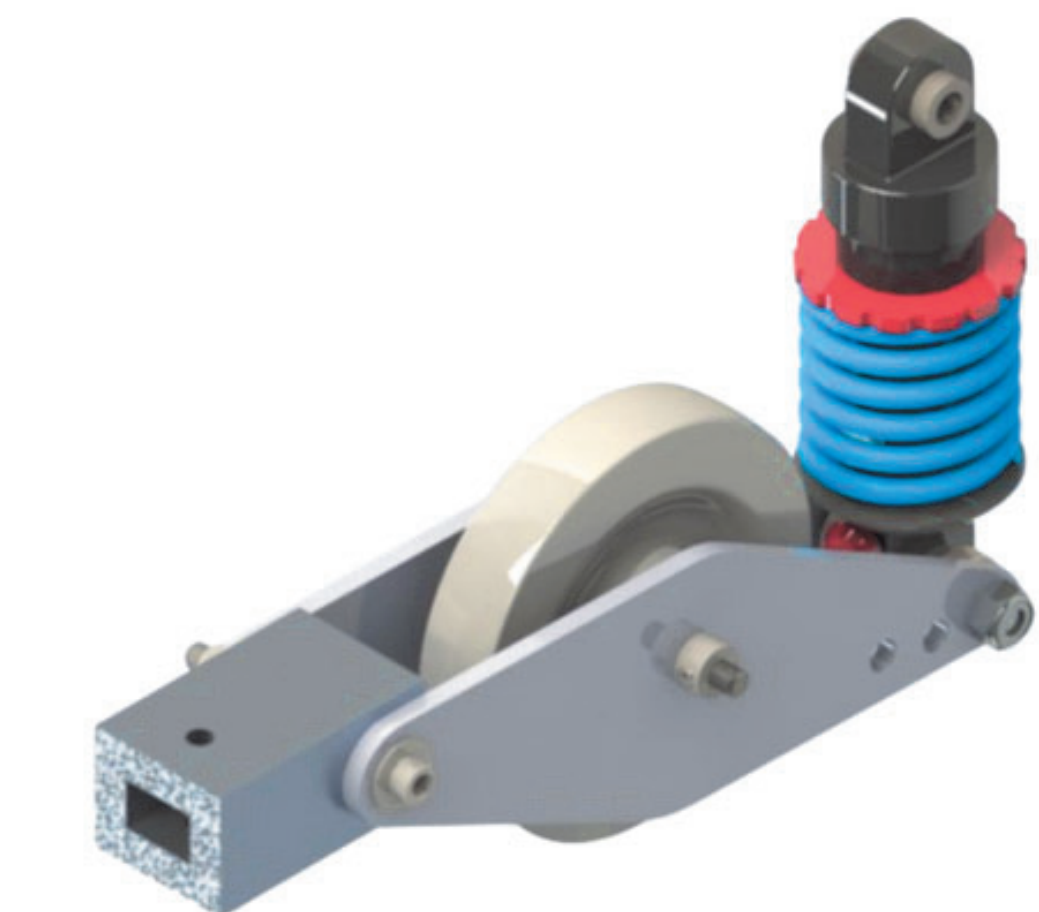

Dynamics

The stabilization system is composed of 8 components. These components work in tandem to provide a lateral and vertical settling time of 0.47 seconds in response to a 1 cm disturbance.

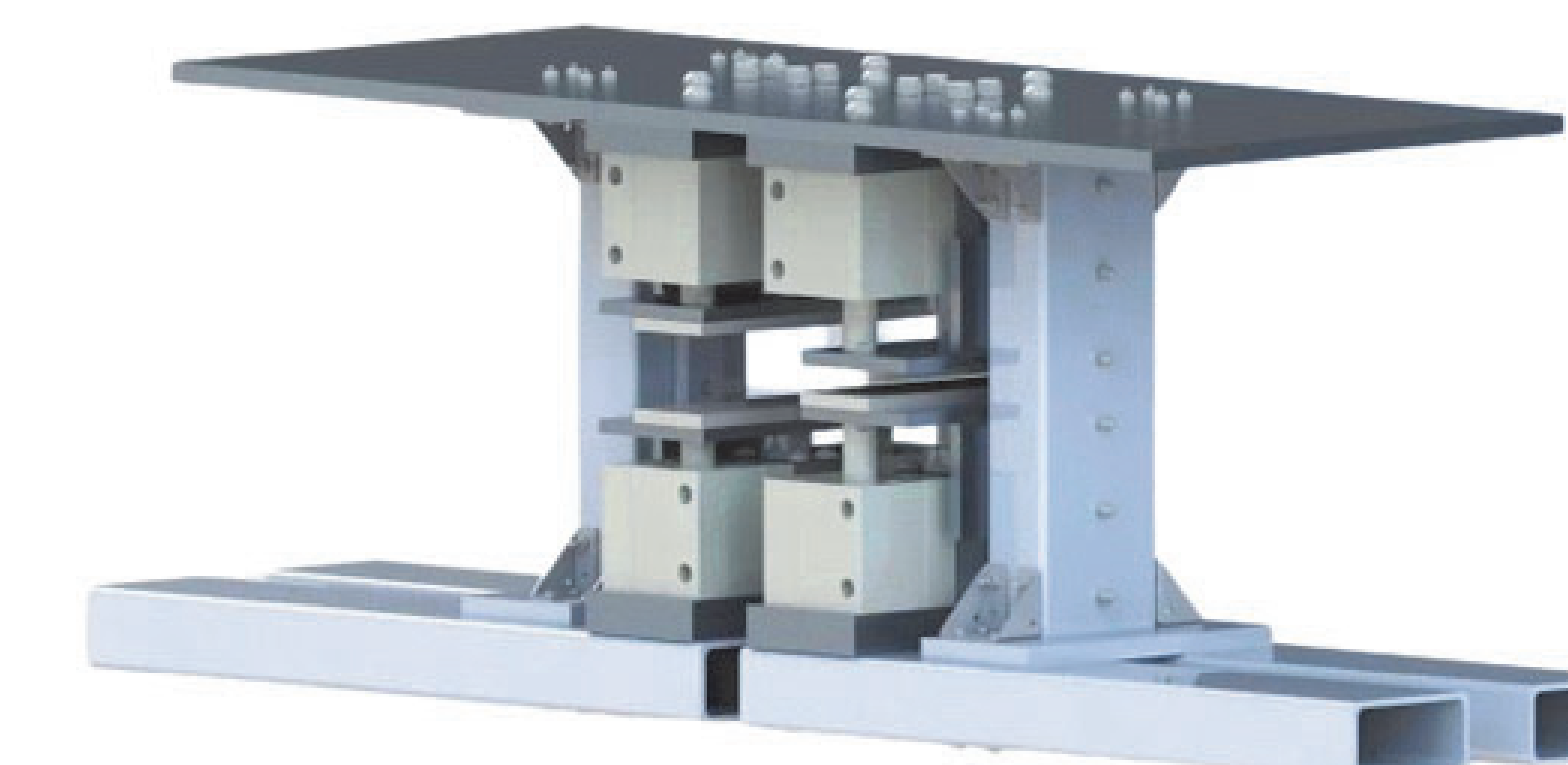

Braking and Pneumatics

Gas springs enable the brakes to be fail-safe. Pneumatic actuators keep the gas springs compressed and the brakes disengaged. To stop the pod, pressurized air is no longer supplied to the actuators, allowing for the gas springs to extend.

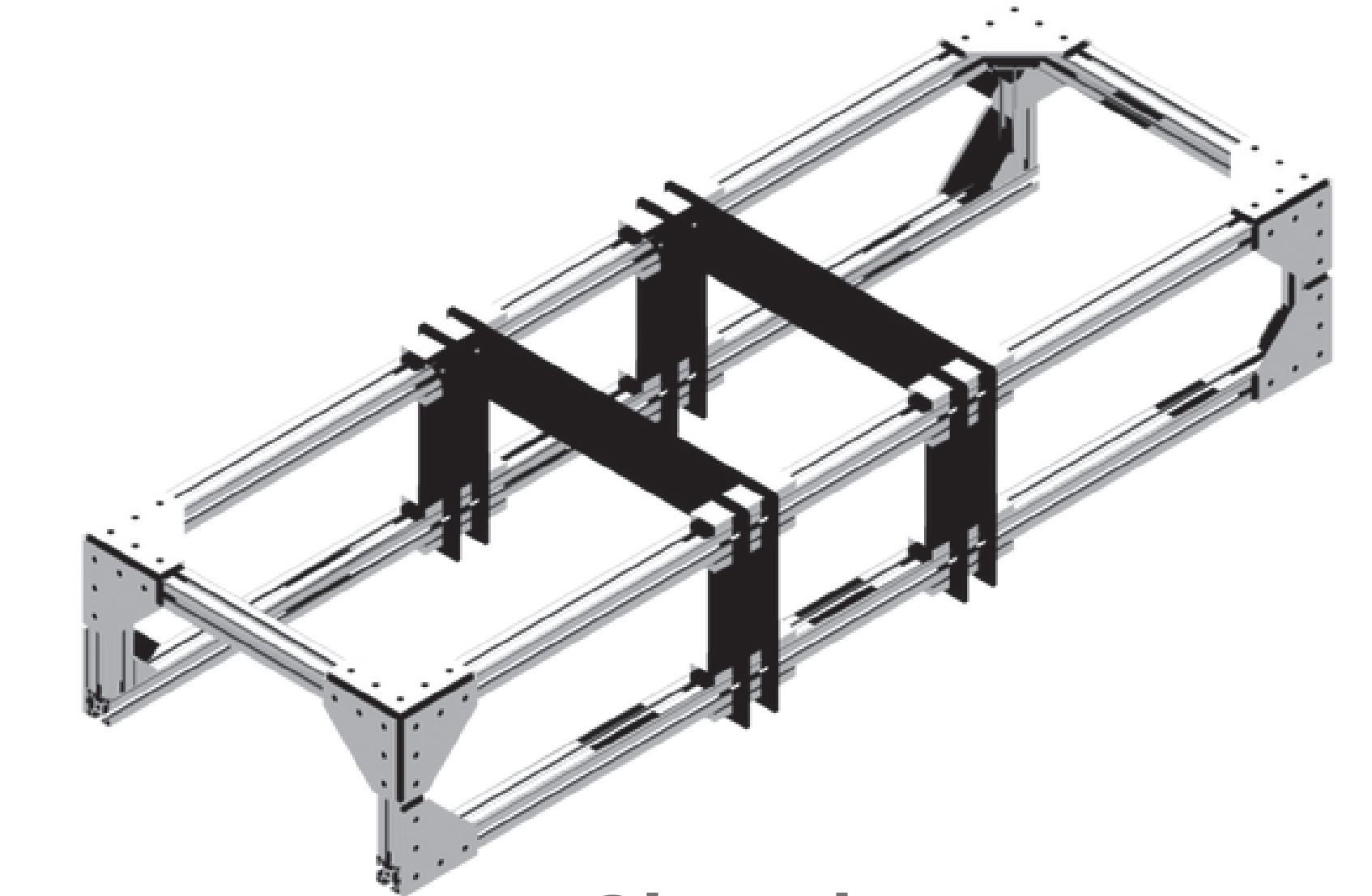

Chassis

The Chassis team utilizes 2 carbon fiber plates to provide stiffness and strength to the chasis. Additionally 8020 framing extrusions is used to provide modularity and easy integration with the other subsystems.

Power Systems

- High Voltage, 44V LiPo pack, for motors
- Low Voltage, 24V pack, for peripherals

Pneumatics

Provides actuation for engagement of the friction braking system

Battery Management System

Intelligent monitoring of current draw, state of charge, voltage per battery cell, and battery temperature

Three-Axis Stabilization

Dampens perturbations from track misalignments to mitigate derailment risk

Chassis

Optimizes modularity for component replacement and structural integrity

Control Systems

Ubiquiti Rockets support speeds up to 150 Mps of real-time TCP/IP communication, for low-latency, high fidelity telemetry transfer

Propulsion

Uses Linear Induction Motors to propel the pod without the need on any downforce required by traditional wheel based propulsion systems.

Braking

Leverages redundant gas springs to deliver 6000 N of instantaneous brake force, even in the event of power loss or pneumatic subsystem failure

Thermal Cooling

Uses an array of 4 fans to manage the thermal losses of the motor.

Electrical Subsystems

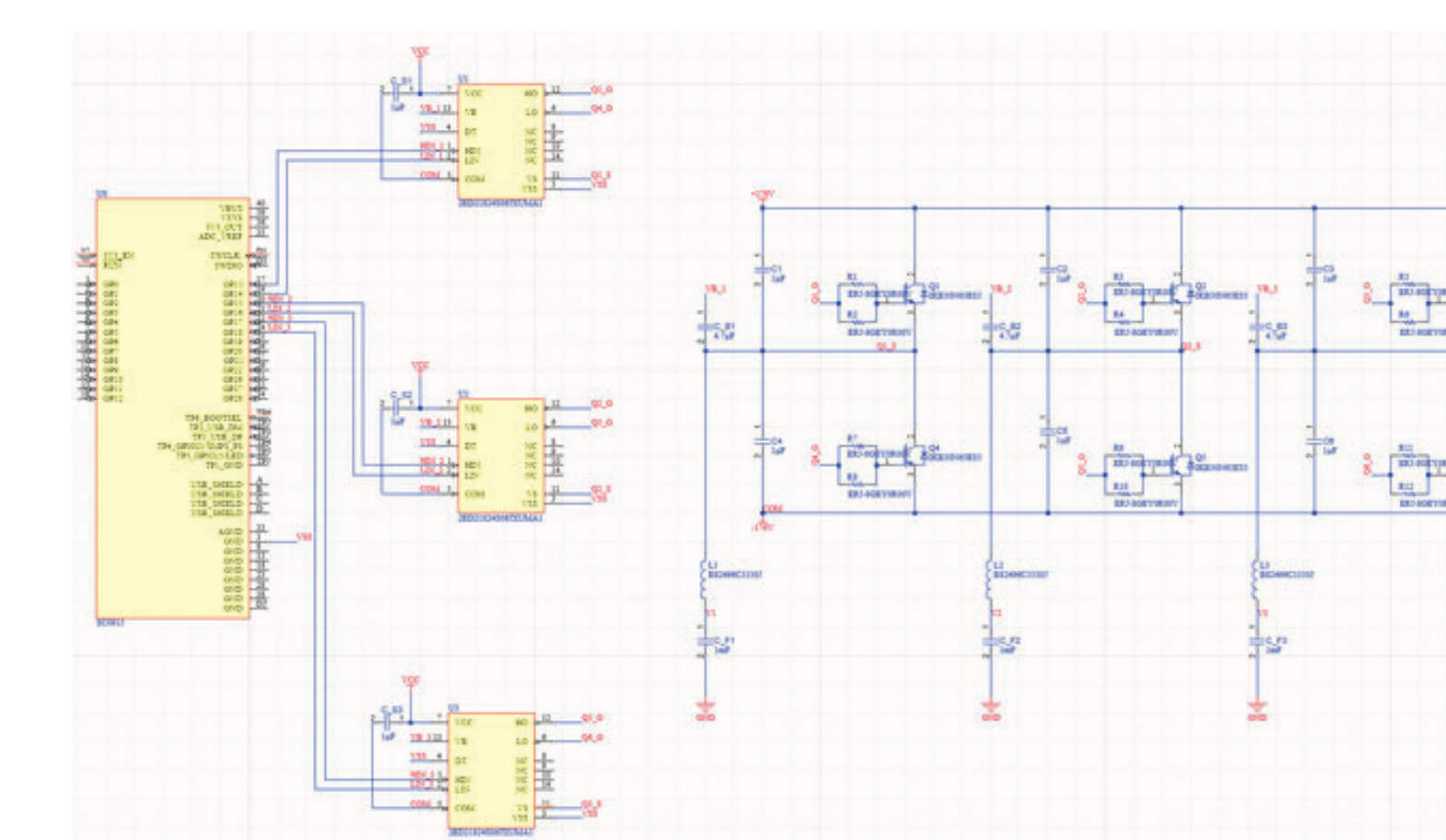

Power Systems

Our Variable Frequency Drive (VFD) is capable of generating sine waves of +/- 176V, 20A RMS of any frequency within the range of 0-37Hz. In addition, Powers has designed and developed additional PCBs, such as: a buck converter, battery management system interface board and control board.

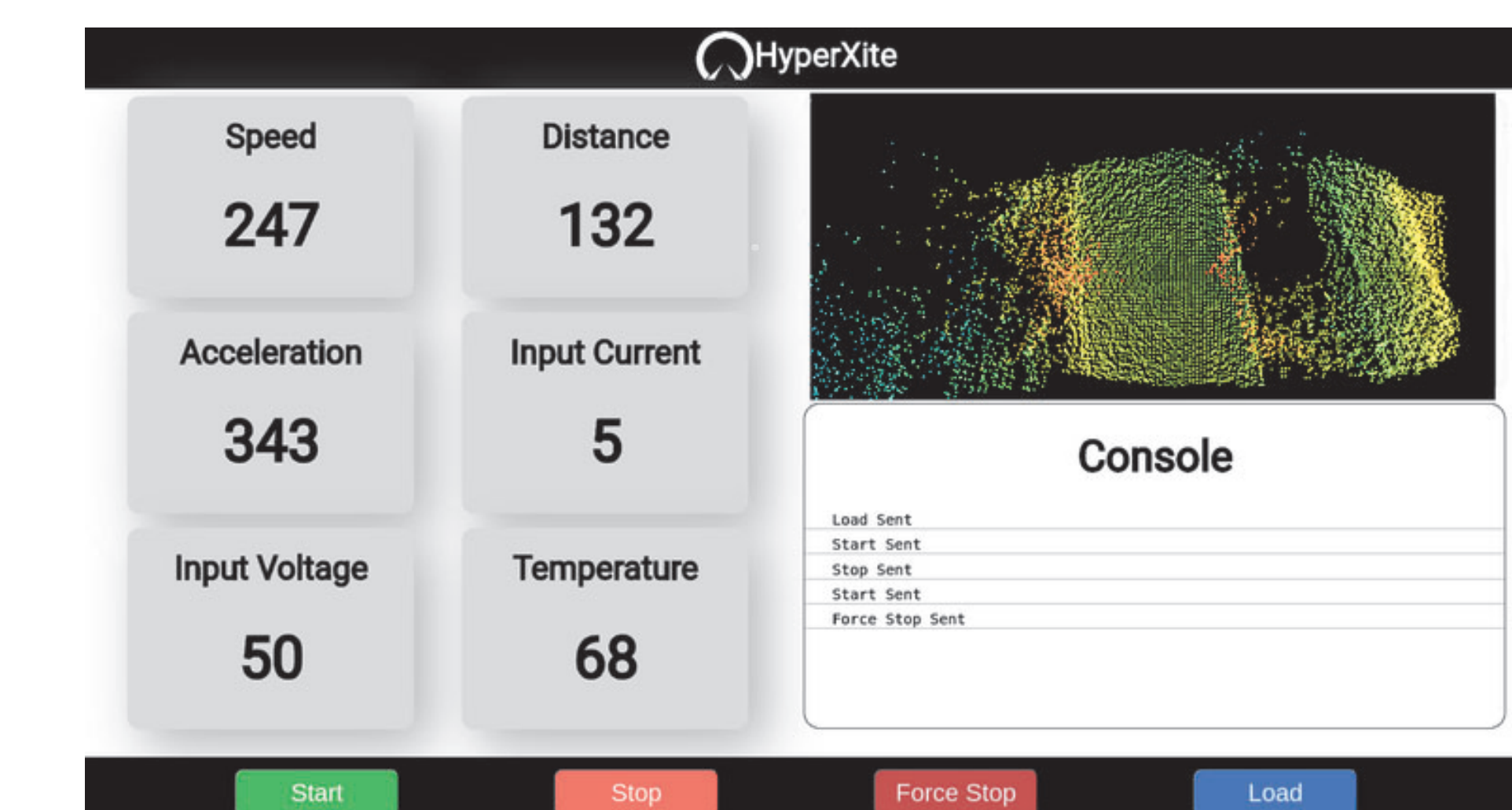

Control Systems

Control Systems has developed a graphical user interface to work in conjunction with the finite state machine to monitor various sensor readings and control the operating state of the pod. Some of the featured sensors are a rotary encoder, LiDAR camera and Rogowski coil.

Acknowledgements

Professor Roger Rangel and Professor Sherif Hassaan: Without your incredible support and guidance, this team would not be where it is today.



Sponsors

References

[1] "Transportation Replaces Power in U.S. as Top Source of CO2 Emissions", Yale Environment 360, <https://e360.yale.edu/digest/transportation-replaces-power-in-u-s-as-top-source-of-co2-emissions>