

Lawrence Berkeley National Laboratory

Lawrence Berkeley National Laboratory

Title

HALF YEAR REPORT ON THE LAWRENCE BERKELEY LABORATORY HEAVY ION FUSION PROGRAM

Permalink

<https://escholarship.org/uc/item/4t08f627>

Author

Authors, Various

Publication Date

1978-03-01

117
6-19-78

14. 174

LBL-7591
UC-20
TID-4500-R66

MASTER

HALF YEAR REPORT ON THE
LAWRENCE BERKELEY LABORATORY
HEAVY ION FUSION PROGRAM

Heavy Ion Fusion Staff

March 31, 1978

Prepared for the U. S. Department of Energy
under Contract W-7405-ENG-48



LBL-7591

ANNUAL REPORT
of the
LAWRENCE BERKELEY LABORATORY
RESEARCH PROGRAM

October 11, 1978 - March 31, 1979

1979

1979

* Work supported by Division of Laser Fusion and Division of Physical Research, US-DOE

I. Conceptual and System Studies:

Because of the urgency of establishing for national planning purposes approximate costs for a variety of heavy ion accelerator systems, there has been an intensive effort to develop conceptual designs and engineering cost information. The most urgent cost requirements are considered to be for a 100 TW, 1 MJ pilot power-plant driver, a scaled-down version in the 0.1 MJ region to serve as the intermediate demonstration experiment (HIDE), and finally for a multi-megajoule test facility. Quite detailed unit costs on rf linacs and sources have been developed and are incorporated in the BNL workshop report. These data are applicable to a full-energy rf linac system or to the injector to a synchrotron or low energy accumulator ring.

Our major efforts have been addressed to systems based upon the induction linac where the scaling of physical size from existing machines to a driver-sized device is over a much larger range than for other accelerator schemes. Consequently, considerable attention must be paid to cost benefits that can occur from large-scale procurements or from mass-production techniques.

Several designs are being pursued which range over the following combinations of strategies and parameters (See Table I):

- i) Injector: (a) Pulsed drift tube type (10 to \approx 100 MeV)
or (b) Rf linac + low energy (500 - 2000 MeV)
accumulator ring
- ii) Ion species: "Uranium" $q = 1$
"Uranium" $q = 4$

iii) Accelerator Column Voltage $\approx 5 - 10$ GV

iv) Number of final beams on target = 2, 4, 8.

The basic data for the high-current transport system throughout (assumed superconducting to save on power) are now considered to be on rather firm footing. Data are being generated for the electric acceleration cavities, but their design and the modulator design depend sensitively on the assumptions made on material types, electrical properties, and costs, and this information can still be at best called tentative at this stage. Also, the optimization of the early stages of the accelerator just after injection is strongly dependent on which design scenario (i.e., choices among i - iv above) is chosen, and so continues to be less than transparent.

Specific tasks addressed during the period in question include:

1. A first cut cost-estimate of a $A = 238$ ⁴⁺, 156 TW, 1MJ, 155 μ C Reference Induction Linac (So-called "pilot-plant"). The repetition rate is 1 pulse per second. This estimate was developed from a number of detailed cost estimates for different example sections of the accelerator. (See Figure 1) These include:
 - 0 - 40 MV Drift tube and induction linac injector combination. Emphasis here was placed on the superconducting solenoid system for the pulse drift tubes and on the 43 and 20 μ sec pulse duration iron-core induction modules. See Figures 2 and 3.
 - Iron-core induction module sections with pulse durations of 2, 1, and 0.5 μ sec., respectively.
 - Ferrite-core induction modules with 200 and 100 nsec pulse duration, respectively, (See Figure 4).
 - Beam-transport systems with superconducting quadrupole elements which have full-aperture fields less than 4 Teslas.

Where possible, costs were based on known construction costs or on estimated costs for projects that are funded already.

2. An examination of power consumption and the effect of repetition rate on cost in going from 1 pps to 10 pps for this example induction linac.
3. A rough cost for a $A = 238^{4+}$, 100 TW, 1MJ, 192 μC and a $A = 238^{1+}$, 100 kJ, 31 μC induction accelerators, i.e., scaling away from the Reference Example.
4. A cost for an rf linac - accumulator system ranging from 500 MeV to 2 GeV, that might act as an injector into an induction linac.
5. A compilation of conventional facility cost data based primarily on PEP experience. PEP is a 2.2 km accelerator structure currently under construction.

The results for exercise (1) above are shown in Figure 1 and should be treated with caution as it is known that the physics design is not an optimum and that the engineering trade-offs have also not been optimized. In fact, in attempting exercises (2) and (3) which involve scaling significantly away from the Reference example we came to appreciate how formidable the scaling problem was. This arises because the engineering solutions (two) for packaging the magnets and cores, the choices of ferromagnetic material (four), the magnet types (two), and the constraints set by magnetic field strength, insulator gradient and longitudinal space-charge--all of which determine how the accelerator is sectionalized (See Figure 1 for example)--vary a lot in importance as a variety of cases with different charge-states or beam charge (microcoulombs) are studied. A start has been made on a computer program to sort through the multi-parametric options and guide us to a correct cost trade-off between beam charge and kinetic energy.

II. Theory

The theoretical effort during this period has been devoted to the following subjects:

a) Stability of Beam Transport

Having examined the properties of the K-V distribution in considerable detail analytically, we have begun to explore the use of computer simulation codes to study more realistic situations. We are testing two codes, one an extension of Herrmannsfeldt's EGUN code and the other similar to the one recently written by Penner. In addition, we explored the possibility with Haber of using the NRL codes, either by remote connection or by acquiring a CDC7600 version to use locally. We now have the capability of remotely retrieving information from his runs for detailed analysis here but are not yet able to initiate runs of our own choice directly from Berkeley.

A semi-analytic procedure has been developed to investigate the extent to which a small spread of betatron frequencies might suppress the instabilities we have found for the K-V distribution. A computer code for solving the resulting equations is being tested.

b) Longitudinal Bunching

The code for solving the appropriate one-dimensional Vlasov equation developed by Neil and Cooper is now in satisfactory operating condition and we have begun to run cases relevant to the HIDE experiment. Particular emphasis is being given to the use of induction cavities to compress and shape bunches.

c) Final Focusing

We have developed parameters for final focusing doublets using HIDE parameters. In examining the effect of momentum spread on focusing, we find a somewhat greater sensitivity than that given by the simple formula in current use. Since many scenarios are severely restricted by even the simplified condition, we have begun to explore the suggestions of Brown and Halbach for achromatic focusing systems.

Our work on this subject has been extended to include triplets as well as doublets, resulting in substantially more attractive solutions in the range of HIDE parameters. We have also looked into the effect of geometric aberrations (corrections to the paraxial ray approximation) and the quadrupole fringing fields and find that it is difficult to hit a 1 mm radius target at a distance of several meters unless the beam emittance is quite small. The addition of an octupole component to the lens fields provides some improvement, but not much. This result, together with the greater sensitivity to momentum spread than previously supposed, may have considerable impact on proposed accelerator schemes.

d) Accelerator Studies

We have assisted in providing parameters for an induction linac for HIDE. Since the front end is the most difficult portion in principle, requiring large currents at low energy, we have explored the alternative possibility of using an r.f. linac and accumulating system to obtain the charge and pulse length appropriate for injection into the induction linac.

III. Large Aperture High Current Cs⁺¹ Ion Source Development

Design and construction of a one-ampere five-hundred-kilovolt Cs⁺¹ ion source is well under way. Cs⁺¹ ions will be formed by contact ionization on a hot iridium-coated plate and accelerated to 500 keV energy in a single accelerating gap. The accelerating voltage is supplied by a 500 kilovolt Marx generator.

A prototype 500 kilovolt Marx generator has been assembled and tested to full voltage at pulse lengths arbitrarily variable from 1 to 10 μ sec. Fabrication and assembly of the ion source is underway.

The oil recirculation system and controls, and the vacuum control system have been installed. The high-voltage isolation transformer for the hot plate has been ordered and all of the parts for the ion source are either being fabricated or have been delivered.

An ion source test system has been operated extensively to provide operating experience and design information for the large ion source. The test system utilizes a 7-inch diameter iridium hot plate and a Marx generator to apply voltage variable from 100 - 200 kV to the gap. Cesium vapor is beamed continuously onto the hot plate at a controllable rate while the pulsed accelerating voltage is applied at a slow repetition rate (5 - 10 per minute). (See Figure 5).

This system has been operated at voltage gradients up to 20 kilovolts per cm in the gap and at apparent ion currents up to 900 mA. This is in reasonable agreement with calculations. The observed current density follows a $v^{3/2}$ relationship over a considerable range which verifies that the current is indeed space charge limited. (See Figure 6).

A grid of three-mil tungsten wires was installed in the gap to simulate the geometry of the large source which will use a grid at the entrance of

the first drift tube. This arrangement was tested at 200 kV up to current densities in excess of 4 mA/cm^2 without encountering sparking difficulties. We were relieved to find that there appears to be no difficulty in holding voltage in spite of the presence of the cesium vapor. This is largely because the presence of the large hot plate maintains the anode and anode grid at a temperature of $> 200^\circ \text{ C}$ relative to the cold chambers walls. A high-speed oil diffusion pump with a liquid nitrogen baffle maintains the ambient operating pressure at $2 - 5 \times 10^{-6}$ Torr. We have abandoned use of an existing low-volume puff-valve; a fast-acting large-aperture puff-valve is under design and will be incorporated into the test system in the near future.

Our experience with this system has given us considerable confidence in the design of the large ion source.

IV. Multi-Aperture Source Development ("Conventional" Source for rf linac)

Development of a multi-aperture Xe plasma arc source of the MATS type has proceeded well. The test stand set-up is shown in Figure 7 and consists of a cup and beam-transformer to monitor the beam about 10 cm from the source, a set of quadrupole lenses to transport the beam to a second cup a meter downstream, and a bending magnet to analyze the charge-state. Apart from some early tests, experiments have been carried out with varying numbers of apertures each 4 mm in diameter and contoured similarly to those used by Osher at LLL. While the source current increases as more apertures are used, so also does the gas-load from the source and this can be destructive to the beam. Frequent changes to the pumping system have been needed to handle the different gas-loads. A small amount of gas is necessary to provide neutralization in the early part of the transport. (Computer calculations on beam transmission indicate about 97% neutralization in the quadrupoles).

Best performance to date has been with 13 apertures and a transported current of 35 mA was obtained. Lack of focussing in the final analyzing section leads to poor transmission (~ 5 mA) into the final cup. Measurements on this sample of the beam show that it is composed of more than 90% charge state +1.

The immediate goal was to obtain 20-30 mA of assured Xe^{+1} ions before moving the source to the Cockcroft-Walton column for further beam acceleration studies, and this seems to have been achieved.

V. General

The high-current large-aperture cesium source test set-up and final source activities are centered in the high-bay accelerator research Building 58A. Installation for an oil-recycling and a separate emergency oil-dump system is complete. Provision of a.c. power adequate to power a long sequence of quadrupoles for the cesium beam propagation experiment is also complete.

The long-standing plan to extend the high-bay area of Building 58A, which will allow expansion of HIF activities in that area, now seems to be close to fruition. The extension is included in the General Plant Projects at LBL in this Fiscal Year and, given no undue delays, construction should begin in early Summer.

Table and Figure Captions

Table I: Example Parameters for Induction Linac for a Pilot Plant with
 $P = 100 \text{ TW}$, $Q = 1 \text{ MJ}$, $\bar{\tau} = 10 \text{ ns}$.

The basic input assumptions and limitations were: the transmittable beam power of the final beam transport system, an assumed emittance ($\epsilon_n = 20$ micrometers) and a target size of 1 mm radius which is the minimum size permitted by the target designers. (More recent work suggests that a different set of requirements set by the final focus conditions would be more appropriate; the general range of parameters is not, however, greatly changed).

Figures

Figure 1: Tentative cost figures for a Reference Example Induction Linac.

The parameters and breakdown in sections are shown in the figure and the cost basis described in the text. The physics design is not optimized and the engineering estimate for the chosen physics design also has not been optimized.

Figure 2: Example pulsed drift-tube injector for the stripping and early section of a pure-pulse power induction linac system.

Figure 3: Induction module sketch based on wound core of iron sheet at the section of the linac requiring the longest pulse.

Figure 4: Induction linac module employing ferrite where the pulse-length is 100 nsec. (a little over half-way down the accelerator).

Figure 5: Schematic of preliminary large Cs^{+1} contact-ionization test source.

Figure 6: Some sample results from the set-up shown in Figure 5 indicating reasonable agreement with expectations for space-charge limited ion current.

Figure 7: The existing 20 keV conventional source test stand in which the goal of $\geq 30 \text{ mA}$ of Xe^{+1} has been achieved.

Table 1: Example Parameters for Induction Linac 1 MJ 100 TW

Ion Species: Uranium			Normalized Emittance $\epsilon_N \equiv 2 \times 10^{-5} \text{ rad-m.}^{(*)}$					$r_t = 1 \text{ mm}$			
Charge State	No. of Final Beams	Final Kinetic Energy ^(a)	Final Voltage	Beam Charge	Final Current per Beam	Final ^(b) Emittance per beam	Range in Lead (R)	Specific ^(c) Energy (w)	f number ^(d) (r = 1 mm)	Nominal Injector Voltage	Final Speed
q	N_f	T_f (GeV)	V_f (GV)	$[I\tau]$ (μC)	I_f (kA)	ϵ/beam (10^5 rad-m)	g-cm^{-2}	MJ/gm	V_{inj} (2 μsec) MV B = 4, $\eta = 0.5$	β	
1	2	11.2	11.2	89	5	5.22	0.25	64	19	45	.306
1	4	7.7	7.7	130	3.3	5.3	0.16	99	19	70	.257
1	8	5.4	5.4	185	2.3	5.35	0.11	145	19	110	.217
4	2	30	7.5	133	7	3.13	0.93	17	32	33	.434
4	4	21	5.2	192	5	3.17	0.57	28	32	50	.407
4	8	14.4	3.6	278	3.5	3.24	0.36	44	31	75	.344

(*) Assumption is false: probably scaling is as $[I\tau]^{1/2}$

(a) Determined from power limit to beams at target: Laslett $f \cdot 0 \cdot m = .71$ for $\eta = 50\%$

(b) Assume for splitting to N_f beams: $\epsilon/\text{beam} = \frac{\epsilon}{(N_f)^{1/4}}$

(c) w taken to be $w = \frac{1}{2\pi \times 10^{-2} \times R} \text{ MJ/gm}$

(d) f-number defined as $\frac{\text{standoff distance}}{\text{Lens diameter}}$. No allowance for space charge [i.e., neutralization assumed] or momentum spread.

TENTATIVE COST FIGURES FOR EXAMPLE INDUCTION LINAC

26 GeV, U^{+4} , 1MJ, 156TW (4 beams), $t_A = 2 \times 10^{-9}$ radian-meters $B_{pole tip} = 4T$.

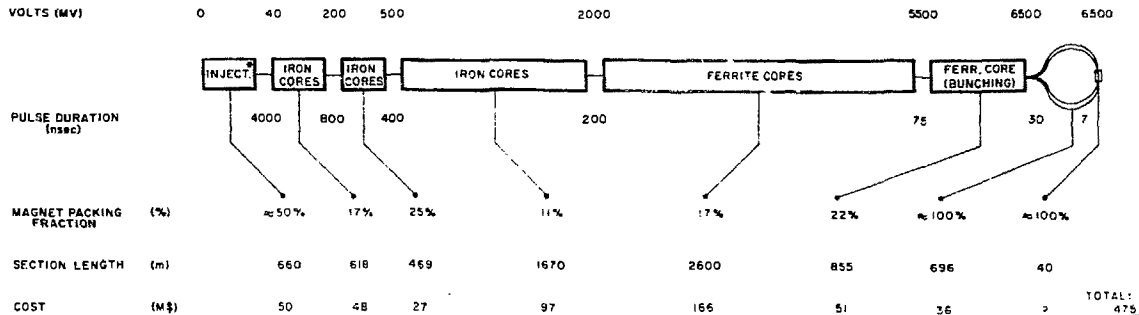

* U^{+4} SOURCE - HELIUM STRIPPER,
 U^{+4} PULSED DRIFT TUBE - INDUCTION LINAC INJECTOR

Figure 1

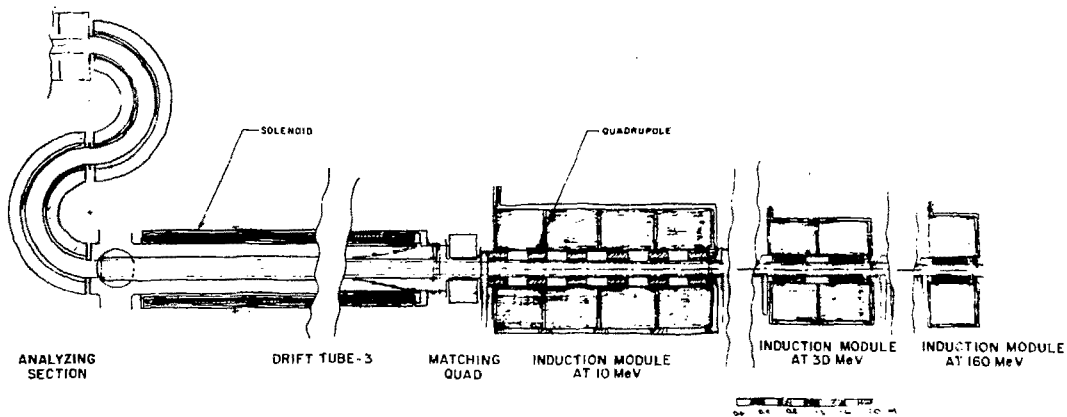
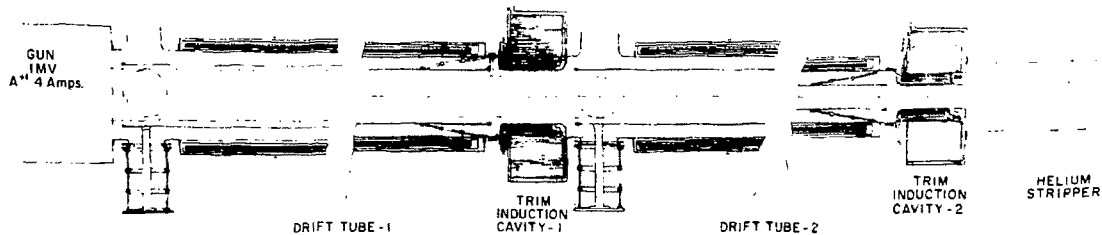

160 MeV, A⁴⁺ (A > 200) INJECTOR
FOR IMJ, 156TW, 155 μ C

Figure 2

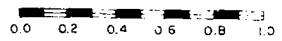
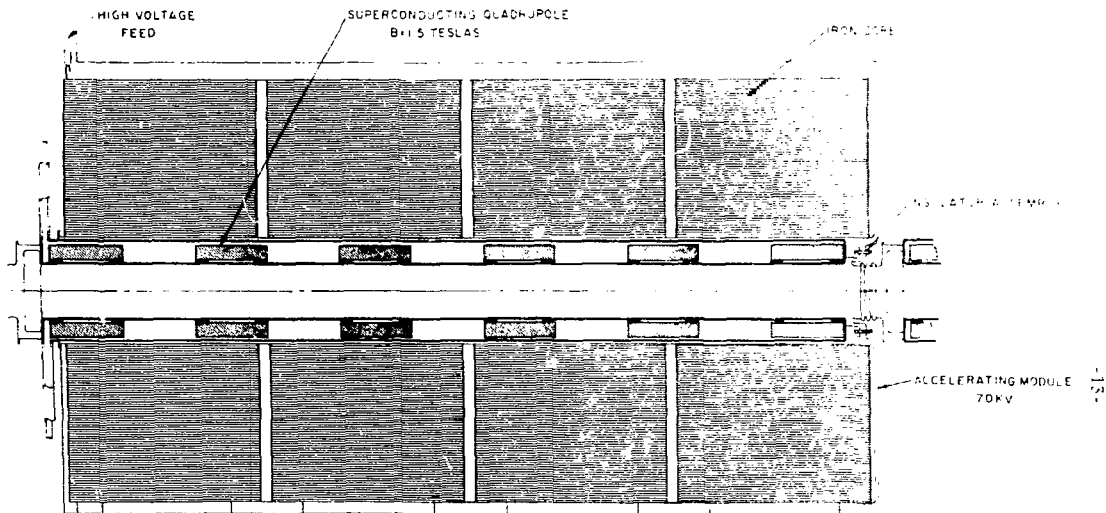

INDUCTION MODULE
 $A=238^{4+}$, 10 MeV, 4 Amp., 43 μ sec

Figure 3

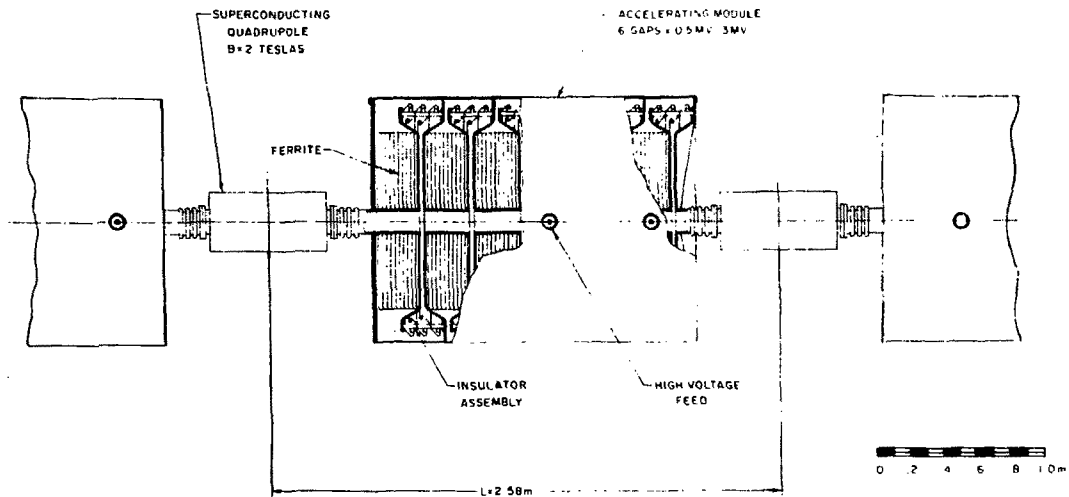
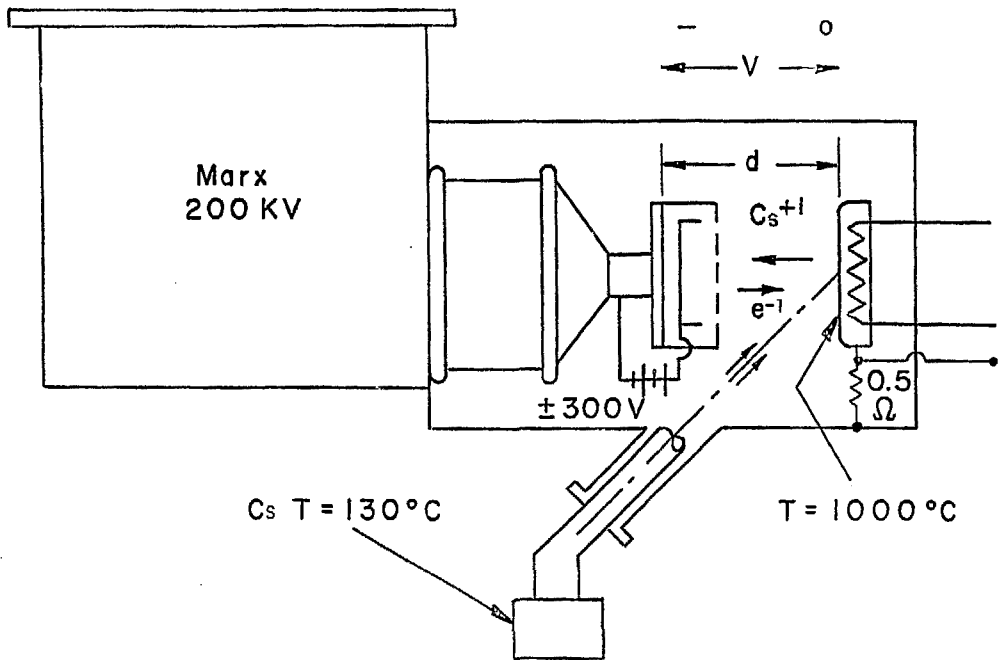

Figure 4



Cs Test Set-up 1977

Figure 5

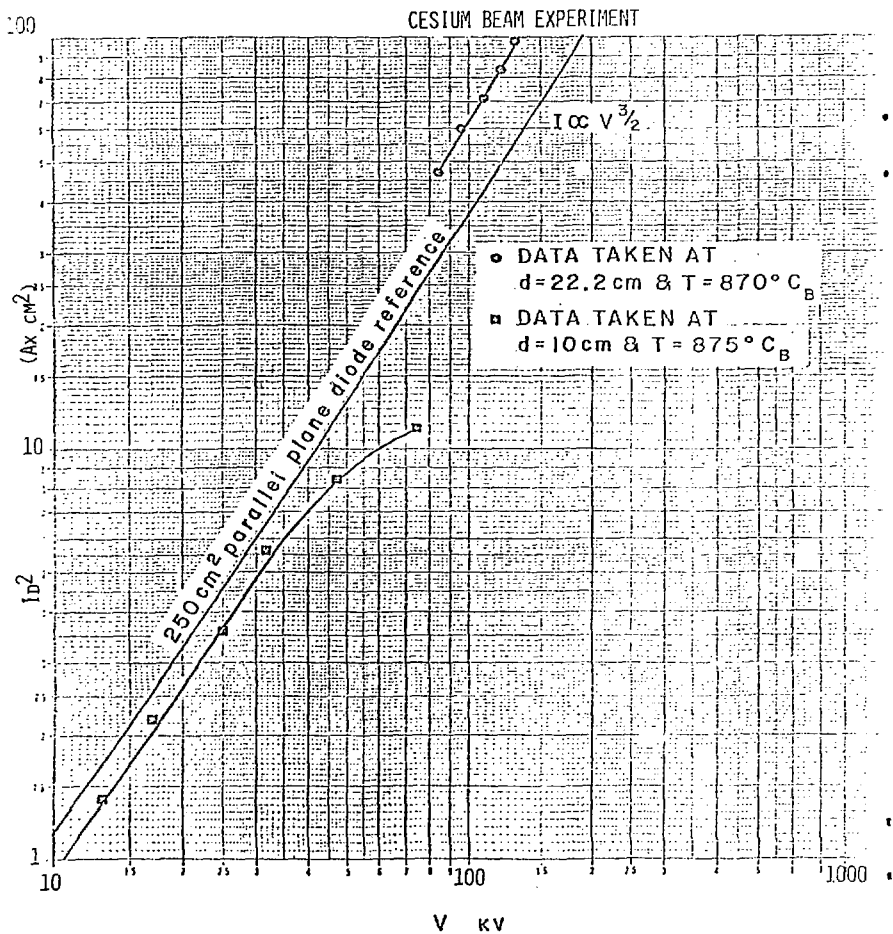

Figure 6

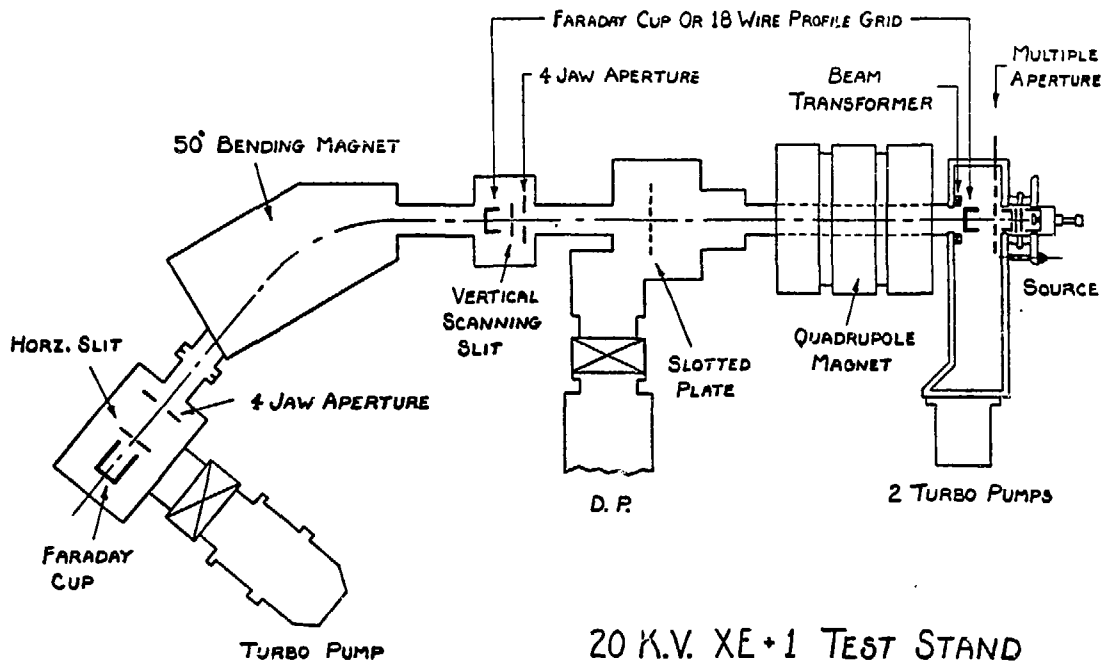

Figure 7

List of PublicationsHeavy Ion Fusion Notes - Report Index - October 1, 1977-March 31, 1978

HI-FAN-21 (LBL-6768)	A. Faltens, D. Judd, D. Keefe	Acceleration System for Heavy-Ion Beams for Inertial Confinement Fusion Second International Topical Conference on High Power Electron and Ion Beam Research & Technology (Cornell)	10/3/77
HI-FAN-22	L.J. Laslett	Examples of Instability Growth Rates	11/7/77
HI-FAN-23	L.J. Laslett	Matched Envelope Radii in FODO Transport Systems	11/10/77
HI-FAN-24	HIF Staff	Papers for Brookhaven HIF Workshop Proceedings, October 1977, which include the following:	10/77
	LBL-7221	Beam Bunching in a Final Storage Ring, Glen Lambertson	11/18/77
	LBL-7222	The "Figure of Merit", $Q/u_{\max}^{2/3}$, for Beam Transport Through Periodic Focusing Systems, L.J. Laslett	11/23/77
	LBL-7220	Production of Achromatic Spots With a Beam Transport System Consisting Only of Quadrupoles and/or Solenoids Klaus Halbach	11/23/77
	LBL-7144	Large-Aperture Pulsed 1-Ampere Cesium Source, W.W. Chupp, et al.	
	LBL-7143	Tests and Development of Duoplasmatron and Multi-Aperture Heavy Ion Sources for an RF Linac, D.J. Clark et al.	
		Summary--High Current Beam Transport, I. Hofmann	11/23/77
HI-FAN-25 (LBL-7267)	D. Judd	High-Energy Heavy-Ion Beams As Igniters For Commercial-Scale Inertial-Fusion Power Plants International Scientific Forum on an Acceptable Nuclear Energy Future of the World, November 7-11, 1977. (Coral Gables)	7/11/77
HI-FAN-26	D. Judd	Parametric Relations for Induction-Linac Accumulator-Ring Injectors	12/15/77
HI-FAN-27 (LBL-7200)	A. Faltens D. Keefe	Quasi-Static Drift-Tube Accelerating Structures for Low Speed Heavy Ions : Particle Accelerators (to be published)	11/17/77

List of Publications Continued.Heavy Ion Fusion Notes - Report Index - October 1, 1977-March 31, 1978

HI-FAN-28	A. Garren D. Neuffer	Final Transport and Focusing for HIDE	4/3/78
HI-FAN-29		Informal Quarterly Report on Heavy Ion Fusion Program Oct. 1 - Dec. 31, 1977	12/77
HI-FAN-30 (LBL-7519)	Denis Keefe	Overview of Heavy Ion Fusion Program in U.S.A. (IAEA Meeting, San Francisco)	2/2/78
HI-FAN-31	Denis Keefe	Copies of View-Graphs used in the following talks: The LBL Program in Heavy Ion Fusion - IEEE Conf. San Diego, Feb. 1978 Overview of Heavy Ion Fusion Fusion - IAEA Conf. San Francisco, Feb. 1978	2/78
HI-FAN-32 (LBL-7245)	D.L. Judd	Estimates of Post-Acceleration Longitudinal Bunch Compression	11/25/77